

# Research on the pricing and replenishment decision-making problem of vegetable products based on neural networks and grey wolf algorithm

Binchang Ma<sup>1</sup>, Yufan Deng<sup>2</sup>

<sup>1</sup>Department of Computer Science and Technology , Wuhan University of Science and Technology, Wuhan, China, 430065

<sup>2</sup>School of Management , Wuhan University of Science and Technology, Wuhan , China, 430065

\*Corresponding author: 15172599187@163.com

**Abstract.** This article deals with the knapsack problem, where, under real-world conditions, the wholesale prices for the day are not known, and the sales of vegetable products exhibit seasonal patterns. Therefore, this article utilizes an LSTM neural network model to predict the daily wholesale prices. Subsequently, the top 60 projects with the highest profits are selected to create a histogram, and available projects are chosen from these 60. Initially, this article identifies five factors that impact profit and transforms them into positive indicators. Weight allocation is done using the entropy weight method and fuzzy comprehensive evaluation method. The TOPSIS method is employed to obtain composite score indicators for the 60 projects. A linear programming objective function is established, and the results are solved using the Grey Wolf Optimization (GWO) algorithm.

**Keywords:** Neural Network, Optimization Model, Grey wolf Algorithm.

## 1. Introduction

With the increasing competition in the fresh produce market, reasonable pricing and replenishment strategies have become crucial factors for supermarket profitability. This article will focus on the pricing decisions and replenishment strategies for vegetable products, and analyze the relationship between vegetable sales and pricing. Taking into account various constraints such as the limitation of available SKU (Stock Keeping Unit) count, minimum display quantity, and seasonal patterns in vegetable category count and sales volume, this article constructs a planning model aiming to maximize profit and meet market demand as much as possible [1-2]. By providing guiding suggestions, it can avoid the occurrence of excessive inventory and stock situations, and better meet market demand. In practical applications, there are many similar scenarios to this problem. Therefore, this article aims to establish a more robust model. However, traditional forecasting methods such as grey forecasting and linear regression cannot achieve the objectives of this problem scenario due to the time lag effect of market demand and the instability of vegetable market data [3-7].

## 2. The basic fundamental of LSTM neural network

### 2.1. The structure of LSTM neural network

Long-Short Term Memory (LSTM) artificial neural network is an improved type of Recurrent Neural Network (RNN). LSTM can learn long and short-term dependencies in time series data. It is suitable for handling and predicting intervals and delayed events in time series data due to the presence of memory units in the neural network [8-10]. The specific process is shown in Figure 1.

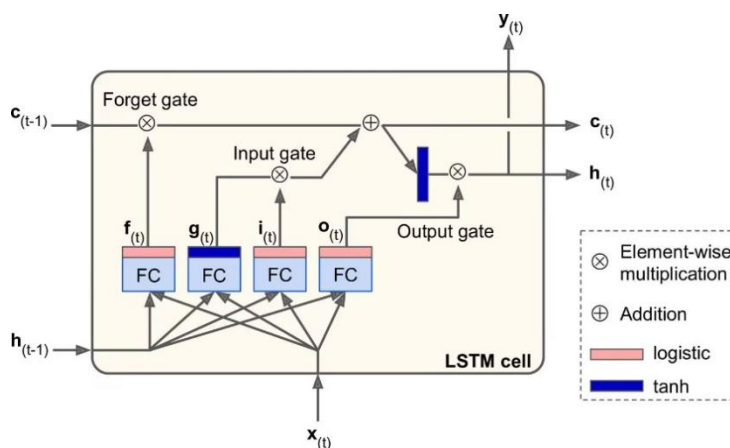

**Figure 1.** LSTM neural network structure

Using this method, predict the wholesale prices of various vegetable dishes for the day, then find four evaluation indicators and convert them into positive-type indicators, apply entropy weight method to calculate the weight of each indicator, and use it as the scoring basis for TOPSIS. The weights are shown in Table 1.

**Table.1.** Entropy weight method

Item	Information entropy value(e)	Information utility value(d)	Weight(%)
Average value item: sales unit price (RMB/kg)	0.918	0.082	14.483
Summation term: Sales (kg)	0.764	0.236	41.533
Count item: Scan sales time	0.752	0.248	43.751
Average value item: Wholesale price (yuan/kg)	0.999	0.001	0.233

## 2.2. TOPSIS Evaluation Method

TOPSIS evaluation method is an effective multi-criteria evaluation method that can fully utilize the information of the original data. Its results can accurately reflect the differences between various evaluation schemes. This method ranks the schemes by constructing the positive ideal solution and negative ideal solution of the evaluation problem, so as to select the optimal scheme.

$$D_i^+ = \sqrt{\sum_{j=1}^m \omega_j (Z_j^+ - z_{ij})^2} \tag{1}$$

Use the TOPSIS evaluation method to obtain the comprehensive score index of individual products and rank them. This article only shows the scores of the top twenty products. The specific scores are shown in Table 2. According to the available varieties in the previous week, derive the objective function of linear programming.

**Table.2.** Composite score indicator for individual items

Index	Positive ideal solution distance (D+)	Negative ideal distance (D-)	Comprehensive score index	Ranking
Wuhu Green Pepper (1)	0.359057914	0.924914376	0.720353845	1
Broccoli	0.365302663	0.842854976	0.697636591	2
Lotus root(1)	0.460451741	0.725712029	0.611814361	3
Xixia Mushroom(1)	0.534411754	0.53091379	0.498358265	4
Yunnan lettuce	0.534935462	0.526868371	0.496201233	5
Chinese cabbage	0.673471673	0.464387572	0.408123917	6
Eggplant(2)	0.630874454	0.408798988	0.393199414	7
Flammulina mushrooms(box)	0.696838304	0.389117039	0.358317717	8
Yunnan lettuce(serving)	0.716691457	0.357997119	0.333117079	9
Bubble pepper(Specialty)	0.691992488	0.331284271	0.323748457	10
Yunnan romaine vegetable	0.701483657	0.326485839	0.317602653	11
Abietia nigroderma	0.923428337	0.381499568	0.292352985	12
Screw pepper	0.733150553	0.284634327	0.279660597	13
Millet pepper(part)	0.777610217	0.272740281	0.25966597	14
Green stem scattered flowers	0.77573946	0.245647541	0.240503884	15
Shanghai blue	0.777103332	0.240297302	0.23618749	16
Black boletus	0.929147101	0.281512359	0.232528112	17
Yellow and White Vegetables(2)	0.78735689	0.233353367	0.228618617	18
Collybia albuminosa	0.930033257	0.274246549	0.227726603	19
Bamboo leaf	0.788475098	0.230886089	0.226500766	20

### 2.3. Replenishment Plan and Pricing Strategy

According to the available varieties in the previous week, derive the objective function of linear programming.

$$\text{Max}[R_1 - (1 + \beta) \times O] \times a \tag{2}$$

$$\text{s.t.} \begin{cases} 0 \leq a \leq M_{max}(1 - \beta) \\ 0 \leq \beta \leq 1 \\ M_{min} \geq 2.5 \\ l_1 = -1.57092x + 38.77714 \\ l_2 = -1.83096x + 44.31149 \\ \dots \\ l_{33} = -8.38943x + 56.48413 \end{cases} \tag{3}$$

$l$  is the linear regression equation obtained using the SVR algorithm for the total sales volume and cost markup pricing of each individual product.  $R_1$  is the selling price, and  $O$  is the cost predicted through time series (LSTM) forecasting.

Then, through the Grey Wolf Algorithm, the daily sales of all individual items and the purchase volume of each individual item are obtained, and finally the replenishment plan and pricing strategy for the individual items of the day are obtained. The results are shown in Table 3.

**Table.3.** Daily product replenishment plan and pricing strategy

Item	Profit(Yuan/kg)	Pricing(Yuan/kg)	Replenishment(kg)
Wuhu Green Pepper(1)	2.18	2.18	53.7
Broccoli	3.27	3.27	19.8
Lotus root(1)	2.29	2.29	20.4
Xixia Mushroom(1)	7.46	7.46	2.68
Yunnan lettuce	3.14	3.14	16.6
Chinese cabbage	0.83	0.83	17.5
Eggplant (2)	2.95	2.95	16.84
Flammulina mushrooms(box)	1.34	1.34	29.1
Yunnan lettuce(serving)	1.78	1.78	14.95
Yunnan romaine vegetable	2.70	2.7	10.75
Screw pepper	3.61	3.61	10.63
Millet pepper(part)	2.52	2.52	14.77
Shanghai blue	3.05	3.05	7.94
Yellow and white vegetables(2)	2.82	2.82	8.34
Bamboo leaf	1.96	1.96	7.56
Baby Chinese cabbage	1.76	1.76	16.28
Yunnan romaine vegetable(portion)	1.71	1.71	9.23
Screw pepper(part)	2.14	2.14	11.27
Milk cabbage	1.94	1.94	6.07
Spinach	3.70	3.7	5.44
Sweet potato tips	2.34	2.34	5.96
Flammulina mushrooms(1)	3.28	3.28	7.34
Red Pepper(1)	6.41	6.41	4.72
Amaranth	1.79	1.79	5.32
Flowering cabbage	2.86	2.86	4.59
crinkle(portion)	1.65	1.65	5.40
Sweet cabbage	3.11	3.11	4.89
Small Green vegetables(1)	2.43	2.43	3.41
Mushroom bisporus(box)	1.85	1.85	7.99
Green Eggplant(1)	2.45	2.45	3.53
Pleurotus eryngii(1)	10.11	10.11	3.36
Solanum japonicum	10.10	10.1	2.89
White mushroom(bag)	2.70	2.7	3.64

### 3. Results

#### 3.1. The establishment of simulation model

The maximum profit model for the supermarket has been implemented in MATLAB software.

#### 3.2. Analysis of experimental results

By comparing the actual data with the predicted results of today's vegetable menu items, we have found that the actual values are generally in line with the predicted values, although there is some margin of error, particularly during the months of March and April when there is a greater variety of agricultural products, as shown in Table 4.

Data sources used in the article:

[http://www.mcm.edu.cn/html\\_cn/node/c74d72127066f510a5723a94b5323a26.html](http://www.mcm.edu.cn/html_cn/node/c74d72127066f510a5723a94b5323a26.html)

**Table.4.** Comparison of Vegetable Menu Item Predictions

Item	Predicted values		Actual values	
	Pricing(Yuan/ kg)	Replenishment( kg)	Pricing(Yuan/ kg)	Replenishment( kg)
Wuhu Green Pepper(1)	2.18	53.7	2.22	53.9
Broccoli	3.27	19.8	3.30	20.1
Lotus root(1)	2.29	20.4	2.31	20.6
Xixia Mushroom(1)	7.46	2.68	7.51	2.72
Yunnan lettuce	3.14	16.6	3.11	15.8
Chinese cabbage	0.83	17.5	0.81	18.1
Eggplant (2)	2.95	16.84	2.91	16.88
Flammulina mushrooms(box)	1.34	29.1	1.35	29.0
Yunnan lettuce(serving)	1.78	14.95	1.81	14.9
Yunnan romaine vegetable	2.7	10.75	2.8	9.98
Screw pepper	3.61	10.63	3.68	9.87
Millet pepper(part)	2.52	14.77	2.58	14.52
Shanghai blue	3.05	7.94	3.41	6.98
Yellow and white vegetables(2)	2.82	8.34	2.98	8.23
Bamboo leaf	1.96	7.56	1.78	7.65
Baby Chinese cabbage	1.76	16.28	1.73	16.46
Yunnan romaine vegetable(portion)	1.71	9.23	1.87	9.18
Screw pepper(part)	2.14	11.27	2.71	10.89
Milk cabbage	1.94	6.07	2.2	5.85
Spinach	3.7	5.44	3.5	6.11
Sweet potato tips	2.34	5.96	2.45	5.86
Flammulina mushrooms(1)	3.28	7.34	3.28	7.34
Red Pepper(1)	6.41	4.72	5.76	4.93
Amaranth	1.79	5.32	1.71	5.44
Flowering cabbage	2.86	4.59	2.96	4.53
crinkle(portion)	1.65	5.40	1.72	5.22
Sweet cabbage	3.11	4.89	3.19	4.74

Small Green vegetables(1)	2.43	3.41	2.13	3.64
Mushroom bisporus(box)	1.85	7.99	1.63	8.21
Green Eggplant(1)	2.45	3.53	2.69	3.27
Pleurotus eryngii(1)	10.11	3.36	10.55	3.29
Solanum japonicum	10.1	2.89	9.97	3.12
White mushroom(bag )	2.7	3.64	2.96	3.43

From the comparison between predicted values and actual values, it can be observed that the LSTM model exhibits more accurate prediction performance, meeting the demand for maximizing profits in supermarkets. Additionally, it is characterized by simplified operations and enhanced process efficiency.

#### 4. Conclusions

Superstores have dense traffic flows, which provide a huge amount of data support for the prediction model, but traditional regression fitting and gray prediction methods cannot predict products with seasonal regular features such as vegetables. The characteristics of seasonal regularity will affect the prediction accuracy of data. This paper uses the LSTM neural network model to establish replenishment and pricing strategy models, and makes full use of MATLAB's data processing capabilities to make the prediction results more accurate. The LSTM neural network model has good predictability and universality, and can be extended to other fields.

#### References

- [1] Wang, Baojia , et al. "Research on Hybrid Model of Garlic Short-term Price Forecasting based on Big Data." *Computers, Materials and Continua* 57.2(2018):283-296.
- [2] Fan, Tijun , C. Xu , and F. Tao . "Dynamic pricing and replenishment policy for fresh produce." *Computers & Industrial Engineering* 139.Jan.(2020):106127.1-106127.14.
- [3] Indika, A. , Warusamana, N. , Welikala, E. , & Deegalla, S. . (2021). Ensemble stock market prediction using svm,lstm, and linear regression.
- [4] Xiong, Tao , C. Li , and Y. Bao . "Seasonal forecasting of agricultural commodity price using a hybrid STL and ELM method: Evidence from the vegetable market in China." *Neurocomputing* 275(2018):2831-2844.
- [5] Fang, Fei , T. D. Nguyen , and C. S. M. Currie . "Joint pricing and inventory decisions for substitutable and perishable products under demand uncertainty." *European Journal of Operational Research* 293.8(2018).
- [6] Feng, and Lin. "Dynamic pricing, quality investment, and replenishment model for perishable items." *International Transactions in Operational Research* (2019).
- [7] Yang, Yuqing , Y. Zhao , and S. Lai . "Temporal Convolutional Network for Pork Price Prediction." *ICBDM 2020: 2020 International Conference on Big Data in Management 2020*.
- [8] Zhang, Mingjie , et al. "Research and Application of Traffic Forecasting in Customer Service Center Based on ARIMA Model and LSTM Neural Network Model." *Journal of Physics: Conference Series* 1881.3(2021):032063-.

- [9] He Z , Yu S .Application of LightGBM and LSTM combined model in vegetable sales forecast[J].Journal of Physics: Conference Series, 2020, 1693(1):012110 (8pp).
- [10] Peng Hongxing et al. "Vegetable price prediction based on BP, LSTM and ARIMA models." Chinese Journal of Agricultural Mechanization 41.4 (2020): 7.