

A Design of Bare Printed Circuit Board Defect Detection System Based on YOLOv8

Zhijiang Xiong*

Department of Electronic and Information Engineering, Tiangong University, Tianjin, China

*2010910321@tiangong.edu.cn

Abstract. As electronic products develop towards miniaturization and digitization, printed circuit boards (PCBs) also develop towards high density and high precision. In the manufacturing process of PCBs, some PCBs with defects will be produced, and these defects often lead to circuit failure, so defect detection technology is an indispensable part of PCB manufacturing technology. Aiming at the problems of low efficiency and accuracy of traditional image recognition and classification technology, A PCB defect detection algorithm is proposed based on YOLOv8 in this paper. For these five PCB defects, the neural network in deep learning was used to identify and classify PCB defects. The prediction accuracy of YOLOv8 model after training is close to 97%, and it is compared with the accuracy of other algorithms to prove the effectiveness and feasibility of the model. In addition, the object detection image user interface is also established in this paper, which can realize image detection more conveniently.

Keywords: Bare PCB; YOLOv8; Defect detection; Deep learning; Object detection.

1. Introduction

A printed circuit board (PCB) consists of various electronic parts, which performs connections between electronic components [1]. PCB is an important component in the electronics industry, widely used in smart home appliances, health care, biosensors and other fields. As the support body of various electronic components and the carrier of electrical connection, it is extremely meaningful to ensure its stable quality. The quality detection of PCB has become the key step of quality control in the manufacturing process [2].

Traditional image processing methods have made many contributions to the development of object detection. Based on image processing methods, Z. Li et al. presented an automatic optical inspection system to complete object detection [3]. With the further development of related research, many scholars have obtained certain results by using the support vector machine (SVM) for PCB flaw detection. Thanasis Vafeiadis et al. proposed a classification using SVM with polynomial and radial basis kernel Functions, and successfully verified the effectiveness of the algorithm [4]. For automatic classification and recognition, Z. Zhang et al. optimized SVM classifier method and verified its feasibility [5].

However, SVM requires manual construction of features and a large amount of prior knowledge. In recent years, object detection techniques in deep learning have been widely used due to its effectiveness. Some scholars have obtained high accuracy in target detection through YOLO algorithm.

J. Li et al. optimized the YOLOv3 algorithm, and the high accuracy of their experiment proved the effectiveness of their model [6]. M. Glučina et al. trained a variety of YOLOv5 models with different structures at the same time and compared the results of these models to select the best network [7]. Based on YOLOX-WSC, B. Tuo et al. proposed a method for detecting PCB defect targets, which uses weakened data to enhance the inaccurate image introduced by Mosaic, completes the convergence in advance, and improves the model detection effect [8].

However, these algorithms have certain inaccuracies and limitations. Therefore, in view of the low efficiency and high cost of traditional manual and electronic defect detection methods in PCB production, a bare PCB defect detection system based on YOLOv8 algorithm is designed in this paper.

2. Methodology

2.1. Design of system architecture

The system architecture flow diagram is shown in Fig.1.

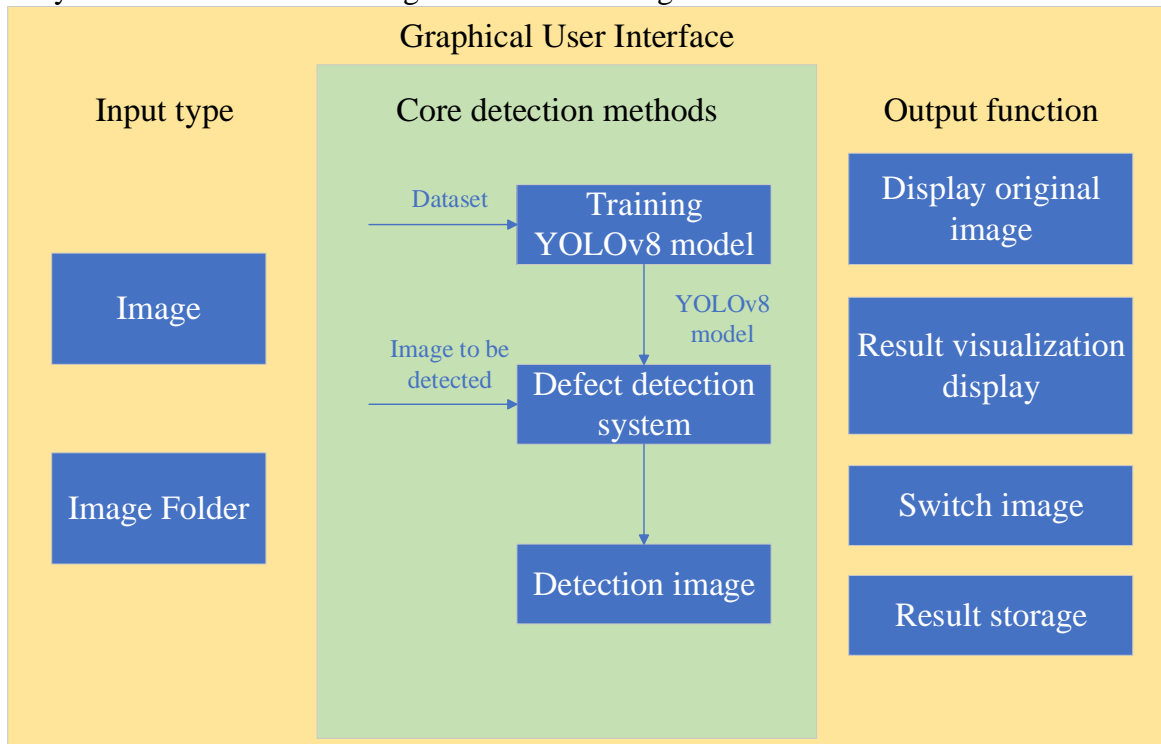

Fig. 1 System architecture flow diagram

In Graphical user interface, here are two types of import, image and image file, which are used to import PCB bare board images or folders containing multiple PCB bare board images. Images can contain multiple and different defects.

In core detection methods, first, based on the PCB bare board defect dataset, the YOLOv8 algorithm is used to train the YOLOv8 model. Then, in the defect detection system, the YOLOv8 model is loaded and the weight file is read. Finally, after the test image is imported, the defect detection is carried out to obtain the test image.

In output function, the output part has four functions: displaying the original image, detecting the visualization, switching the image and saving the image, which can realize the output of defect results. Display the original image is to display the image to be detected imported by the input part, detection visualization is to display the detection results, switch the image to display the previous or next detection results, and save the image to save the detection image results to the local library.

2.2. YOLOv8 target detection algorithm

YOLOv8 is a state-of-the-art and cutting-edge model. Compared with the previous YOLO series models, the YOLOv8 model has been added with improvements and innovations [9]. The basic framework and functions of YOLOv8 are shown in Fig.2.

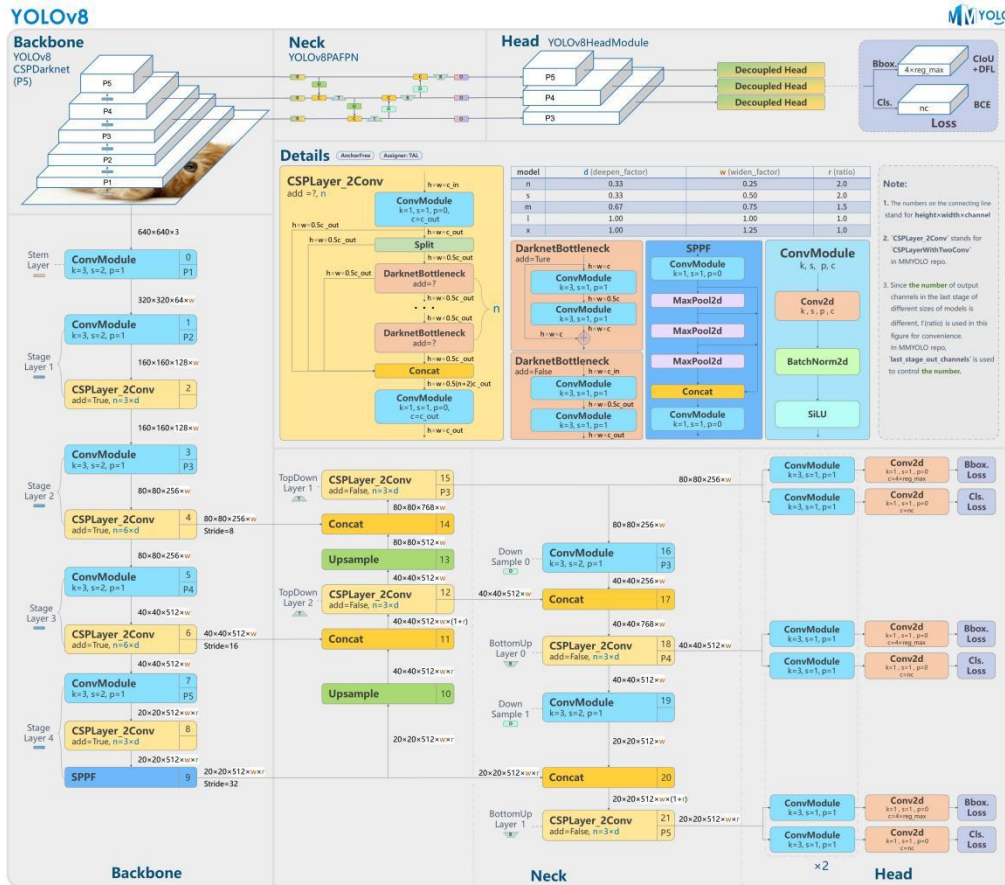

Fig. 2 The basic framework and functions of YOLOv8 [10]

The network structure of YOLOv8 consists of Input, Backbone, Neck and Head, which perform different functions. In the Input section, the input requirements and preprocessing are required. The backbone part is a backbone network. Compared with the YOLO model in the past, the updated part adopts two 3*3 convolution to reduce the resolution by four times, and substitute the c2f module for the c3 module, still using the SPPF module. The neck part is the detection head and matching mechanism, which turns the original coupling head into the decoupling head, and turns the Anchor-Based of YOLOv5 into Anchor-Free [11].

2.3. Construction of PCB defect detection system

The PCB defect inspection system designed in this paper is a software design, graphical user interface (GUI), which allows users to directly operate the graphical interface, including Windows, menus, buttons, toolbars and other graphical interface elements. The interface of PCB defect detection system in this paper is developed by Python, and the GUI interface is designed by CustomTkinter. Python comes with the tkinter module, which provides a convenient and quick way to build GUI applications. CustomTkinter is a python UI library based on Tkinter. The difference from Tkinter is that CustomTkinter provides new components for Tkinter.

3. Experiment

3.1. Experiment setting

This paper uses Google Colab to train the YOLOv8 model. By adjusting the number of epochs to be trained, the upper part of the model is trained. The dataset in this paper is derived from a synthetic PCB dataset published by Huang Weibo et al [12]. There were 578 images in the dataset, which contained 5 types of defects, namely, mouse bite, open circuit, short, spur and spurious copper. There

were three to five defects on each picture. Table 1 lists the number of defective pictures and the defect quantity information.

Table 1. Number of defective pictures and defect quantity information

Defect type	Number of pictures	Number of defects
mouse bite	115	492
open circuit	116	482
short	116	491
Spur	115	488
Spurious copper	116	503

Fig.3 shows the magnified images of various defects of PCB bare boards in the data set, where the framed part is the part with defects.

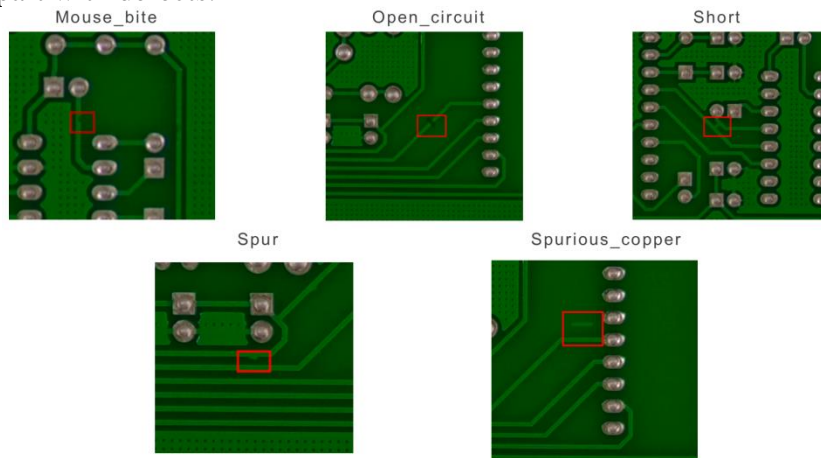

Fig. 3 Five types of PCB defects

In this paper, the mean Average Precision (mAP), Precision (P) and Recall (R) were used as evaluation indexes. The computational formulas are as follow:

$$\left\{ \begin{array}{l} P = \frac{TP}{TP+FP} \\ P = \frac{TP}{TP+FP} \\ AP = \int_0^1 P(r) dr \\ mAP = \frac{\sum_{i=0}^n AP(i)}{n} \end{array} \right. \quad (1)$$

Where TP means that the number of correctly classified as positive samples. FP means that the number of misclassified as positive samples. FN means that the number of misclassified negative samples. AP is the integral of the P-R curve, that is, the area enclosed by the curve and the coordinate system, and mAP is the average of the sum of aps of different categories.

3.2. Defect detection experiment based on YOLO-v8

The number of training epochs of the experiment is set to 80 in advance, and the ratio of the training set, test set, and validation set is set to 8:2:2.

After the training, the mAP value of the training part was 96.79%. The mAP value of the verification part was 96.34%. An example of the prediction in the validation section is shown in Fig.4. It can be seen that YOLOv8 can accurately identify and locate tiny PCB defects, and has good performance.



Fig. 4 Five types of PCB defects

3.3. Comparative experiment and analysis

To confirm the superiority of YOLOv8 algorithm in accuracy, this paper compared the algorithms and trained the same series of models YOLOv5 under the same experimental conditions. By comparing the AP values of each type of the two algorithms and the mAP value of the overall model, the accuracy of the YOLOv8 model is verified. Table 2 presents the final results of the experiments.

Table 2. Comparison between YOLOv8 accuracy and YOLOv5 accuracy

Model	Ap(%)					mAP (%)
	mouse bite	open circuit	short	spur	spurious copper	
Yolov5	0.894	0.865	0.883	0.912	0.891	0.889
Yolov8	0.962	0.973	0.995	0.964	0.955	0.968

A comprehensive comparison of the experimental results of the two algorithms shows that under the same experimental conditions, the AP values of the five types obtained by YOLOv8 model are much larger than those of YOLOv5 model, and the model accuracy is higher. Therefore, in general, YOLOv8 algorithm is the best classification scheme.

3.4. Graphical user interface

The interface functions are importing local images and identifying defect targets. The visual interface is established as shown in Fig.5.

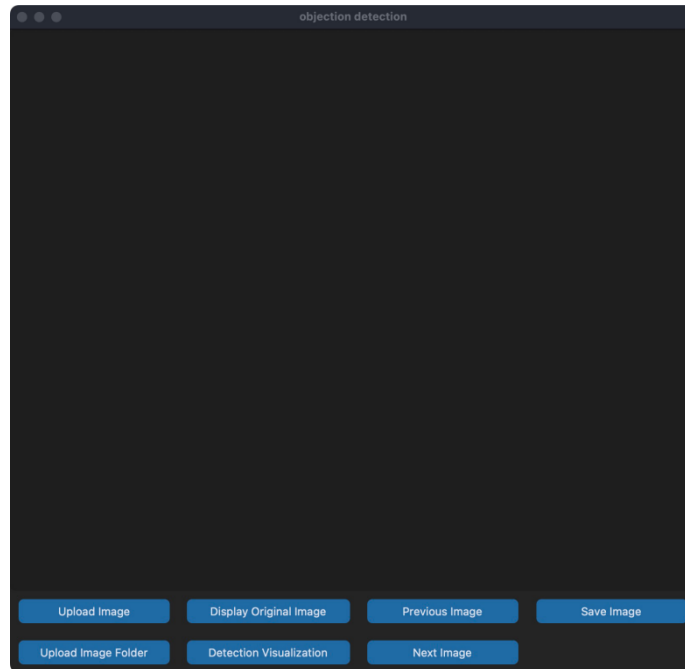

Fig. 5 Visual interface

At the beginning of detection, the program loads the previously trained YOLOv8 model, reads the pt model weights, and waits for the picture to be imported.

Click the "Upload Image" button to import the circuit image to be detected in the local library. Click the "Upload Image Folder" button to import the local circuit image folder to be detected. Click the "Display Original Image" button to display the imported picture on the interface. Click the "Detection Visualization" button to display the picture of defect detection results on the interface, mark the inferred defect with a box, and display the type of defect and its confidence level. Fig.6 shows an example of the detection results. Click the "Previous Image" and "Next Image" buttons to switch the display of pictures in order. Click the "Save Picture" button to save the test result picture to the local library.

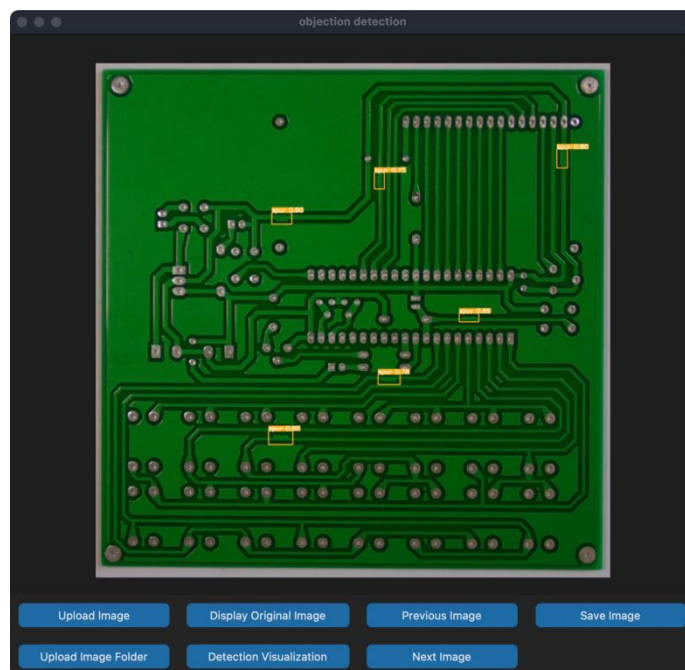

Fig. 6 The process of importing images

4. Conclusions

In this paper, a PCB defect detection system is constructed based on YOLOv8 algorithm, which can be used to detect defects on circuit boards containing a variety of defects. Based on the public PCB defect database, a YOLOv8 model is obtained by training. Observation of the training results shows that the model has excellent accuracy and performance, and the effectiveness of the model is further proved by comparing the accuracy with another model. The graphical user interface built in this paper has the characteristics of simplicity and convenience. Users can get accurate test results immediately after importing pictures or picture folders, and can realize basic functions such as saving to local. This system has complete and effective functions, and can be directly applied to PCB defect detection occasions.

References

- [1] Park, Joon-Hyung, et al. "Analysis of Training Deep Learning Models for PCB Defect Detection." *Sensors* 23.5 (2023): 2766.
- [2] Dai, Gang, et al. "PCB Defect Classification Model Based on Siamese Depth Feature Fusion Residual Network^①." *Computer Systems & Applications* (2023): 1-8.
- [3] Zheng-Ming, L. I., L. I. Hong, and J. Sun. "Detection of PCB based on digital image processing." *Instrum. Techn. Sens* 61.8 (2012): 87-89.
- [4] Vafeiadis, Thanasis, et al. "A framework for inspection of dies attachment on PCB utilizing machine learning techniques." *Journal of Management Analytics* 5.2 (2018): 81-94.
- [5] Zhang, Zhongqiu, et al. "An automatic recognition method for PCB visual defects." 2018 International Conference on Sensing, Diagnostics, Prognostics, and Control (SDPC). IEEE, 2018.
- [6] Li, Jing, et al. "Application research of improved YOLO V3 algorithm in PCB electronic component detection." *Applied Sciences* 9.18 (2019): 3750.
- [7] Glučina, Matko, et al. "Detection and Classification of Printed Circuit Boards Using YOLO Algorithm." *Electronics* 12.3 (2023): 667.
- [8] Tuo, Bing, et al. "Research on PCB Defect Detection Algorithm Based on YOLOX-WSC." *Computer Engineering and Applications* (2023):1-10.
- [9] "YOLOv8 Docs". Ultralytics, Mar. 2023. docs.ultralytics.com.
- [10] RangeKing. "Brief summary of YOLOv8 model structure". Github, 10 Jan. 2023. github.com/ultralytics/ultralytics/issues/189.
- [11] TigerZ. "Target detection algorithm -- YOLOV8 -- algorithm details". CSDN, 2 March. 2023.
- [12] Huang, Weibo, and Peng Wei. "A PCB dataset for defects detection and classification." arXiv preprint arXiv:1901.08204 (2019).