

Research and Evaluation of Electric Vehicle Charging Station Layout Planning Based on Greedy Algorithm

Chenyang Yu¹, Mingyan Chen^{2,*}, Haipeng Lu³, Zijing Yuan¹ and Ting Fang¹

¹ School of Automotive and Transportation Engineering, Wuhan University of Science and Technology, Wuhan, China

² School of Mechanical Automation, Wuhan University of Science and Technology, Wuhan, China

³ School of Computer Science and Technology, Wuhan University of Science and Technology, Wuhan, China

* Corresponding Author Email: 3013310614@qq.com

Abstract. Currently, the prospects for the development of electric vehicles are broad, and various technologies related to electric vehicles have become hot topics in domestic and international research. The layout of charging stations directly affects the promotion and application of new energy vehicles. In response to the problem of "more vehicles, fewer charging stations," this paper takes specific data from a city as an example, converts the problem into a simplified minimum spanning tree model to determine the routing algorithm, and uses a greedy algorithm to obtain a locally optimal solution to determine the optimal site selection plan with the fewest charging stations overall. At the same time, a multivariate linear programming model is established and solved using Lingo software to obtain the optimal construction plan for each charging station. A queuing algorithm is used to establish a mathematical model, and MATLAB software is used for simulation to simulate the queuing and operation situation of one charging station in a day, thereby we propose a solution to the current problem of uneven spatial distribution and low utilization of new energy vehicle charging stations.

Keywords: Electric vehicle charging station; Minimum spanning tree; Greedy algorithm; Multivariate linear programming; Queueing algorithm.

1. Introduction

With the advancement of technology, the usage rate of new energy vehicles is continuously growing. This situation poses higher requirements for the construction of charging and swapping infrastructure. To address the issues of insufficient distribution and low utilization of charging stations, it is essential to propose spatial layout optimization strategies for charging station planning to maximize the efficiency and utilization of charging facilities.

Regarding the problem, Chen Fangyu et al. ^[1] proposed a weighted calculation model through the Analytic Hierarchy Process (AHP) model. He Shu et al. ^[2] integrated various factors and built an objective programming model with the minimum social cost. Xie Yuande et al. ^[3] constructed a charging station distribution model based on Voronoi diagrams to achieve layout planning. Hu Ran et al. ^[4] used the grey-ideal correlation entropy method to study the rational planning and site selection of charging stations. Song Qiang et al. ^[5] established an economic model for new energy vehicle charging stations. Zhao Zheyuan et al. ^[6] proposed an optimization method for the layout of new energy vehicle charging stations based on fuzzy decision-making algorithms, among others. Research on the spatial distribution optimization of charging stations for new energy vehicles has been continuously deepened. However, there are still some shortcomings.

This paper proposes to simplify the minimum spanning tree model and determine the routing algorithm by straightening the curves. The greedy strategy is used to obtain a locally optimal solution, thereby determining the overall optimal solution. Additionally, a multivariate linear programming approach is utilized to determine the optimal construction plan for charging stations. A queueing algorithm model is employed to address the potential issue of electric vehicles queuing for charging due to insufficient charging stations in practice. This research aims to improve the uneven spatial

distribution and low utilization of new energy vehicle charging stations. MATLAB, Lingo, and other software are used for solving, and the optimal construction plan is obtained.

2. Greedy Algorithm

2.1. Problem Description

2.1.1 Model Assumptions

During the modeling process, the following assumptions are made:

1. The average driving speed of electric vehicles in the city is 32 kilometers per hour.
2. Electric vehicles prioritize charging at the nearest charging station, and each charging session fills the battery to 80% of its capacity.
3. Each charging station is located at a node within a residential area.
4. All charging stations are fully functional, and the charging efficiency of all charging ports is the same.
5. The demand for electric vehicle charging at each charging station follows a Poisson distribution, and charging services are provided on a first-come, first-served basis.
6. All electric vehicles within the coverage area of each charging station can reach the charging station within 3-5 minutes.

2.1.2 Model Constraints

1. The total cost of a charging station is the sum of the costs of all substations and charging ports within that station.
2. The energy provided by a charging station must meet or exceed the energy demand of all vehicles within its coverage area.
3. Each vehicle charges with an amount equal to 80% of its battery capacity during each charging session.
4. The proportion of a specific type of charging port within a substation must not exceed 60%.
5. Sufficient charging ports must be available at a station to accommodate all vehicles arriving within its coverage area simultaneously.
6. Charging ports can only be installed within substations.
7. The total load of substations must be greater than or equal to the total load of charging ports within those substations.
8. The number of vehicles should be represented as integers.

These constraints are incorporated into the model to ensure that the charging station layout plan meets operational requirements and is feasible within the given constraints.

2.1.3 Optimization Objectives

1. Minimize the number of charging stations required for the overall planning.
2. Minimize the total cost of constructing the charging ports.

2.2. Minimum Spanning Tree Model

In order to ensure that electric vehicles can reach the charging stations within 3-5 minutes from any given neighborhood, the distance between the electric vehicles and the charging stations must be less than the maximum distance the vehicles can travel. Since cars travel along roads, it is not appropriate to consider a circular area with a radius equal to the maximum distance the vehicles can travel from a specific node when discussing nodes that can be reached within 3-5 minutes. Instead, a path consisting of line segments based on the road network should be considered for the travel between two nodes.

In order to simplify the road connections between the nodes in each district, the Prim method from the minimum spanning tree can be used, and the city's transportation routes can be transformed accordingly. The specific process is shown in Figure 1.

- Step 1: Select any point from set U and add it to set V (where set U represents the vertex set of graph G).
- Step 2: Check if U-V is an empty set. If not, proceed to Step 3. If it is empty, go to Step 5.
- Step 3: Calculate the weight between any point in U-V and any point in set V.
- Step 4: Select the point x with the minimum weight, add it to set V, and go back to Step 2.
- Step 5: Connect the nodes in set V according to their order to obtain the minimum spanning tree of graph G.

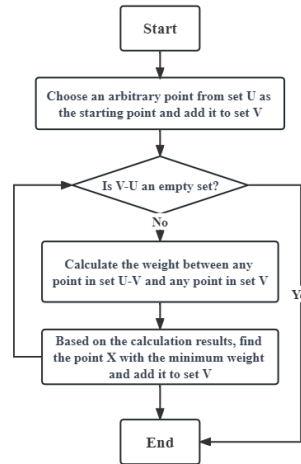

Fig. 1 Algorithm flow of minimum spanning tree model

2.3. Multivariate linear programming model

The total cost of a charging station is the sum of the costs of all substations and charging piles in each charging station. Therefore, the objective function can be derived as follows:

$$W_i = \min \left(\sum_{j=1}^3 P_j \cdot x_{ij} + \sum_{j=1}^3 \sum_{k=1}^4 P_{jk} \cdot x_{ijk} \right) \quad (1)$$

In the equation: x_{ij} is the number of substations D_j ($j=1, \dots, 8$) in the i -th group ($i=1, \dots, 8$) of charging stations. x_{ijk} is the number of charging piles Q_k ($k=1, 2, 3, 4$) in the situation. P_j ($j=1, 2, 3$) is the price of substation D_j . P_{jk} ($j=1, 2, 3; k=1, 2, 3, 4$) is the unit price of charging pile Q_k in substation D_j . W_i ($i=1, \dots, 8$) is the minimum construction cost of the i -th group of charging stations.

Since each charging session charges 80% of the battery capacity, which is 80% of the demand, we obtain the constraint condition 1 as follows:

$$80\% (E_A \cdot N_{iA} + E_B \cdot N_{iB} + E_C \cdot N_{iC}) \leq \sum_{j=1}^3 E_j \cdot x_{ij} \quad (2)$$

In the equation: N_{iA} , N_{iB} , N_{iC} ($i=1, \dots, 8$) are the number of Class A, Class B, and Class C electric vehicles within the coverage of the i -th group of charging stations, respectively. E_A , E_B , E_C represent the battery capacity of Class A, Class B, and Class C electric vehicles, respectively. E_j ($j=1, 2, 3$) represents the battery capacity of substation D_j .

It is known that the proportion of the same type of charging piles within a substation should not exceed 60%. This can be extended to all substations, where the proportion of the same type of charging piles within all substations should not exceed 60%. Therefore, we obtain constraint condition 2 as follows:

$$60\% \cdot \sum_{k=1}^4 x_{ijk} \geq x_{ijk} \quad (j=1, 2, 3) \quad (3)$$

Without considering queuing situations, under extreme conditions where all cars within a station's range arrive simultaneously, there should be an adequate number of charging stations to accommodate them. Therefore, the number of charging stations should not be less than the number of cars. This leads to constraint condition 3:

$$\begin{cases} N_{iA} \leq \sum_{j=1}^3 x_{ij3} + \sum_{j=1}^3 x_{ij4} = \sum_{k=3}^4 \sum_{j=1}^3 x_{ijk} \\ N_{iB} \leq \sum_{j=1}^3 x_{ij2} + \sum_{j=1}^3 x_{ij3} = \sum_{k=2}^3 \sum_{j=1}^3 x_{ijk} \\ N_{iC} \leq \sum_{j=1}^3 x_{ij1} + \sum_{j=1}^3 x_{ij2} = \sum_{k=1}^2 \sum_{j=1}^3 x_{ijk} \\ N_{iC} + N_{iB} + N_{iA} \leq \sum_{k=1}^4 \sum_{j=1}^3 x_{ijk} \end{cases} \quad (4)$$

Charging stations can only be installed within substations. Therefore, constraint condition 4 can be formulated as follows:

$$x_{ij} \leq \sum_{k=1}^4 x_{ijk} \quad (j = 1,2,3) \quad (5)$$

The total load of substations must be greater than or equal to the total load of charging stations. Therefore, we can formulate constraint condition 5 as follows:

$$E_i \cdot x_{ij} \geq \sum_{k=1}^4 Q_k \cdot x_{ijk} \quad (j = 1,2,3) \quad (6)$$

In general, cars cannot be divided, and the quantity should be an integer. Therefore, x_{ij} and x_{ijk} are natural numbers. That is:

$$x_{ij}, x_{ijk} \in N \quad (7)$$

3. Solution of the Charging Facility Optimization Model

The traffic route map of a certain city is shown in Figure 2. By using the Prim's algorithm from the Minimum Spanning Tree, we implemented a Java software program to convert the original graph into a minimal connected subgraph with 52 nodes. This new generated graph not only includes all 52 nodes from the original graph but also retains the minimum number of edges for a connected graph, as shown in Figure 3.

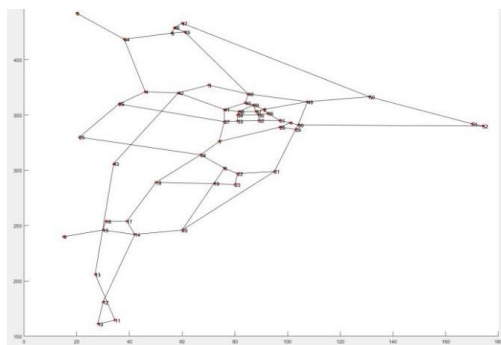

Fig. 2 Citywide Traffic Map

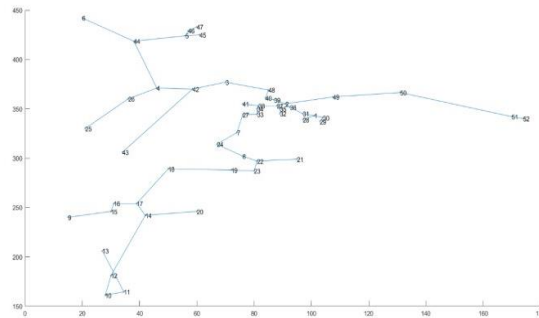

Fig. 3 Minimum spanning tree image

Figure 3 represents a two-dimensional transportation graph with the minimum number of edges, indicating the smallest number of paths. To make the visualization more intuitive, nodes 3 and 13,

which are relatively distant, are chosen as the endpoints to create a cross-shaped transportation road map, as shown in Figure 4.

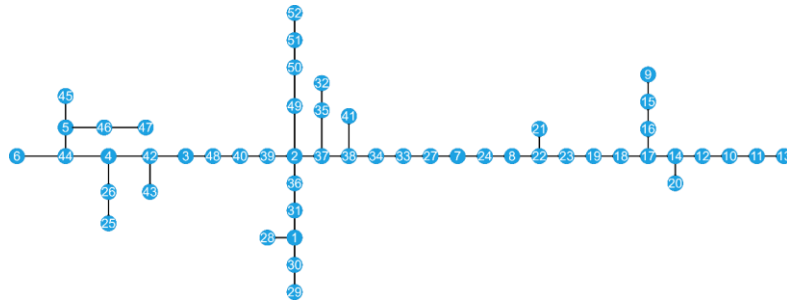

Fig. 4 Minimum spanning tree for cross-shaped traffic routes

3.1. The Minimum Number of Charging Stations Required for the Overall Planning

To determine the minimum number of charging stations, this study will employ a greedy algorithm to solve the charging station allocation problem. The greedy algorithm progresses towards the global optimum by consistently selecting local optima.

Firstly, an arbitrary node is selected as the starting node to establish a charging station. At this point, the constraint of the submodel is that the distance from other nodes to the starting node must be less than the maximum distance a car can travel. The objective function is to maximize the number of nodes, resulting in the optimal solution for the starting node. Without considering the other points included in the range of the previous central node, another node is selected as the central node in the order of the nodes. A similar submodel is established to find the set of nodes within the range of this central node.

Table. 1 Siting plan for the charging station and the nodes included.

Charging station	Location	Included nodes
1	44	5, 6, 45, 46, 47
2	4	3, 25, 26, 42
3	43	3, 25, 26, 42
4	51	3, 25, 26, 42
5	38	1, 2, 7, 27, 28, 29, 30, 31, 32, 33, 34, 35, 36, 37, 39, 40, 41, 48, 49
6	19	8, 18, 21, 22, 23, 24
7	14	9, 15, 16, 17, 20
8	11	10, 12, 13

To ensure local optimality, we take the 52 nodes given in the problem one by one as the starting node and calculates the location options for all 52 cases. By comparing the results, the optimal solution that is both locally and globally optimal is determined, as shown in Table 1.

Based on the data in Table 1 and combining it with the crossroad route map shown in Figure 4, we can obtain the route map of the optimal site selection solution, as shown in Figure 5.

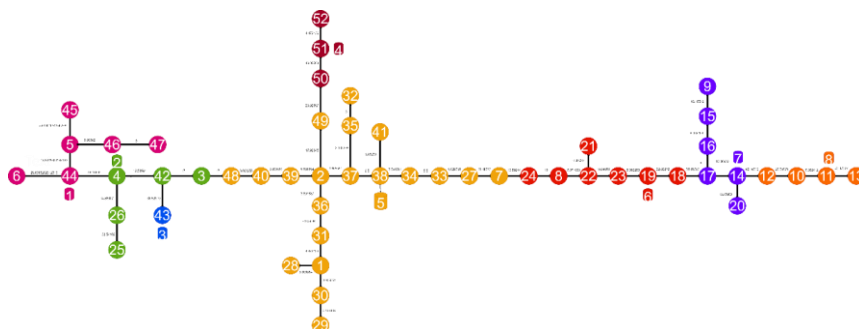

Fig. 5 Optimal solutions for transport routes

The site selection solution with the minimum number of charging stations, where electric vehicles from any neighborhood can reach a charging station within 3 minutes, is as follows: Charging stations are established at nodes 44, 4, 43, 51, 38, 19, 14, and 11.

3.2. The Minimum Cost of Constructing and Operating the Charging Stations

The types of substations are categorized into three categories, as shown in Table 2, with specific data. The charging stations are specified to have four types of models, as shown in Table 3. The electric vehicles are categorized into three types, with detailed specifications provided in Table 4.

Table. 2 Substation parameters

Type	Capacity (KW)	Price (yuan)
D1	1500	72000
D2	1080	53000
D3	650	33000

Table. 3 Charging Pillar Parameters

Type	Maximum power (KW)	Price (yuan)
Q1	110	11000
Q2	75	6000
Q3	50	3200
Q4	30	1700

Table. 4 Electric Vehicle Parameter

Type	Rated charging power (KW)	Compatible Charging Pillar	Battery capacity (KW)
A	30	Q4、Q3	38
B	50	Q3、Q2	65
C	75	Q2、Q1	90

By optimizing the objective of minimizing costs and using the multi-variable linear programming model in the Lingo software programming, we can obtain the optimal solutions for each group of substation construction plans. By combining these solutions, we can determine the optimal strategy for the overall construction of charging facilities in the city. The decision results obtained from the calculations are shown in the following table:

Table. 5 Four charging pile construction strategies for different substations

Charging Station	D1				D2				D3			
	Q1	Q2	Q3	Q4	Q1	Q2	Q3	Q4	Q1	Q2	Q3	Q4
1	0	53	137	285	0	54	0	81	0	0	2	3
2	0	132	82	321	0	0	0	0	0	0	6	9
3	0	0	0	0	0	16	24	60	0	0	0	0
4	0	53	83	202	0	0	0	0	0	0	0	0
5	0	420	367	1180	0	0	23	34	0	0	1	1
6	0	161	137	447	0	0	1	1	0	0	13	19
7	0	100	140	357	0	0	0	0	0	1	0	1
8	0	102	88	285	0	0	2	3	0	10	0	15

Table. 6 Construction strategies for the three types of substations at each charging station

Charging Station	D1	D2	D3	Cost of substations and charging stations
1	13	7	1	3054100
2	17	0	1	2391600
3	0	4	0	486800
4	10	0	0	1647000
5	57	8	1	10397700
6	22	1	2	3946100
7	18	0	1	2991600
8	14	1	2	2602100

Taking the first group as an example, as indicated in the table, the optimal strategy for the first group is to construct 13 substations D1, with 0 charging stations Q1, 53 charging stations Q2, 137 charging stations Q3, and 285 charging stations Q4. Additionally, 7 substations D2 should be constructed, with 0 charging stations Q1, 54 charging stations Q2, 0 charging stations Q3, and 81 charging stations Q4. Lastly, 7 substations D3 should be constructed, with 0 charging stations Q1, 0 charging stations Q2, 2 charging stations Q3, and 3 charging stations Q4.

By following the strategies outlined in the table, the total cost of construction is 27,517,000 yuan.

4. Evaluation of Charging Station Layout based on Queuing Theory

4.1. Queuing Model

In practical operations, due to the randomness of customer arrivals and service times, queuing may occur during the charging process of electric vehicles. Therefore, it is crucial to determine the minimum number of charging stations that satisfy the conditions.

The three elements of queuing theory are: customer arrival process, queuing structure, and service discipline. The characteristics of each element in this model are summarized in Table 7.

Table. 7 Features of the three elements of queuing theory

Customer Arrival Process	Customers are finite in number, and their arrivals are mutually independent and serve at the charging station one by one. The arrival intervals are random.
Queuing Structure	The number of queues is multiple, and once customers join a queue, they cannot switch or leave midway. The system capacity is unlimited.
Service Discipline	There are multiple service counters that operate in parallel, and each counter serves customers one by one. The service time is predetermined.

According to the general principle, charging services should follow the "first-come, first-served" rule, which forms an M / M / c queuing system. The queuing system structure for the charging station customers is illustrated in Figure 6.

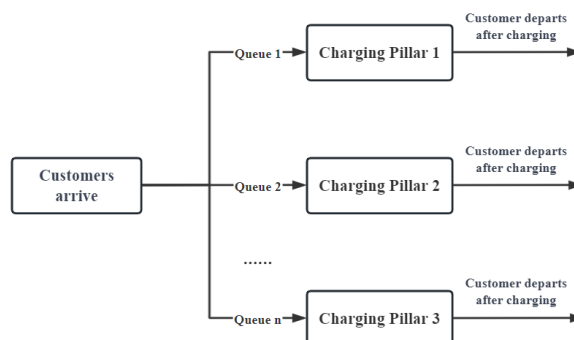

Fig. 6 Multi-Service Desk Queuing System Diagram

Assuming that the number of electric vehicles arriving at the charging station follows a Poisson distribution with a parameter λ , we can consider the random variable x to represent the number of customers arriving per unit of time. This random variable x satisfies the Poisson distribution, which can be expressed as $X = P(\lambda)$. The probability distribution can be expressed as:

$$P(x = k) = \frac{\lambda^k}{k!} e^{-\lambda} \quad (8)$$

The arrival intervals between customers and the service times both follow exponential distributions. Let T be a random variable representing the inter-arrival time between consecutive customers. It satisfies the following relationship:

$$T \sim f(t) = \mu_1 e^{-\mu_1 t} \quad (9)$$

The random variable V , representing the inter-departure time between consecutive customers, also follows an exponential distribution. It can be expressed as:

$$V \sim f(t) = \mu_2 e^{-\mu_2 t} \quad (10)$$

Where u_1 and u_2 are independent, uniformly distributed random variables on the interval $(0, 1)$.

Based on the analysis of electric vehicle charging behavior and the fundamental principles of queuing theory, the steady-state equations for the electric vehicle charging system can be derived from the state transition relationships. It could be formulated as:

$$\begin{cases} \lambda P_0 = \mu P_1 \\ \lambda P_{n-1} + (n+1)\mu P_{n+1} = (\lambda + n\mu)P_n \\ \lambda P_{n-1} + c\mu P_{n+1} = (\lambda + c\mu)P_n \end{cases} \quad (11)$$

In the equation: P_n represents the probability that an electric vehicle can receive charging service. c represents the number of charging devices available for charging service at the charging station. n represents the number of electric vehicles receiving charging service. When $0 \leq n \leq c$, it indicates that there are n electric vehicles receiving charging service at the charging station, and the remaining $c-n$ charging devices are in idle state. When $n > c$, it indicates that all c charging devices at the charging station are busy, and the remaining $n-c$ electric vehicles are queuing for charging.

By using the recursive method to solve the difference equation of the given equation, we obtain the probability of vehicles receiving charging at the charging station as follows:

$$P_0 = \left[\sum_{k=0}^{c-1} \frac{1}{k!} \left(\frac{\lambda}{\mu}\right)^k + \frac{1}{c!} \cdot \frac{1}{1-\rho} \cdot \left(\frac{\lambda}{\mu}\right)^c \right]^{-1} \quad (12)$$

Assuming ρ represents the utilization rate of the charging station facilities, its formula is given by:

$$\rho = \frac{\lambda}{c\mu} \quad (13)$$

When $\rho \leq 1$, there won't be an infinite queue. The average arrival rate at the charging station equals the departure rate, reaching an equilibrium state. When $\rho > 1$, queueing phenomenon occurs, and customers start queuing and waiting.

Through the calculations mentioned above, we can obtain the main performance measures of the queueing model:

Average number of customers in the queue:

$$l_q = \frac{(c\rho)c\rho}{c!(1-\rho)} P_0 \quad (14)$$

Average number of customers in the system:

$$l = l_q + \frac{\lambda}{\mu} \quad (15)$$

Average waiting time:

$$W_q = \frac{l_q}{\lambda} \tag{16}$$

Average stay time:

$$W = \frac{1}{\lambda} = W_q + \frac{1}{\mu} \tag{17}$$

4.2. Simulation of Charging Station Operation

Based on the established queuing model described above, this paper will select the neighborhood with the index number 43 and use the queuing algorithm for model solving to obtain the operational situation of the charging station throughout the day and perform simulation.

Based on the given data, it is known that the neighborhood with index number 43 has 56 A-grade electric vehicles, 28 B-grade electric vehicles, and 16 C-grade electric vehicles, totaling 100 vehicles.

The electric vehicle charging station is closely related to people's daily life activities. According to statistical data from gas stations, about 40% of refueling activities occur between 16:00 and 20:00. After electric vehicles arrive at the charging station, they seek available charging facilities for service. Drawing on statistical methods and charging behavior patterns from gas stations, the following parameters can be derived: Assuming that the 100 vehicles need to charge at the station between 4:00 and 24:00, we can calculate the average number of charging vehicles per hour as 5 vehicles. From this, we can determine the parameter for the Poisson distribution as: $\lambda = 5$.

Table. 8 Number of charging posts set (without considering queuing)

X_{32}	X_{321}	X_{322}	X_{323}	X_{324}
4	0	16	24	60

The calculation results indicate that when the number of charging piles is 100 (as in the above scenario), the average number of vehicles waiting in the queue is 0.

Remove the constraint of queuing and redefine the objective function as follows:

$$W_i = \min\left(\sum_{j=1}^3 P_j \cdot x_{ij} + \sum_{j=1}^3 \sum_{k=1}^4 P_{jk} \cdot x_{ijk}\right)$$

Reestablish the constraints:

$$\left\{ \begin{array}{l} 80\% (E_A \cdot N_{iA} + E_B \cdot N_{iB} + E_C \cdot N_{iC}) \leq \sum_{j=1}^3 E_j \cdot x_{ij} \\ 60\% \cdot \sum_{k=1}^4 x_{ijk} \geq x_{ijk} (j=1,2,3) \\ x_{ij} \leq \sum_{k=1}^4 x_{ijk} (j=1,2,3) \\ E_i \cdot x_{ij} \geq \sum_{k=1}^4 Q_k \cdot x_{ijk} (j=1,2,3) \\ x_{ij}, x_{ijk} \in N \end{array} \right.$$

Based on the above model, this study sets the number of charging piles to be 4, 8, and 16, respectively, and verifies the rationality of the number of charging piles through the aforementioned model. The results show that all three cases satisfy the constraint conditions. Based on this, queuing simulation will be conducted.

Table. 9 Number of charging posts set

X_{32}	X_{321}	X_{322}	X_{323}	X_{324}	Total Number
4	0	1	1	2	4
4	0	2	2	4	8
4	0	4	4	8	16

According to the calculations, when there are 4 or 8 charging piles. The significance of the queuing situation for electric vehicle charging is average, which can also indicate that the queuing model established in this situation is relatively successful and can accurately predict the daily operation of the charging station. With 16 charging piles, the queuing situation of electric vehicle charging is not obvious, because the Charging station is built too much, so it can be charged directly without queuing. The queuing model under the above three conditions can accurately restore the daily operation of the charging station at different Charging station.

The simulation results and corresponding graphs for the three scenarios with 4, 8, and 16 charging piles are as follows.

Table. 10 Dynamic simulation results

Number of Charging Piles	Average number of vehicles waiting	Average number of vehicles in the system	Average waiting time	Average stay time
4	0.21664239	2.30923414	1.55982583	16.62649248
8	1.55982583	1.05444633	0.00001662	7.59201662
16	0	0.52722201	0	3.796
72	0	0.11716045	0.84355556	0
100	0	0.08435552	0.60736	0

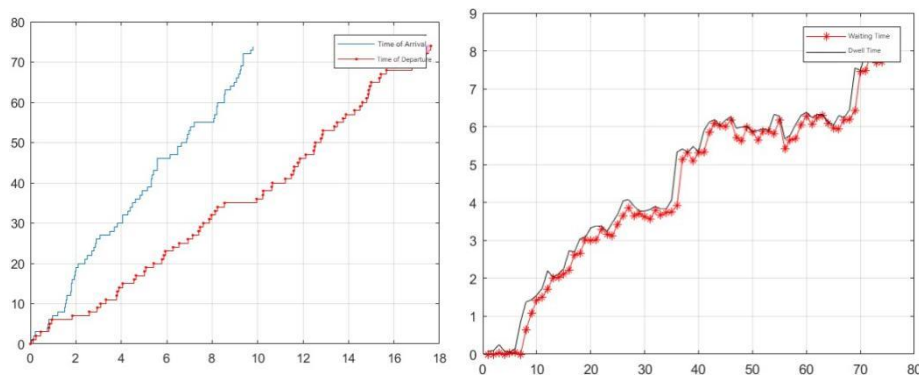

Fig.7 Simulation graph with number of charging piles as 4

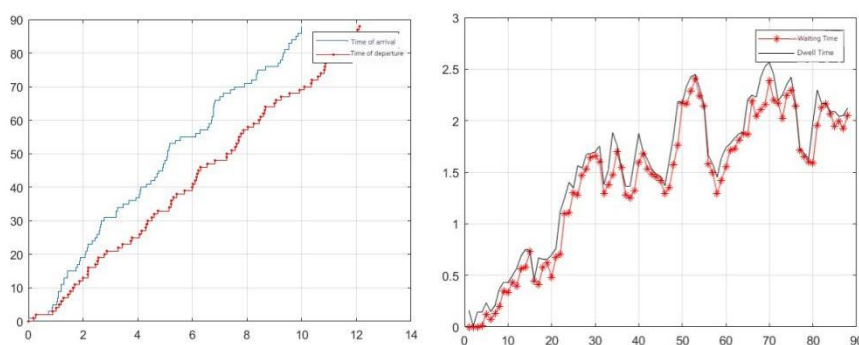

Fig. 8 The number of charging piles is 8 simulation curves.

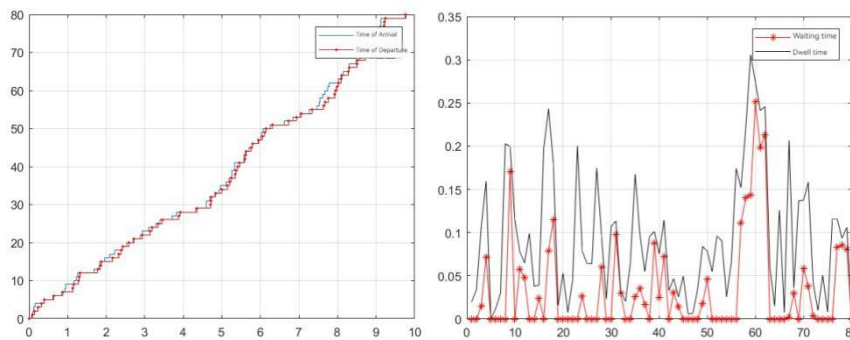

Fig. 9 Simulation graph with number of charging piles as 8

5. Summary

This paper has established minimum spanning tree and multiple linear programming models based on optimization algorithms, aiming to minimize electric vehicle travel time, minimize the number of cities charging stations for site selection, and minimize the cost of charging station construction and operation. Factors such as geographical information were taken into account, and simulation analysis was conducted on specific cases. Through detailed calculations and comparisons, the optimal solutions were obtained. Additionally, a queuing algorithm model was established to simulate and analyze the operational conditions of a specific residential area charging station throughout the day, demonstrating the accuracy of the model and calculations.

However, the cost of building charging piles is relatively high due to the assumptions made in the model. In future research, it is suggested to sacrifice the waiting time for charging users to further reduce the number of charging piles and thus reduce construction costs, aiming to maximize economic benefits.

References

- [1] Chen Fangyu, Wu Shuangpin, Jiang Huixian, et al. Research on the Optimization of Spatial Layout for New Energy Vehicle Charging Stations [J]. *Fujian Computer*, 2019, 35(9): 19-24. DOI: 10.16707/j.cnki.fjpc.2019.09.005.
- [2] He Shu. Research on the Optimization of Layout for Public Charging Stations of New Energy Vehicles [D]. Guangdong: South China University of Technology, 2019.
- [3] Xie Yuande, Zhang Lin, Deng Shali, et al. Research on the Optimization of Network Layout for Electric Vehicle Charging Facilities [J]. *Practice and Understanding of Mathematics*, 2020, 50(10): 168-176.
- [4] Hu Ran, Dong Xiaoyu, Wei Huxiaoya, et al. Site Selection Analysis of New Energy Vehicle Charging Stations in Lhasa [J]. *Science and Informatization*, 2020(14): 111.
- [5] Song Qiang. Research on the Optimization of Spatial Layout for New Energy Vehicle Charging Stations [J]. *Science and Informatization*, 2020(6): 124.
- [6] Zhao Zheyuan, Yang Hongwei, Liu Bing, et al. Optimization Method for the Layout of New Energy Vehicle Charging Stations Based on Fuzzy Decision Algorithm. *Henan Science*, 2022, 40(11): 1721-1727. DOI: 10.3969/j.issn.1004-3918.2022.11.001.