

Simulation Of Single-Phase Half-Wave Rectifier Circuit Based on Wind Energy Storage Circuit

Ruichen Xu *

Department of mechanical engineering, University of Shanghai for Science and Technology,
Shanghai, 200093, China

* Corresponding Author Email: 2014070122@st.usst.edu.cn

Abstract. Wind energy storage has broad application prospects in renewable energy. In view of many problems in the conversion and transmission of electric energy in wind energy storage system, research and simulation based on single-phase half-wave rectifier circuit can effectively solve these problems. This paper introduces the simulation study of a single-phase half-wave rectifier circuit based on wind energy storage circuit. Firstly, the principle and basic composition of wind energy storage system, as well as the working principle and circuit composition of single-phase half-wave rectifier circuit are introduced from the theoretical aspect. Subsequently, the simulation tool Multisim was used to establish a model of single-phase half-wave rectifier circuit and simulated it. Through simulation research, it can be found that the single-phase half-wave rectifier circuit has the advantages of high conversion efficiency, simple structure and low cost. In practice, the capacitor size in the circuit can be increased to optimize the efficiency of the circuit. In the future, the application range of wind energy storage system will become more and more extensive, and the research and application of single-phase half-wave rectifier circuit based on wind energy storage circuit will also receive more extensive attention and application.

Keywords: Wind energy storage; Rectifier; Capacitance; Multisim.

1. Introduction

Wind power generation has drawn a lot of attention in the context of the worldwide expansion of the low-carbon economy, which has made new energy an increasingly hot topic. As a green and recyclable energy source, wind energy is not only safe, clean, and abundant, but also has the advantages that other energy sources cannot replace. The production of wind energy has a little environmental impact in comparison to other energy sources. Unlike hydropower, which necessitates the construction of dams to hold water for power generation, wind power development just requires the construction of the requisite wind power producing equipment. It will unavoidably cause certain lasting changes to the environment, which will have an impact on the local ecological development, the state of the surrounding wilderness, and occasionally even the lives of the indigenous people. The most serious source of greenhouse gas emissions from the production of electricity is coal-fired thermal power, followed by oil-fired thermal power, less nuclear power, and the least amount of wind power [1]. From an economic point of view, wind power has many benefits, such as not requiring endless investment like thermal and nuclear power, only requiring the development of custom power generation equipment in the early stages and requiring minimal maintenance expenditures in the latter stages. Using wind energy wisely helps lessen environmental pollution as well as the stress brought on by a lack of electricity. In traditional wind power generation, due to the instability of wind power, the voltage directly generated is unstable and cannot be directly used, and further voltage stabilization, energy storage, and conversion are required to achieve normal use. In the wind power storage circuit, the most critical --- rectifier circuit.

In the field of electronic technology, a half-wave rectifier filter circuit is a common circuit structure used to convert alternating current signals into direct current signals. The diode is an indispensable component. It is a semiconductor device with unidirectional characteristics [2]. In a half-wave rectifier circuit, diodes are used to convert alternating current to pulsating direct current. However, such an output voltage is not stable enough and will have a large pulsation component. In order to obtain a DC voltage with a relatively smooth waveform, a capacitor filter circuit is required. The

design and optimization of this circuit structure is of great significance to achieve high-quality DC power supply and ensure circuit stability and reliability. This paper intends to explore the working principle, performance index and optimization method of the circuit based on the half-wave rectifier filter circuit by using tools such as Multisim. It aims to improve the efficiency and stability of circuits and provide technical support and reference for research and application in related fields. The results of this research are of great significance for the development of the electronics industry and related fields. It is expected to provide new ideas and methods for realizing efficient, reliable, and energy-saving circuit design and engineering implementation.

2. Wind energy storage circuit analysis

In general, wind energy is transformed into mechanical energy by wind turbines, which then transforms mechanical energy into electrical energy. Currently, the output energy is alternating current, and then through the controller with a half-wave rectifier circuit. After being transformed into direct current and then stored in the battery pack, the electrical energy that is produced. When the user requires electricity, the inverter transforms the direct current stored in the battery pack into alternating current and sends it down the transmission line to the user's load. Specifically:

(1) According to changes in sunlight, wind speed, and load, the control portion continuously switches and modifies the battery pack's operating state. On the one hand, the DC or AC load is immediately supplied with the adjusted electrical energy. However, extra electrical energy is transferred to the battery pack for storage. Once the battery is fully charged, the controller should keep the battery from being overcharged by sending the electric energy from the battery to the load when the power generation is unable to satisfy the load's needs. The battery's controller should prevent overcharging and battery protection when the battery's electrical energy is discharged. [3]. This guarantees not just the system's continuity and stability, but also its usability and safety.

(2) The system's load balancing and energy regulation depend heavily on the batteries that make up the battery component. It does this by converting the electrical energy produced by the wind power generation system into chemical energy, which is then stored in case there is a power shortage. A lead-acid battery is typically employed, which has an electrode consisting primarily of lead and its oxides. The battery that contains sulfuric acid solution and is classified into exhaust batteries and maintenance-free lead-acid batteries serve as the electrolyte. Lead dioxide is the primary constituent of the positive electrode in the discharge state, while lead is the primary constituent of the negative electrode; Lead sulfate makes up most of the positive and negative electrodes in the charging state. [4].

(3) Several inverters make up the inverter system, which ensures the regular operation of alternating current load equipment by converting the direct current in the battery into conventional 220V alternating current. Additionally, it offers an automatic voltage control feature that can enhance the wind power production system's quality of power delivery.

The topological flow chart of wind energy conversion is shown in Figure 1 below.

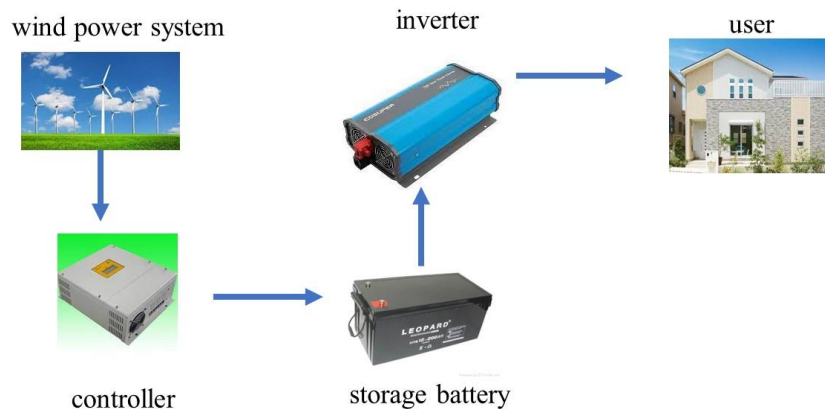

Fig. 1 Wind Power Conversion Flowchart (Photo/Picture credit: Original)

3. Single-phase half-wave rectifier circuit

3.1. Mechanism overview

When the positive half-cycle input signal enters the half-wave rectifier circuit, the diode is forward biased, allowing current to pass through. In this process, the load resistor creates a voltage drop across the circuit and outputs an effective forward one-way current. However, when the negative half-cycle input signal arrives, the diode is reverse-biased and cannot transmit current and voltage signals [5]. Therefore, the signal is completely rejected without any effect on the load resistance. The DC voltage output by a single-phase half-wave rectifier circuit contains a large pulsation component. In order to obtain a smoother DC voltage, a filter circuit needs to be added between the rectifier circuit and the load. Filter capacitors are a common energy storage device. The pulsation component in the circuit can be smoothed out, resulting in an almost stable DC voltage output [6]. When the output voltage of the rectifier circuit rises, the capacitor obtains electrical energy; When the output voltage drops, the capacitor releases the stored energy. The storage and release of this energy can make the DC voltage in the circuit smoother. In addition to mitigating the influence of pulsation components on the circuit, capacitive filter circuits can also absorb interference from external channeling, thereby making electronic circuits work more smoothly. In a capacitive filter circuit, the filter capacitor can be used as an isolation capacitor device to isolate the input signal from the output signal, thereby protecting the load circuit from external interference [7].

3.2. Schematic construction

Diodes are significantly unidirectional. A transformer, a rectifier diode, and a load resistor make up the half-wave rectifier circuit in Figure 2. The transformer converts the alternating current signal into an alternating current signal on the secondary side. The secondary side signal is then changed to a unidirectional DC signal by a rectifier diode, and finally the output voltage U_0 is obtained by the load resistor R_L . In the positive half cycle, the primary side voltage U_1 of the transformer is positive and the secondary side voltage U_2 is also positive. The rectifier diode is now on and the current I_0 flows through the load resistor R_L , and the output voltage U_0 is positive. In the negative half cycle, the primary side voltage U_1 of the transformer is negative and the secondary side voltage U_2 is also negative, currently the rectifier diode is in a reverse blocking state, the current I_0 is zero, and the output voltage U_0 is equal to zero. The output voltage of a half-wave rectifier circuit is only positive and half-cycle, and there is a large ripple because of the voltage drop when the rectifier diode is on. The amount of ripple is related to the load resistance, filter capacitance, and supply frequency. The output voltage is usually smoothed using a filter circuit [6].

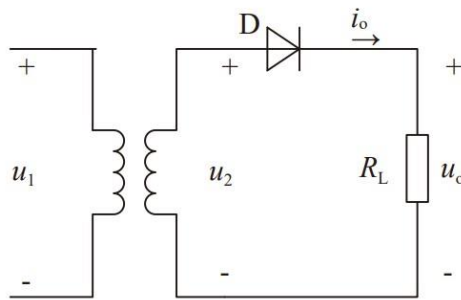

Fig. 2 Half-wave rectifier circuit [6]

Figure 3 depicts the half-wave rectifier filter circuit, which consists of a filter capacitor and a half-wave rectifier circuit. Filter capacitor C is connected in parallel across the load resistor R_L to smooth the output signal and reduce ripple. In the positive half cycle, the rectifier diode turns on and the output voltage U_o equals the supply voltage, while capacitor C is charged and current I_o flows to load resistor R_L and capacitor C . In the negative half cycle, the rectifier diode is reverse-blocked, capacitor C is discharged, and the load resistor R_L supplies current I_o , keeping the output voltage U_o high.

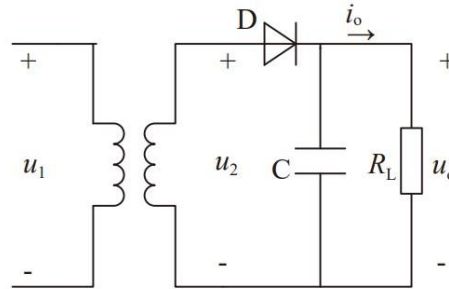

Fig. 3 Half-wave rectifier filter circuit [6]

4. Simulation and analysis

4.1. Introduction to Multisim software

Multisim is a Windows-based simulation tool from National Instruments (NI) Inc. It provides an intuitive and easy-to-use platform for rapid circuit design, prototyping, simulation, analysis, and debugging. Multisim has the following features: First, Simple and easy to use: Multisim provides a clean and intuitive user interface that is easy to learn and use [8]. Users do not need to have too much experience in electronic design to prototype and simulate circuits.

Secondly, High integration: Multisim provides many electronic component models that users can easily select and embed into circuit designs. Multisim can also be integrated with other software such as NI's LabVIEW. Then, Convenient, and fast: Unlike the actual circuit, the construction and modification of the circuit in Multisim is more convenient, and the user can very quickly build, modify the circuit design, and perform a variety of simulation and testing. Additionally, Powerful simulation capabilities: Multisim provides a variety of simulation functions for electromagnetic simulation, digital signal processing simulation, noise simulation, and more. These simulation capabilities greatly improve the efficiency of design and debugging. Finally, Visualization: Multisim provides a variety of graphical analysis tools, including DC, AC, transient, Fourier and other analysis, and users can evaluate circuit performance through a visual interface.

4.2. Half-wave rectifier circuit

On the Multisim platform, select Worksheet in the toolbar. Select the Basic Circuits library in the worksheet and select a diode, a power supply, and an oscilloscope. Drag and drop the diode and power supply into the worksheet, select the diode and power supply, select, and change their parameters

separately. Adjust the supply voltage to 311V, select 1N4001 type for diode type and TEMPLATE_1P25_NON_LINEAR type for transformer. As shown in Figure 4, click the "Analyze" button, run the simulation, and observe the voltage values.

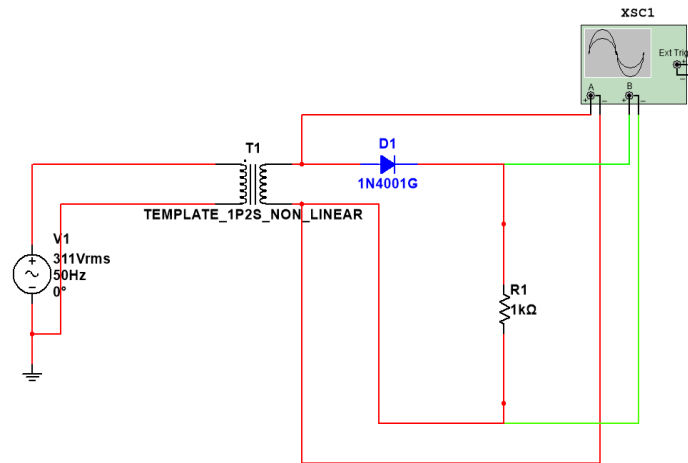

Fig. 4 Simulation model of half-wave rectifier circuit (Photo/Picture credit: Original)

AC power U2 outputs a sinusoidal voltage of 40V peak, which is the input supply voltage. Diode 1 is a rectifier diode with a load resistance of 1000 Ω . During the positive half cycle of U2, the positive potential of the diode is higher than the cathode potential, and the diode is forward, causing a voltage drop and current flowing through the load. In the negative half cycle of U2, the cathode potential of the diode is higher than the anode potential. The diode is reversed cut-off, and no path is formed in the circuit, and no current passes through the load [9]. The process is repeated for subsequent cycles, always outputting a forward voltage across the load, as shown in Figure 5. This circuit only uses half a wave of the power supply voltage, so it is called a half-wave rectifier circuit.

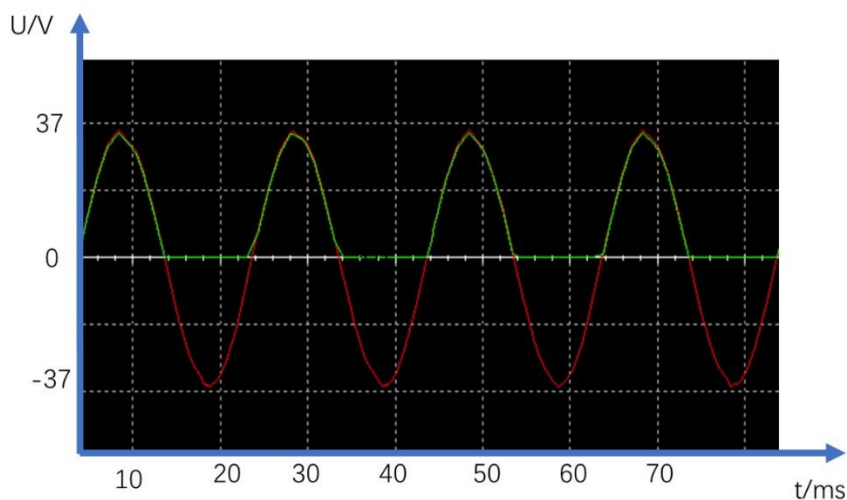

Fig. 5 Half-wave rectification simulation waveform (Photo/Picture credit: Original)

4.3. Half-wave rectifier filter circuit under no-load conditions

Capacitor filtering is a very common way in circuit design, which can effectively smooth the voltage waveform output of the circuit and improve the operation stability of the circuit. The circuit is shown in Figure 6.

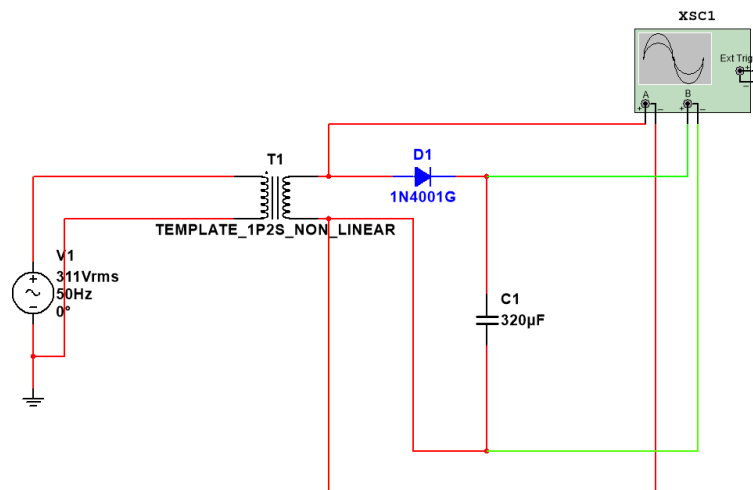

Fig. 6 Simulation Model of Half-wave Rectifier and Filter Circuit under No-load Condition
(Photo/Picture credit: Original)

The no-load half-wave rectifier filter circuit consists of a half-wave rectifier circuit and a capacitor filter. The AC power supply is stepped down by the transformer to form the required voltage, and a diode is half-wave rectified, and capacitor C is used to filter out the AC component in the half-wave rectified DC voltage to obtain a smooth DC voltage output. The circuit is shown in Figure 7.

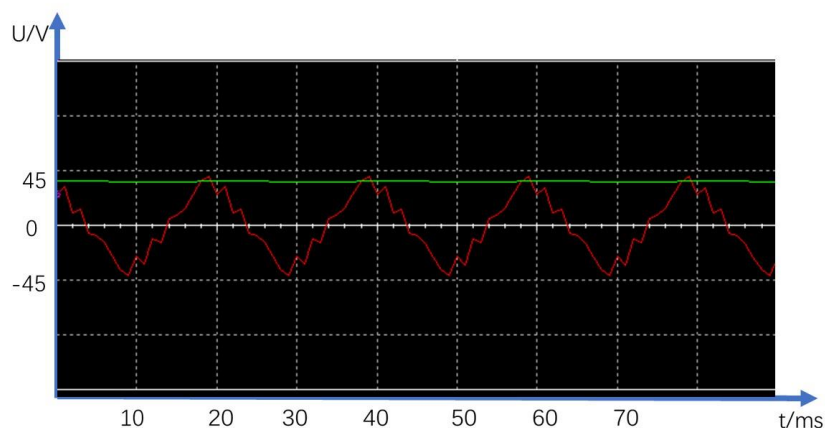

Fig. 7 Simulation waveform of half-wave rectifier filter circuit under no-load condition
(Photo/Picture credit: Original)

4.4. Half-wave rectifier filter circuit under load conditions

In a real circuit, the capacitor filter circuit always carries a certain load. The circuit is shown in Figure 8.

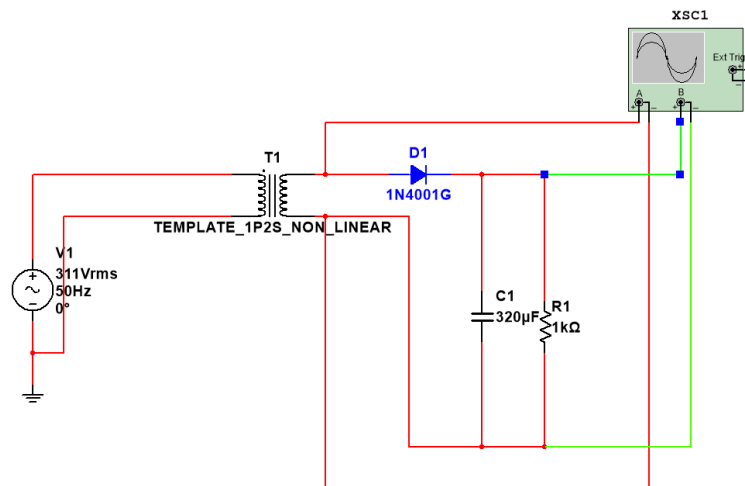

Fig. 8 Simulation model of half-wave rectifier and filter circuit under load condition (Photo/Picture credit: Original)

The load resistance in the circuit affects the capacitor discharge time constant, which in turn affects the waveform and stability of the output voltage [10]. When the load current is too large, the capacitor discharge rate is accelerated, which will cause the waveform of the output voltage to be not stable enough, which will affect the rectification filtering effect. Therefore, under capacitor filtering conditions, the load current is generally small, allowing for a large discharge time constant. The simulation results are shown in Figure 9.

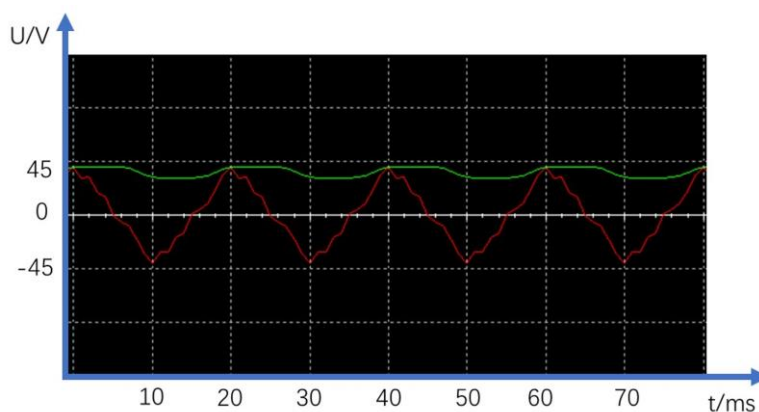

Fig. 9 Simulation waveform of half-wave rectifier filter circuit under no-load condition (Photo/Picture credit: Original)

When designing an actual circuit, it's important to take into account both the load resistance and the capacitor's capacity. A capacitor with a capacity that is too big can increase the circuit's size and expense, as well as affect airflow and heat dissipation. [11]. Thus, when designing a circuit, it is essential to carefully evaluate a variety of elements, choose the right capacitor capacity, and conduct sufficient simulation tests to ensure the stable and reliable performance of the circuit. Typically, if the capacity of a single capacitor is not sufficient to meet the circuit requirements, two capacitors of equal capacity can be considered in parallel across the resistor. This can effectively increase the capacitor capacity and improve the filtering effect of the circuit. Under the condition that other conditions and parameters remain unchanged, the single-capacitor filter circuit and the dual-capacitor filter circuit are compared and simulated. As illustrated in Figure 10, the outcomes demonstrate that the output voltage waveform of the half-wave rectifier filter circuit with the shunt capacitors is smoother. Parallel connection of dual capacitors is equivalent to increasing the capacitance of the capacitor. This reduces the voltage drop across the load. The waveform is gentler. The output average voltage is larger and has good filtering characteristics.

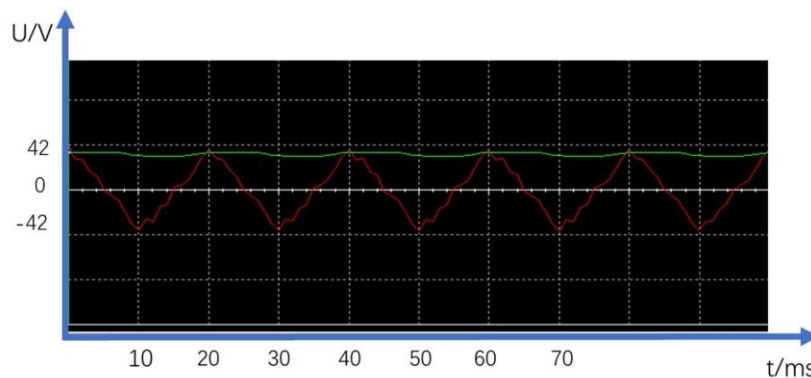

Fig. 10 Simulation waveform of half-wave rectifier and filter circuit under the condition of parallel capacitor (Photo/Picture credit: Original)

4.5. Analysis of results and comparison

A straightforward power rectifier circuit is the half-wave rectifier circuit. The principle is to use a diode to cut off the negative half cycle of the input AC voltage and output the positive half cycle voltage. Nevertheless, because the half-wave rectifier circuit can only utilize the positive half of the voltage source's cycle, its output voltage exhibits a sizable DC drift that can be characterized as a load potential drop [12]. Therefore, in practical applications, half-wave rectifier circuits are mainly used in low-voltage, low-power applications, such as mobile phone chargers, LED lights, etc.

The half-wave rectifier filter circuit at no load can be seen as a pure capacitor filter circuit, where the diode is not loaded, and the capacitor at the output can be fully charged and the output voltage can be stabilized. However, due to the special structure of the half-wave rectifier circuit, its output voltage and output current waveform have significant DC drift, which may cause the accuracy of the output voltage to change. In addition, the larger the capacitance, the better the filtering, but it also makes the output voltage rise and fall longer. A half-wave rectifier filter circuit with a load is required to power the load, and as the load and state of charge vary, so does the capacitor's voltage. If the load changes greatly, it may affect the stability and accuracy of the output voltage. Therefore, in practical applications, circuit design and parameter selection are required for specific load conditions to ensure the quality and stability of the output voltage.

In general, both half-wave rectifier circuits and half-wave rectifier filter circuits have the characteristics of simplicity and low cost, but the stability and accuracy of their output voltages are relatively poor.

5. Conclusion

In summary, capacitive filtering plays a very important role in the half-wave rectifier circuit, which can improve the operating stability of the circuit and the rectification filtering effect. To guarantee the circuit's steady and dependable operation, it is essential to carefully weigh all relevant elements, choose the right capacitor capacity, and do enough simulation tests. A half-wave rectifier filter circuit can be used to charge the battery. The basic principle is to reduce the input voltage to the desired voltage through a transformer. Then the DC voltage is obtained by half-wave rectification, and finally the stable DC voltage output is obtained by capacitor filtering. In the case of load, the output voltage changes depending on the state of charge and load of the battery, so it may affect the SOC (State of Charge) of the battery. Specifically, when the circuit is loaded, the battery needs to consume a part of the power to meet the needs of the load, so its SOC will be reduced accordingly. When the circuit is not loaded, the battery does not need to supply power to the load, and the half-wave rectifier filter circuit will fully charge the capacitor and keep the output voltage stable until the battery is full. The output voltage and output current waveforms of the half-wave rectifier circuit, however, exhibit a substantial amount of DC drift since it can only utilize the positive half cycle of the voltage source.

This can lead to estimation errors for the SOC. In addition, the larger the capacitance, the better the filtering effect. However, it will also cause the output voltage to rise and fall for a longer time, which will affect the charging efficiency of the battery.

Therefore, in practical applications, the half-wave rectifier filter circuit should be properly optimized and adjusted to maximize its charging efficiency and charging accuracy. If higher accuracy and stability are required, power supply filter circuits such as full-wave rectifier filter circuits and three-terminal voltage regulators can be considered.

References

- [1] Riccardo B, Francesca V, Giuseppe R M. Climate change impacts on wind power generation for the Italian peninsula. *Regional Environmental Change*, 2022, 23(1).
- [2] Peng X, Liu Z, Jiang D. A review of multiphase energy conversion in wind power generation. *Renewable and Sustainable Energy Reviews*, 2021.
- [3] Guo Lijian, Xu Weizong, Wei Qi. Demonstration and modeling of unipolar-carrier-conduction GaN Schottky-pn junction diode with low turn-on voltage. *Chinese Physics B*, 2023, 32(02): 525-529.
- [4] Du Chunyu, Jiang Hailong. Modeling and simulation of charge and discharge of lead storage batteries. *Tech Style*, 2023, 524(12): 56-58.
- [5] Yildirim M. Design of low-voltage and low-power current-mode DTMOS transistor based full-wave/half-wave rectifier. *Analog Integrated Circuits and Signal Processing*, 2021, 106(2).
- [6] Na S. Ground Current Suppression for Grid Connected Transformerless Photovoltaic Inverter with Filter Capacitor. *Earth and Environmental Science*, 2021, 621(1).
- [7] Pathic theedn, et al. Testing of inductors using the NI Multisim simulation program. *Journal of Physics: Conference Series*, 2022, 2408(1).
- [8] Xiangjian M, Jingyang F. A half-bridge distributed static compensator with a DC-link filter capacitor of a reduced size LCL filter. *Frontiers in Energy Research*, 2022.
- [9] Li Cuicui, Zheng Guoqing, Wang Jingyi. Simulation of half-wave rectifier circuit based on MATLAB. *Modern information technology*, 2023, 7(04): 54-56.
- [10] Jianna O, Hao B, Shifeng O, et al. Measurement Technology of Grounding Capacitance of Distribution Network Based on the Graded Adjustment of Grounding Transformer Winding. *Asia Pacific Institute of Science and Engineering (APISE)*, 2021.
- [11] Tian Zhongjun. Shunt resistance-capacitive voltage divider based on Multisim. *Journal of Science and Science*, 2022, 42(10): 44-47.
- [12] Li Yan, Yao Liang. Simulation design of single-phase half-wave rectifier circuit. *Digital technology and application*. 2019, 37(12).