

Innovative Design and Application Analysis of Integrated Operational Amplifiers

Ding Chen *

Department of information science and technology, Southwest Jiaotong University, Chengdu, 611731, China

* Corresponding author: 2020112396@swjtu.edu.cn

Abstract. Operational amplifiers in integrated circuits come in many varieties and numbers and are an essential part of electronic systems. Its performance directly affects the accuracy and effectiveness of the whole system. As the market demand for operational amplifiers in different fields is growing day by day, according to different kinds of demand, people have designed a variety of operational amplifier structure. This paper describes the basic characteristics of operational amplifiers and analyzes three basic structures that are extremely relevant for modification circuits. The common-source, common-gate circuit structure op-amp has the advantages of high gain, high input common-mode range, high output swing, and high overall gain bandwidth, so it has been adopted as the most commonly used architecture today and in the future. The current improvements in operational amplifier design are mainly focused on two-stage operational amplifiers, and less on multi-stage operational amplifiers. The folded common source and common gate operational amplifier circuits are characterized by good frequency characteristics, comparatively low power consumption and high bandwidth per unit gain. The demands on the performance of operational amplifiers will become higher and more varied, and more excellent improved circuits are needed.

Keywords: Telescopic, Folded, Two-stage, Operational amplifier.

1. Introduction

With the rapid development of microelectronics and communications business CMOS operational amplifiers are widely used in a wide variety of circuits such as analog-to-digital converters, digital-to-analog converters, filters, video amplifiers and so on [1]. A variety of op amp structures have been designed according to different kinds of requirements. Analog op-amps usually play the role of signal amplification and high-speed output. While pursuing these properties, stability, power consumption, bandwidth and noise are often concerns in design. For example, by analyzing the characteristics of ECG signals and the characteristics of the acquisition electrodes, it is necessary to design an analog front-end circuit for ECG signal acquisition that is portable, low-power and low-noise [1].

The three commonly used structures of op-amps are: folded common source and common gate op-amps, sleeve type op-amps and two-stage op-amps. An analysis of the common basic circuits and their improved circuits can be seen in the article. And the relative applications are listed as follows. Precision integrated operational amplifiers will realize wider applications in more fields, and their study and analysis are necessary.

2. Basic Theory of Operational Amplifiers

2.1. Characteristics of operational amplifiers

An electrical circuit with a very high magnification is called an operational amplifier (OP amp). The feedback network is typically coupled to provide a shared function module in the actual circuit. It is an amplifier with feedback and a unique coupling circuit. The results of addition, subtraction, differential, integral, and other mathematical operations can be the output signal of this device. Operational amplifier is a term used to describe early implementations of analog computers to execute mathematical functions.

The arithmetic accuracy index of an integrated operational amplifier depends mainly on its DC or low-frequency parameters, i.e., input offset voltage and its temperature drift, input offset current, open-loop voltage gain, common mode rejection ratio, power supply voltage rejection ratio, noise voltage, rejection ratio KCMR, supply voltage rejection ratio, noise voltage or noise current. Due to the different requirements for circuits in various fields, integrated operational amplifiers are becoming more and more available and can be more focused on a few specific properties.

2.2. History of Operational Amplifiers

The first generation of operational amplifiers were all manufactured by BJT and were in the typical product was the Fairchild μ A709, which had a very simple external circuit compared to the transistor. A typical product was the Fairchild μ A709, which had much simpler external circuitry than the transistorized the typical product is the Fairchild μ A709, whose external circuitry is much simpler than that of transistor amplifiers, and at the same time is much smaller and lighter. This is also a technical feature of the μ A709 [2].

An important hallmark of the second generation of integrated operational amplifiers is the use of active negative load instead of a collector resistor, thus greatly increasing the open-loop gain. The second-generation op amps avoid using too many PNP tubes. The second-generation op-amps avoid the use of too many PNP tubes, which are only used for the common base differential amplification of the common-emitter-common-base differential amplifier circuit of the input stage [3]. PNP tubes are only used in the input stage of the common-emitter-common-base differential amplifier circuit, and in the circuit structure, the common-base differential amplifier circuit part is adopted. In the circuit structure, the input stage, intermediate amplifier stage is adopted, Input stage, intermediate stage, and output stage are adopted in the circuit structure, and the quasi-complementary emitter is used in the output stage [4]. The circuit structure, process, and specifications have been improved, but the equivalent internal circuit is relatively small. The circuit structure, process and various indexes have been improved, but the internal equivalent circuit is relatively complex. Typical products include Typical products include the μ A741 and LM324 from Century, etc. In 1967, National Semiconductor introduced the LM741 and LM324. In 1967, National Semiconductor introduced the LM301 and the corresponding military model LM101, which are still in use today [5]. In 1967, National Semiconductor introduced the LM301 and a corresponding military model, the LM101, which is still in use today.

The input stage of the third generation of integrated operational amplifiers uses ultra-beta tubes with particularly large current amplification coefficients, which can improve current and voltage amplification while effectively reducing input bias currents, and in terms of precision, also focuses on improving the performance of misalignment and so on. Typical products of this generation include ADI's AD508, AD517, and so on, with input bias currents of less than 5 nA, 1 nA, etc [6]. The third generation of products uses chromium-silicon resistors and excitation trimming technology in the layout design process. The third-generation products use chromium-silicon resistors and excitation trimming technology, and in the layout design process, a thermo-symmetric design is used at the input stage. The third-generation products use chromium-silicon resistors and laser trimming technology, and in the layout design process, a thermo-symmetric design is adopted at the input stage, resulting in an out-of-phase voltage of less than 25 μ V and a temperature drift of less than 0.5 μ V. The temperature drift is less than 0.5 μ V/ $^{\circ}$ C [7]. The third-generation products use chromium-silicon resistors and laser trimming technology. During the product design process, internal compensation and input protection circuits are internal compensation and input protection circuits are incorporated in the product design.

The fourth generation of integrated operational amplifiers adopts the current relatively advanced structure, such as chopper stabilized zero technology, which makes each index closer to the ideal value level, and its manufacturing process reaches the level of large-scale integrated circuits [8]. The Timeline of Operational Amplifiers is shown in figure 1.

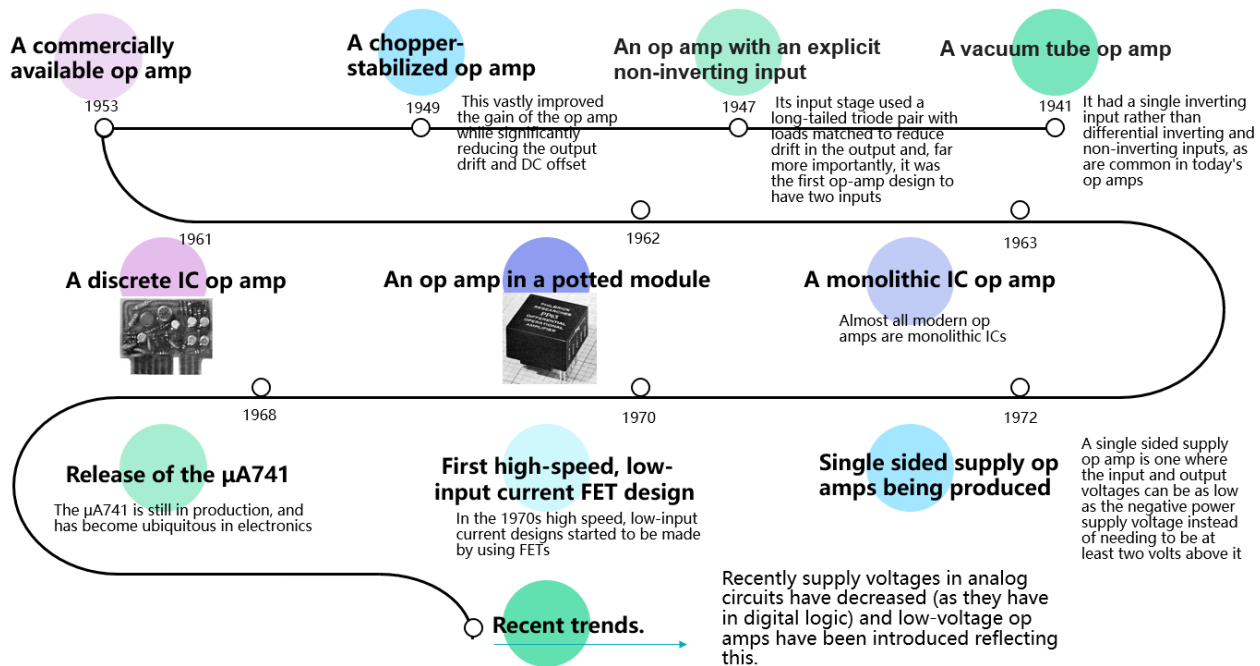

Figure 1. Timeline of Operational Amplifiers (Photo/Picture credit: Original)

3. Common Design and Analysis

3.1. Simple op amp topologie

The main characters are small-signal, low-frequency and the gain on the order of $g_{mN} (r_{ON} || r_{OP})$ which hardly exceeds 10 in nanometer technologies. The bandwidth is usually determined by the load capacitance, C_L . The Simple op amp topologies are shown in figure 2.

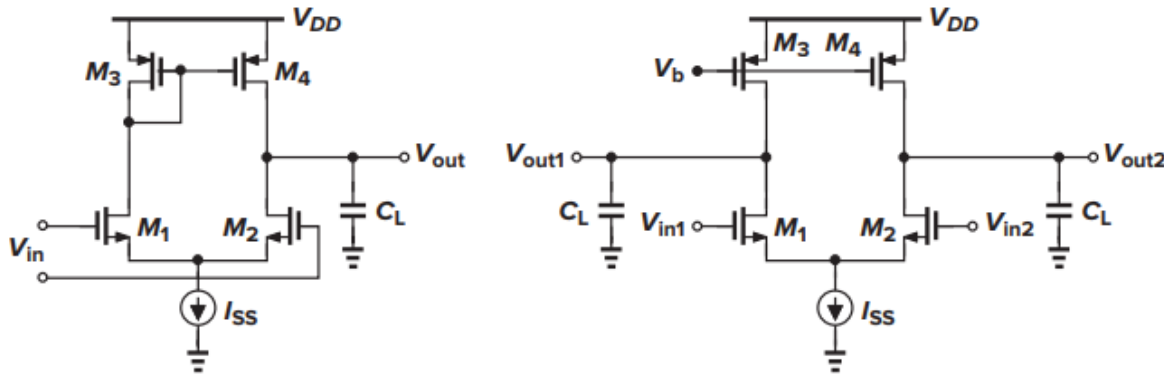

Figure 2. Simple op amp topologie (Photo/Picture credit: Original)

3.2. Telescopic cascode op amps

The differential cascode topologies can be used to achieve a high gain. The gain on the order of $g_{mN} [(g_{mN} r_{ON} || g_{mP} r_{OP})]$. However, the gain improved at the expense of more poles and output swing. The topologie telescopic cascode op amps is shown in figure 3.

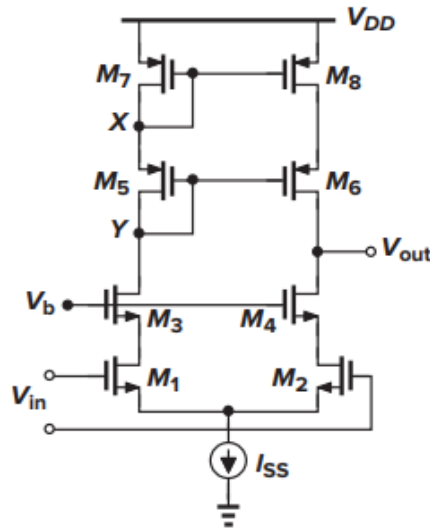

Figure 3. Topologie telescopic cascode op amps (Photo/Picture credit: Original)

3.3. folded-cascode op amp

One of the most commonly used structures for the first stage of single-stage and multistage amplifiers is the folded common-source, common-gate operational amplifier, which has high gain and input/output swing, but is not well suited to the current requirements of achieving the highest performance with the lowest power consumption, mainly because it drives the maximum current from a current source without providing any transconductance to the OTA, and because it has a large limitation on the swing rate.

The folded-cascode op amp topologies is shown in figure 4.

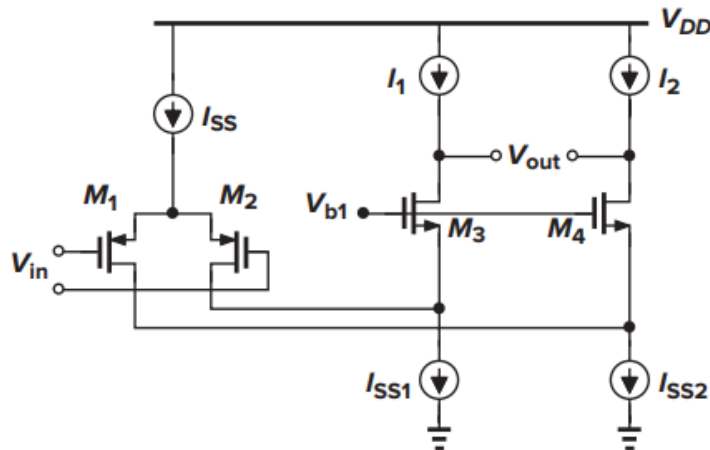

Figure 4. Folded-cascode op amp topologies (Photo/Picture credit: Original)

3.4. Two-stage op amp

The "one-stage" operational amplifiers permit the small-signal current generated by the input pair to pass directly through the output impedance. As a result, the gain of these topologies is constrained to the sum of the output impedance and input pair transconductance. Additionally, a cascode amplifier boosts gain while reducing output fluctuations. The two-stage op amp is shown in figure 5.

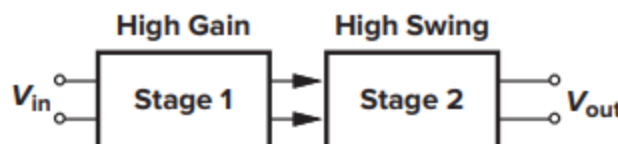

Figure 5. Two-stage op amp (Photo/Picture credit: Original)

Cascode amplifiers' gain and output swings are insufficient for some applications. Op amps in hearing aids, for instance, require a low supply of 0.9 volts to function, although single-ended outputs can swing up to 0.5 volts. To do this, we search for the two-pole op amp's first pole, which offers strong gain, and the second pole, which offers a significant swing. A two-stage arrangement isolates the gain and swing requirements as opposed to cascode op amps.

This paper hardly ever cascades more than two stages in order to increase our profits. It is challenging to provide stability in a feedback system utilizing a multi-stage op amp because each gain stage introduces at least one pole in the open-loop transfer function. The simple implementation of a two-stage op amp is shown in figure 6.

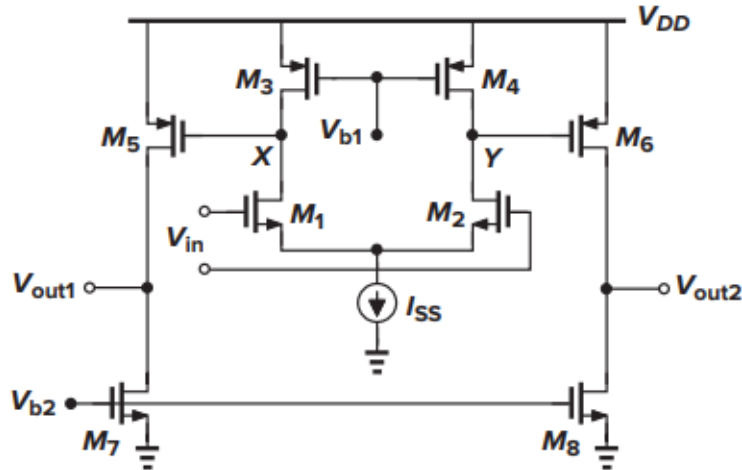

Figure 6. Simple implementation of a two-stage op amp (Photo/Picture credit: Original)

The comparison of performance of 3 op amp topologies is shown in table 1.

Table 1. Comparison of performance of 3 op amp topologies

	Gain	Output Swing	Speed	Power Dissipation	Noise
Telescopic	Nomal	Nomal	High	Low	Low
Folded-Casode	Nomal	Nomal	High	Nomal	Nomal
Two-Stage	High	High	Low	Nomal	Low

4. Innovative Design Research

4.1. A Three-Stage Operational Amplifier for High Precision Capacitance Sensor Circuit

Increase the detection accuracy of the capacitance sensor application specific integrated circuit (ASIC). Increase the detection accuracy of the capacitance sensor application specific. The three-stage operational amplifier topology is shown in figure 7.

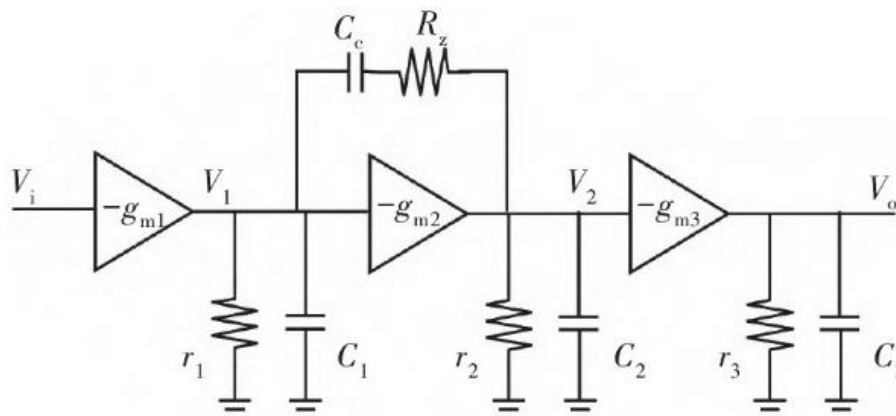

Figure 7. Three-stage operational amplifier topology [9]

The amplifier circuit adopted a cascade structure of three common source stages and was designed as fully differential type. Miller compensation and the tuning of zero to cancel the high-frequency pole were used to guarantee the stability of the amplifier.

Chip test results show that the nonlinearity of the front end of the capacitance sensor circuit using this amplifier is better than 6×10^{-5} . The amplifier has low power consumption, small area, and good reliability, and achieves better comprehensive performance in engineering [9].

4.2. An output stage OPA design for high-speed readout circuit

It permits the readout circuit to function at a frequency greater than 20mhz thanks to a load resistance of 100k and a load capacitance of 25PF. The high-performance output stage operational amplifier is shown in figure 8.

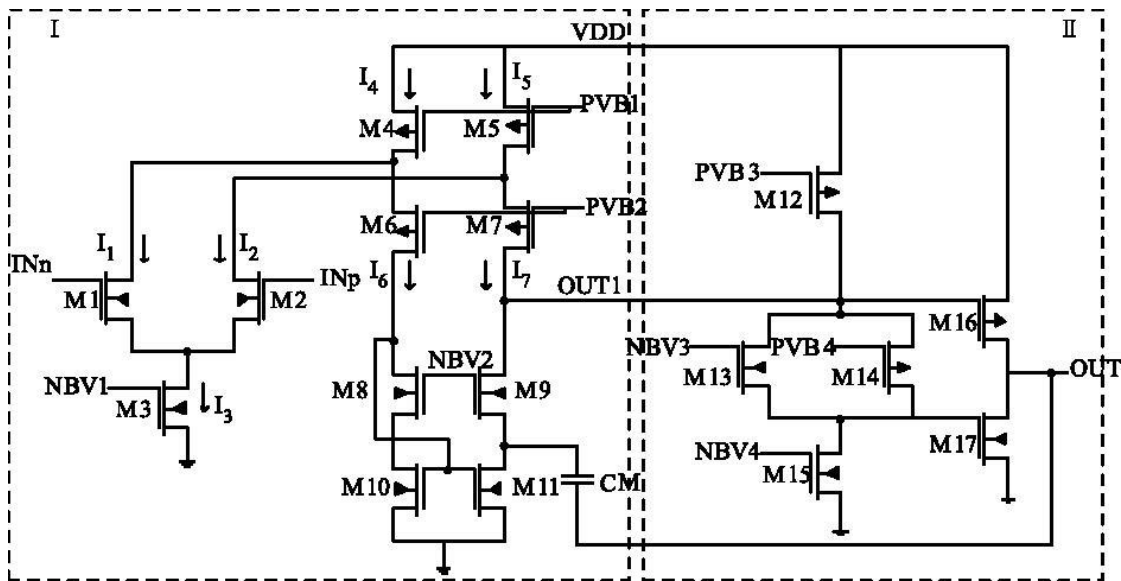

Figure 8. High-performance output stage operational amplifier [10]

Folded cascode OPA can successfully lessen the Miller capacitance effect at the amplifier input while achieving high gain, a wide output voltage range, and high output impedance. Class AB push-pull reversed phase OPA can flexibly take current from or supply current to the load, achieving high current gain, and driving huge loads. It also has a high voltage current conversion efficiency.

It can implement the following parameters: noise of 78v (1-500mhz), power consumption of 10mw, gain of 84DB, phase margin of 79° , unit gain bandwidth of 100mhz, output voltage range of 1-5v, and setup time of 15ns. The readout rate and frame rate of the infrared integrated detector system readout circuit are significantly increased by building a high-speed output stage OPA [10].

4.3. Design of high-gain CMOS folded common-source, common-gate operational amplifiers

Increase the gain of the op-amp. The Complete Operational Amplifier Circuit Architecture is shown in figure 9.

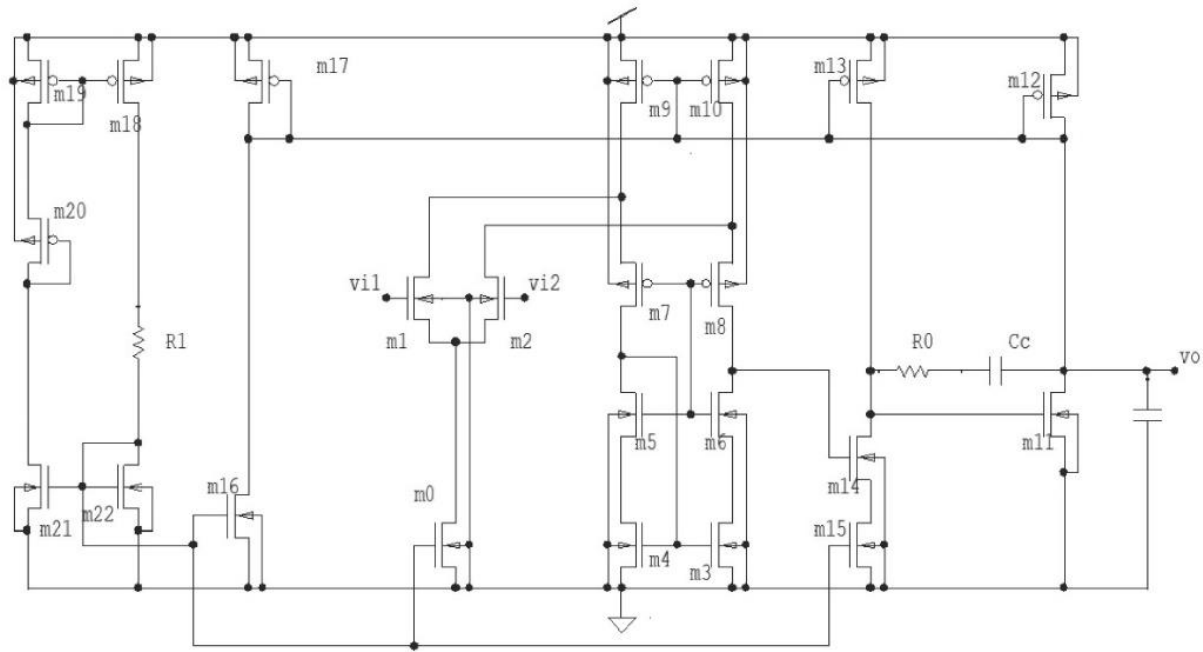

Figure 9. Complete Operational Amplifier Circuit Architecture [11]

The first stage is a common-source, common-gate structure, and the second stage is a common-source amplifier and a zero-canceling resistor, which increases the gain of the op-amp and improves the stability of the circuit [11].

4.4. A high gain bandwidth product high swing rate operational transconductance amplifier

Compared with the conventional structure, the improved folded common-source, common-gate op-amp utilizes an adaptive bias circuit instead of a tail current source. It utilizes an adaptive bias circuit instead of a tail current source to set a low quiescent current, and at the same time, it can generate a large input signal on the differential input pair. This can set a low quiescent current, and at the same time generate a dynamic current on the differential input pair for large input signals without being affected by the tail current source. The improved folded cascode operational amplifier is shown in figure 10.

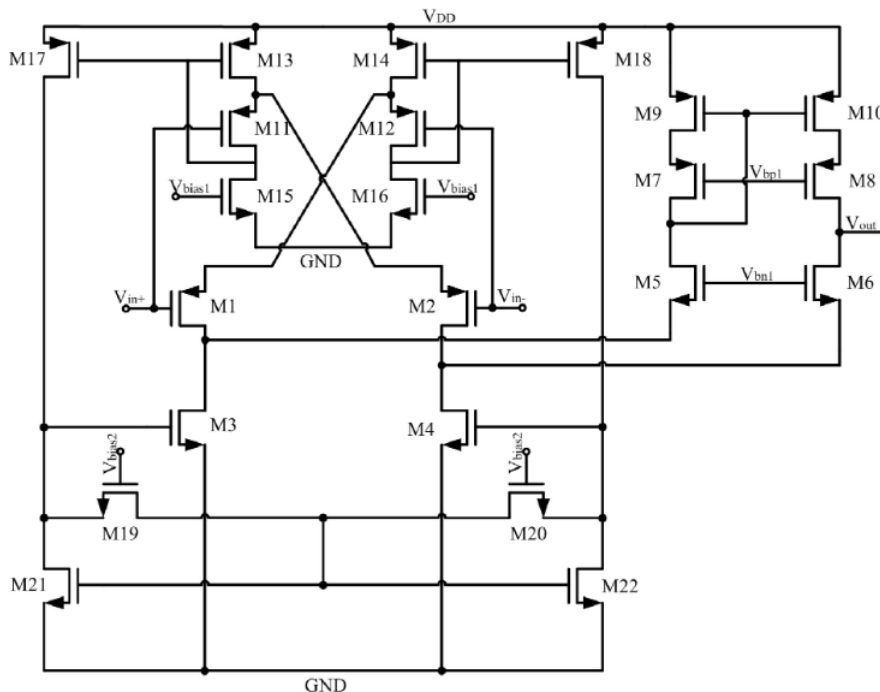

Figure 10. Improved folded cascode operational amplifier [12]

Due to the generation of dynamic currents for big input signals on the differential input pair that are independent of the tail current source, low quiescent currents can be established. The feedback loop drives the inactive folded current source using the current generated by the input transistors that are recycled by the feedback loop. The feedback loop uses the current produced by the input transistors to power the idle folded current source, M3(M4), in order to boost the gain bandwidth and swing rate of the operational amplifier [12].

4.5. Design of a high-gain, high-bandwidth fully differential operational amplifier

A gain-boosting technique is used to design a high gain, high bandwidth, fully differential operational amplifier (op-amp) with a wide input common-mode range, using two folded common source and common gate op-amps with three-input tubes as auxiliary op-amps. The Gain Boost Circuit Schematic is shown in figure 11.

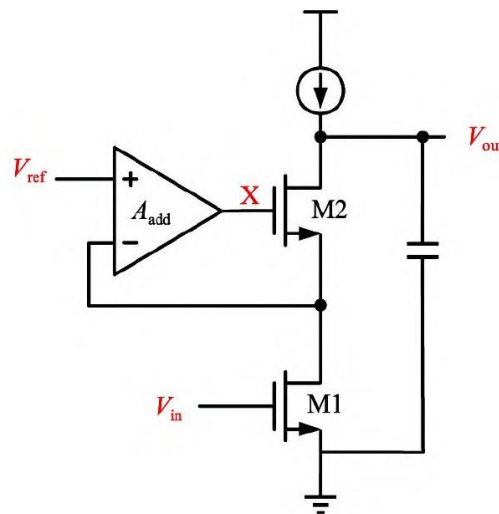

Figure 11. Gain Boost Circuit Schematic [13]

The main op-amp input section consists of a pair of NMOS tubes and a pair of PMOS tubes, and the main op-amp input transconductance is increased to twice that of an op-amp consisting of a single MOS tube. The increase in the main op-amp's input transconductance indirectly increases the main op-amp's gain and bandwidth. While the auxiliary op-amps do not change the bandwidth of the main op-amp, and they increase the gain of the main op-amp again by reducing the main op-amp pole to increase the output impedance, achieving the purpose of high gain and high bandwidth [13].

4.6. Design of an indirect feedback compensated operational amplifier

Aiming at the problems of large compensation capacitance and low bandwidth of traditional Miller-compensated operational amplifiers, an indirectly compensated operational amplifier design is proposed. The operational amplifier is designed using SMIC 180nm CMOS process. The Indirect Feedback Compensation Overall Circuit Diagram is shown in figure 12.

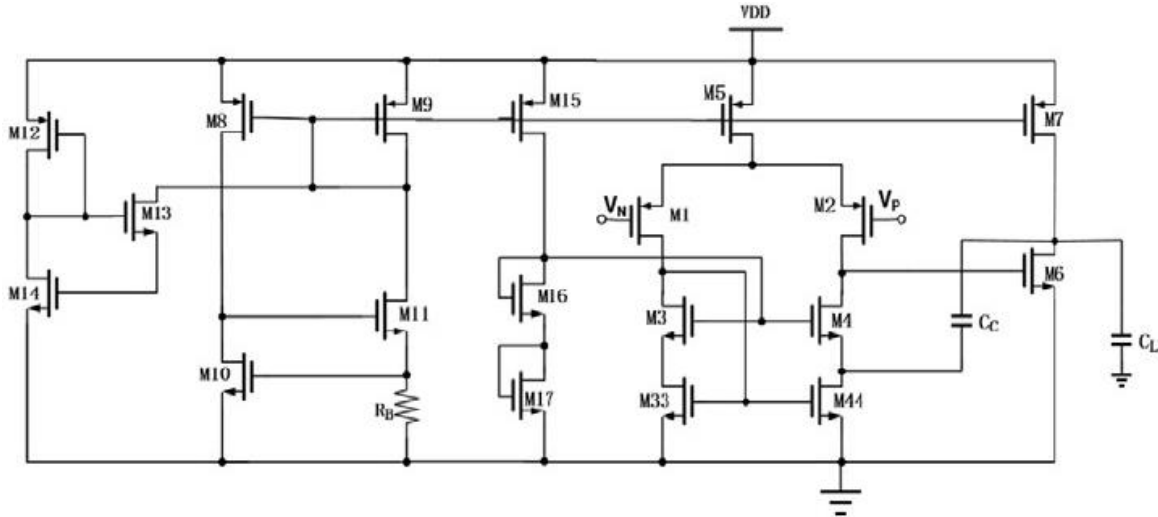

Figure 12. Indirect Feedback Compensation Overall Circuit Diagram [14]

The designed indirect feedback compensated amplifier has similar simulation results as the Miller compensated amplifier, but the indirect feedback compensation has a smaller compensation capacitance, optimizes the design area, eliminates the effect of right half-plane zeros, and has a higher bandwidth. [14].

5. Application Analysis

5.1. Domestic high-precision operational amplifiers for astronautics

High-precision operational amplifiers can be used in different combinations to realize the functions of adders, multipliers, signal generators and so on. multiplier, signal generator, etc. They can be utilized in a variety of converters, including DC-DC, digital-to-analog, analog-to-digital, active filter, data converter, high-speed converter, and others. DC-DC converter, digital-to-analog converter, analog-to-digital converter, active filter, data converter, high-speed digital-to-analog interfaces, amplification systems, and amplifiers are some examples of these devices. The high-performance output stage operational amplifier is shown in figure 13.

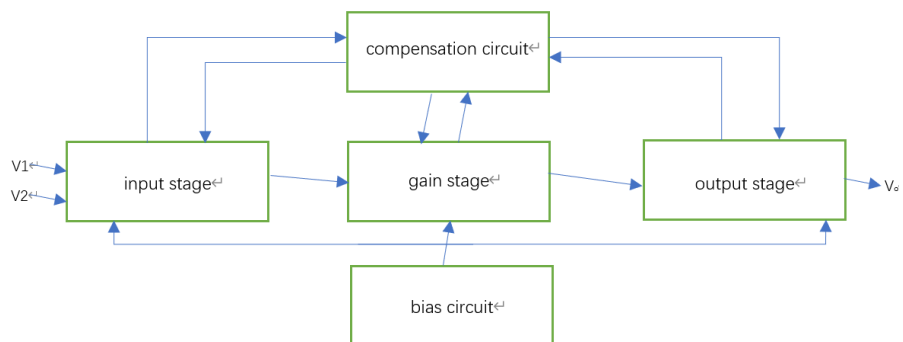

Figure 13. Domestic high-precision operational amplifiers for astronautics [15]

As shown in the figure, domestic high-precision operational amplifiers generally include input stage, gain stage, output stage, bias circuit, and compensation circuit, often using the BJT process, with high output impedance, low bias current, low misalignment, low drift characteristics, low noise and low power consumption and other features [15].

5.2. Integrated Operational Amplifiers in Automotive Applications

Typical applications for integrated operational amplifiers are arithmetic circuits and voltage comparators, which makes integrated operational amplifiers widely used in automobiles. For example:

Subtractive arithmetic circuits form intake pressure sensors and an automotive charging system voltage monitor circuit comprising a voltage comparator. The Intake Pressure Sensor and Subtractive Arithmetic Circuitry is shown in figure 14.

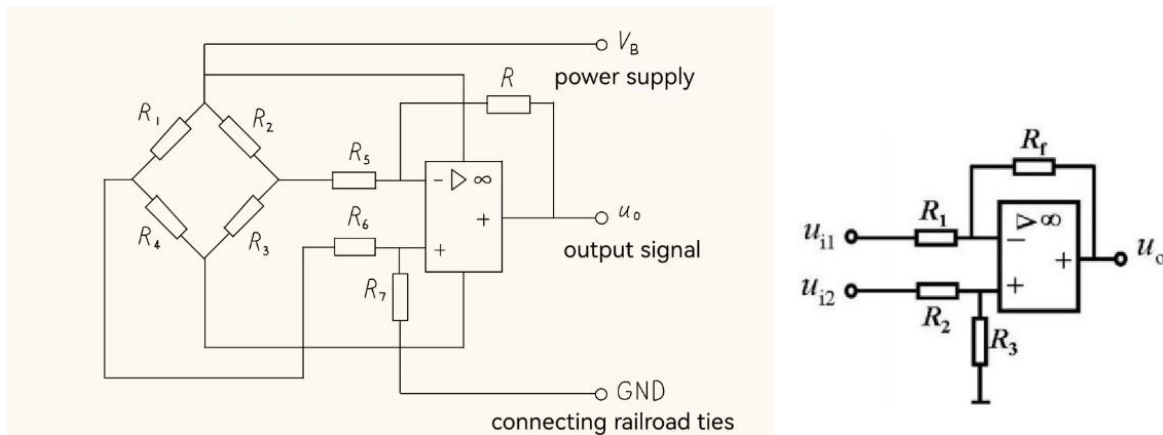

Figure 14. Intake Pressure Sensor and Subtractive Arithmetic Circuitry [16]

For signal amplification, measurement, waveform conversion, and automatic control, integrated operational amplifiers are frequently employed as integrated analog electronic devices. Utilizing the properties of the integrated operational amplifier's linear area, integrated operational amplifiers are primarily used in signaling to create operational circuits. Additionally, integrated operational amplifiers are used in nonlinear regions of signal processing applications, primarily for the development of voltage comparators [16].

5.3. OPA2134

The OPA2134 is the company's FET-input dual operational amplifier, and the OPA2134 family also includes single operational amplifiers. This operational amplifier has been highly rated for its balance of electrical performance, cost, and sound quality. This is why many audio manufacturers have been able to obtain high ratings for their products [17]. The main parameters and pin connections of OPA2134 is shown in figure 15.

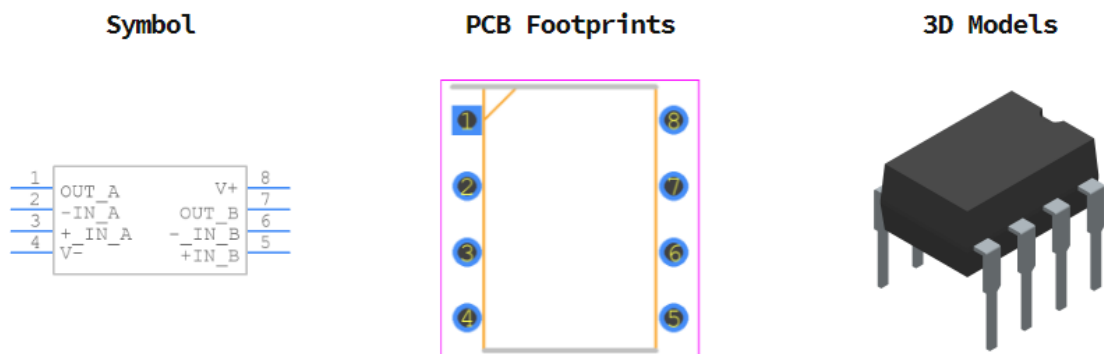

Figure 15. Main Parameters and Pin Connections of OPA2134 [17]

6. Conclusion

People's expectations for equipment performance are rising as more and more automated devices are being used, and in the fields of medical electronics, measuring devices, automotive electronics, industrial automation equipment, and other areas, low-distortion, low-noise, high-precision amplifiers will be used. meters, auto electronics, machinery for industrial automation, and other areas. In addition, and more critically, more and more users are turning their attention to precision technology in terms of single power supply, ease of use, and performance. It is these properties that guarantee customers time-to-market while addressing the challenges of a complete precision signal

chain, thus ensuring success to the greatest extent possible. Operational amplifier performance metrics will be designed to keep pace with the times, moving toward lower voltage and current noise, lower offset voltages, lower offset voltage temperature drift, larger bandwidths, smaller power consumption, and higher voltages for a wider range of applications.

References

- [1] Liao Yuan, Zhang Mengxin, Liu Wenhan, et. Design of a low-power portable multilead ECG signal acquisition system. Cnki, 2019, 38 (05): 53 - 58.
- [2] A. S, V. S, Ramu J, et al. Design and area optimization of CMOS operational amplifier circuit using hybrid flower pollination algorithm for IoT end-node devices. Microprocessors and Microsystems, 2022, 93.
- [3] Alejandro M V, Esteban T, Gerardo L F L D. On the Sizing of CMOS Operational Amplifiers by Applying Many-Objective Optimization Algorithms. Electronics, 2021, 10 (24).
- [4] Lv, Gaochong, Guo, et al. Exact design for the settling time of two-stage Miller compensated operational amplifiers. Analog Integrated Circuits and Signal Processing, 2021 (prepublish).
- [5] Assim A A A, E.V. B. Zero-drift operational amplifiers. Computing, Telecommunication and Control, 2021, 14 (70).
- [6] Aneet S, Kumar S R. Novel Meminductor Emulators Using Operational Amplifiers and their Applications in Chaotic Oscillators. Journal of Circuits, Systems and Computers, 2021, 30 (12).
- [7] Paolo C, Francesco M. Digital Suppression of EMI-Induced Errors in a Baseband Acquisition Front-End including Off-the-Shelf, EMI-Sensitive Operational Amplifiers. Electronics, 2021, 10 (17).
- [8] Milanov I P. Modeling and Simulation of Monolithic Single-Supply Power Operational Amplifiers. Energies, 2021, 14 (15).
- [9] Ren Chen, Yang Yongjun, al. A three-stage operational amplifier for high-precision capacitive sensor circuits. IC Design and Applications, 2022, 47 (04): 53 - 58.
- [10] Zhang Luxuan, Li Jinguo, Yuan yuan, al. An Output Stage Operational Amplifier Design for High-Speed Readout Circuits. Laser infrared, 2022, 52 (09): 53 - 58.
- [11] Xu Yanbin, al. Design of high-gain CMOS folded common-source, common-gate operational amplifiers. Electronics world, 2021 (20): 53 - 58.
- [12] Yang Fan, Zhang Jiahong, Liu Zutao, et. A high gain bandwidth product high swing rate operational transconductance amplifier Electronic Components and Materials, 2023, 42 (5): 598 - 603.
- [13] PENG Chunyu, ZHANG Weiqiang, LIN Zhiting, et al. Design of a high gain, high bandwidth, fully differential operational amplifier. Electronics & Packaging, 2023, 23 (7): 070302.
- [14] Liao Yuan, Zhang Mengxin, Liu Wenhan, et. Design of a low-power portable multilead ECG signal acquisition system. Cnki, 2019, 38 (05): 53 - 58.
- [15] Zhu Yingwei, Sun Haiqin, Li Jin, et. Application Verification Study of Domestic High Precision Operational Amplifiers for Aerospace Applications. Electronic Components and Information Technology, 2021, 5 (3): 120 - 123.
- [16] Zhu Yingwei, Sun Haiqin, Li Jin, et. Application Verification Study of Domestic High Precision Operational Amplifiers for Aerospace Applications. Electronic Components and Information Technology, 2021, 5 (3): 120 - 123.
- [17] Zhang Da, al. Characterization of integrated operational amplifiers and their application in audio amplifiers. Cnki, 2012, 38 (05): 53 - 58.