

TINY HOUSE IN THE DESERT: A study in indoor comfort using moveable insulation and thermal storage

Yuqing He *

School of Architecture, University of Southern California, Los Angeles, United States of America

* Corresponding Author Email: yuqinghe@usc.edu

Abstract. A tiny house for seasonal rangers was designed for the extreme climate and diurnal temperature fluctuations of Joshua Tree National Park. The challenging climate conditions resulted in an extensive investigation of the building envelope to act as a passive thermal storage system to naturally cool and heat the house. The north wall was designed as a "cold battery," which uses a dynamic internal and external insulation system with a high-mass concrete wall to achieve coolth absorption at night as part of a thermal management system and to achieve indoor thermal comfort under extreme desert climates. A combination of opening an exterior insulation system at night to absorb coolth, closing the exterior insulation system when the temperature rises, and opening the interior insulation system to release coolth was attempted. The goal was to achieve a comfortable indoor temperature without the use of HVAC systems. Several software programs were tested for their capabilities to simulate time lag in concrete and thermal storage including Opaque and IES VE. The design of the north wall was carried out for different conditions such as different modulating profiles, locations and thicknesses of insulation, and the data were collected and analyzed again. IES VE was able to successfully simulate the effects of moving interior and exterior insulation twice a day on different sides of a concrete wall. In consideration of the special occupancy type, the expansion of the comfort zone for seasonal rangers is achieved by the specification of a comfortable temperature range from 65°F to 85°F. In a standard year, consisting of 8,760 hours, simulations were conducted on the entire residence, primarily during the months when seasonal rangers were present, to investigate thermal comfort conditions. These assessments encompassed various aspects, including ventilation (2,941 comfort hours), the north wall (4,653 comfort hours), the base model (2,883 comfort hours), and enhancements to the south wall (5,543 comfort hours) and the east and west glazed facade (6,137 comfort hours). The culmination of these findings significantly contributed to an enhanced overall comfort experience within the tiny house design, specifically tailored to accommodate the needs of seasonal rangers at Joshua Tree National Park. Natural ventilation proved to be a good strategy.

Keywords: Precast Concrete; Thermal Comfort; Joshua Tree National Park; Dynamic Insulation/Movable Insulation.

1. Introduction

Joshua Tree National Park in southeast California has an extreme climate with hot summers and cold winters, and minimal rainfall. Seasonal rangers at Joshua Tree National Park typically work for four to six months in the park, so they only need modest housing. A small residence can be designed at Joshua Tree National Park to stay within the comfort range despite the extreme climate, even without HVAC. The climate is a sub-tropical desert, so it is particularly important to ensure the comfort of seasonal rangers indoors without the use of HVAC. To test the most feasible solution, IES VE and other programs are used to simulate various aspects of the building, the site, climate, sunlight, ventilation, interior temperature, thermal comfort, occupancy time, and thermal lag. Special attention is given to the idea that a north wall could be used as a cold battery to store coolth and release it to the interior during the hot summer months.

Tiny houses have been promoted as a new, environmentally friendly housing solution. The term "tiny home" refers to smaller transportable dwellings and measures 8 feet wide by 10 to 20 feet long [1]. Tiny houses can reduce per capita GHG emissions by up to 70% compared to traditional houses, contributing to the 7% annual growth of the small house market [2]. The "tiny house movement" has

gained increasing public recognition, with the United States being one of the countries most affected, which aims to reduce the environmental impact and increase affordability by reducing spatial footprint [3].

2. Background and Literature Review

Precast concrete is created by pouring concrete into molds that are cured offsite and transported to the construction site. It is a useful solution for building tiny houses in JTNP due to its ability to address climate and earthquake risks [4], provide thermal comfort, adapt to desert conditions, ensure quality assurance, increase construction efficiency and safety, and fire and water resistance. For fabrication and transportation, the small residence was determined to be 28 ft (L) × 8 ft (W) × 9 ft (H). Windows are placed on the eastern and western sides for ventilation, while 4-inch buffer spaces are provided to minimize direct solar heat into the building. The 5" concrete north wall meets weight requirements for structural, transportation and thermal storage capacity, and the size was configured for maximum dimensions for semi-trailer transportation and the maximum weight for crane lifting (Fig. 1).

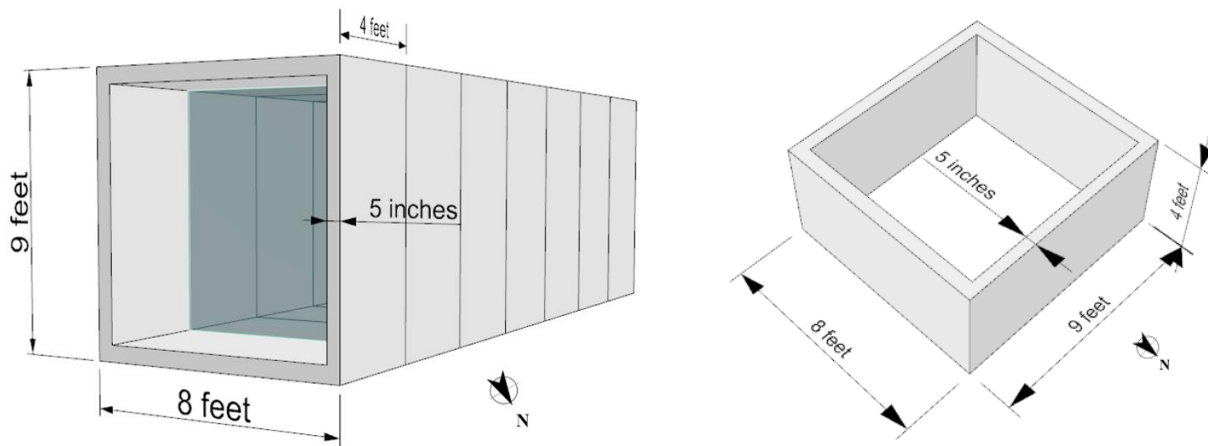

Fig 1. Rhino model of the preliminary tiny house.

Thermal comfort is defined as the human satisfaction with their thermal environment, based on the energy balance between the environment and the human body [5]. Ventilation systems can improve indoor air quality and occupant comfort. According to ASHRAE Standard 55, the ideal temperature for thermal comfort is between 67 and 82 °F [6]. For the purposes of the analysis, comfort zone will be expanded for this special group of occupants and will range between 65 and 85°F in the interior.

Dynamic insulation is a promising strategy, as it enables regulated variation in the rate of heat transfer through building envelopes over time [7]. A cold battery is a dynamic internal and external wall system formed by two layers of insulation. A combination of opening the exterior insulation at night to allow the concrete middle layer to absorb coolth, closing the exterior insulation when the temperature rises, and opening the interior insulation to release coolth from the concrete can help achieve a comfortable indoor temperature (Fig. 2).

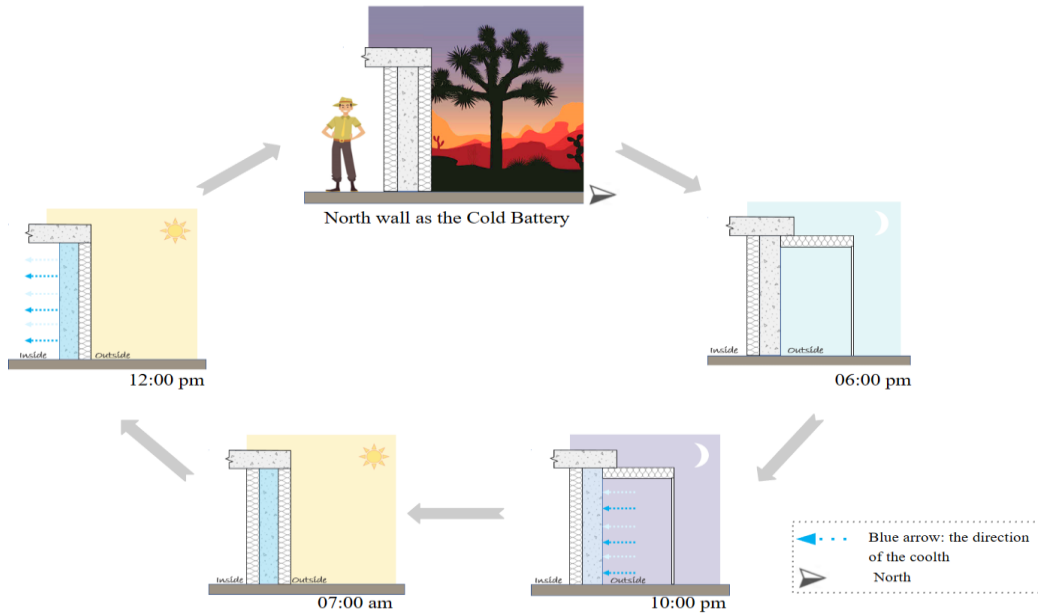

Fig 2. Cold battery workflow.

3. Design Background and Simulation Methodology

The methodology was divided into two parts: team collection and individual collection. The green section is specifically the north wall study, which mainly includes climate, comfort zone, 3D models, thermal mass, thermal lag and dynamic insulation. The red and blue sections are team members' studies on the south wall and roof. After finishing the simulation and results of each section, consolidating the data, and then creating the pocket lodge combined model for further study, including south wall hot battery and the east-west glass wall (Fig. 3).

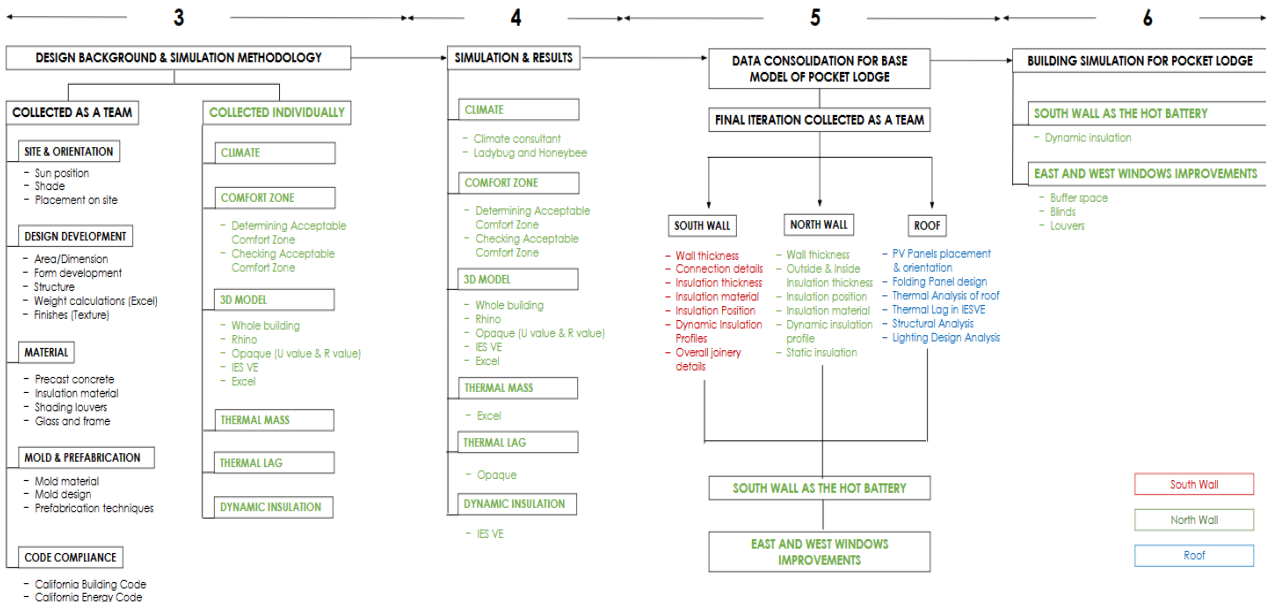

Fig 3. 3 – 6 Organization.

4. Simulation and Results

4.1. Study of First Model Ventilation Using East/West Walls

MacroFlo is a tool in IES VE for analyzing natural ventilation in structures. The IES VE model is set in ModelIT, openings are created on the west and east sides of the small residence (Fig. 4).

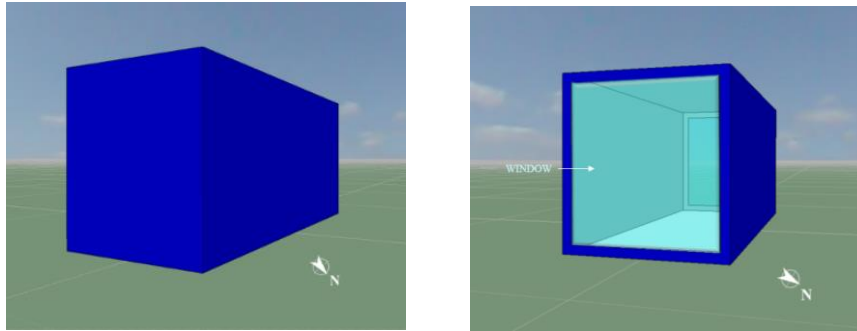

Fig 4. Simple shoe box with east and west windows in IES VE.

The optimal window opening condition is that if the room air temperature is greater than equal to 82°F and outside air temperature is less than room air temperature, or if room air temperature is less than or equal to 67°F and outside air temperature is greater than room air temperature. If either conditions is satisfied, the windows will open simultaneously. The number of hours in a year (8,760 hours) was divided into three parts: above 65°F, between 65°F and 85°F, and below 85°F. There are 3,795 hours below 65°F, 2,941 hours between 65°F and 85°F, and 2,024 hours above 85°F.

4.2. Study of North Wall: Comfort Hours and Time Lag

The north wall cold battery is established in ModelIT in IES VE (Fig. 5).

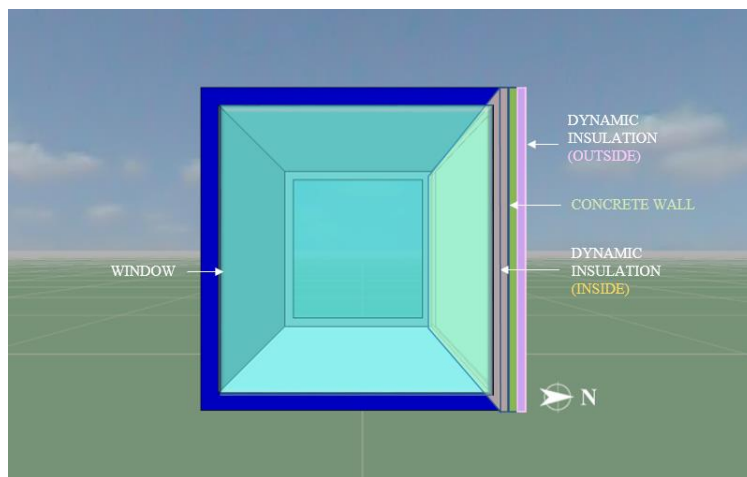

Fig 5. Looking through the east window wall – the north wall is the cold battery

Dynamic insulation operations based on daily profiles. Seasonal ranger’s work schedule is from 8 am to 5 pm. The outside dynamic insulation is set to open at night (6 pm to 7 am), and close during the day (7 am to 6 pm). The inside dynamic insulation is set to open during the day (7 am to 6 pm), and close at night (6 pm to 7 am). 1 means open, and 0 means closed (Fig. 6).

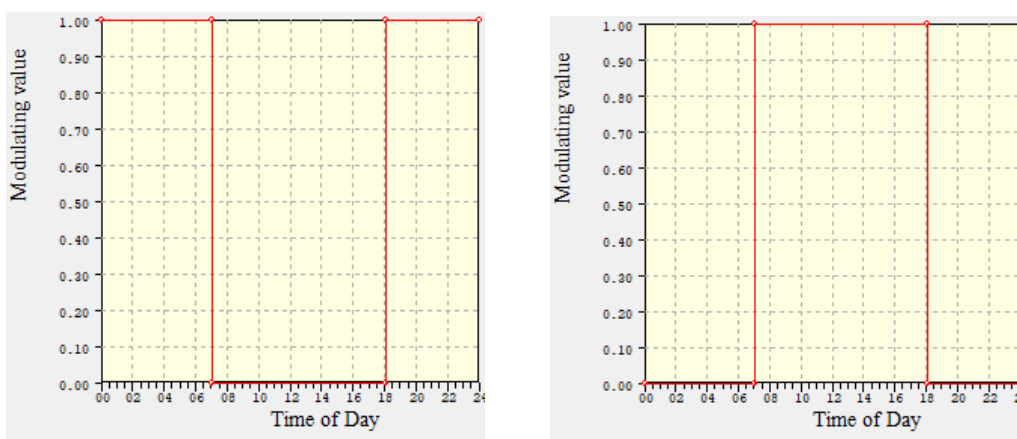

Fig 6. The outside and inside dynamic insulation daily profile

In Jan. and Dec., the dynamic outside insulation should be closed, and the dynamic inside insulation should be opened during the day and closed at night. In Feb., Mar., Apr. and Nov., dynamic outside insulation should be closed and dynamic inside insulation should be opened. From May to Sep., the dynamic outside insulation should be open during the night and closed during the day, and the inside dynamic insulation should be opened. There are 2,261 hours below 65°F, 4,653 hours between 65°F and 85°F, and 1,846 hours above 85°F throughout the year.

OPAQUE was used to determine U-values, R-values, decrement factors, and time lag (Fig. 7).

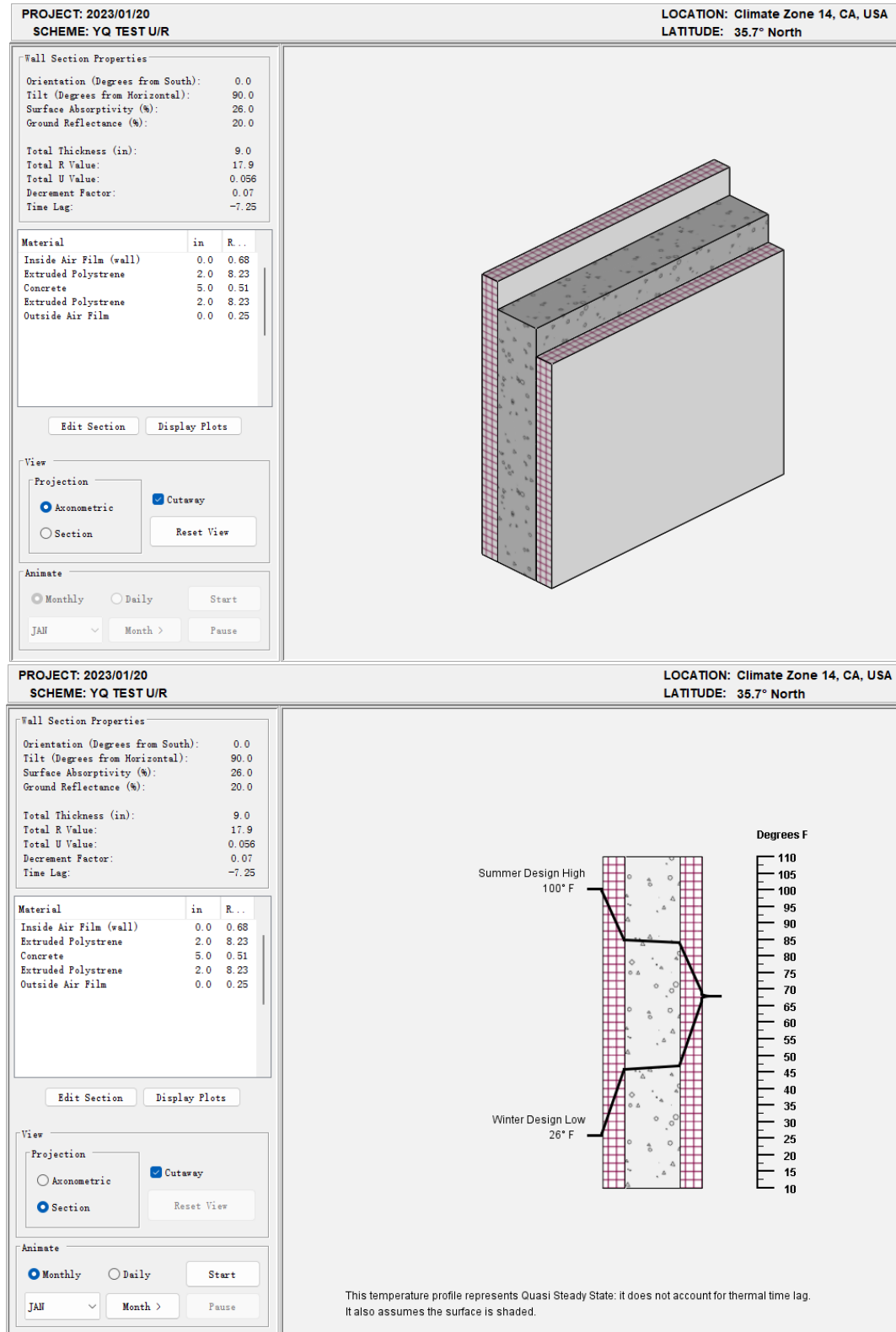

Fig 7. OPAQUE sample model.

In OPAQUE, different tests was conducted:

1. Concrete of different thicknesses, including 3", 4", 5", 6", 7", 8", 9", 10", 11", 12", 13", 14", 15", 16", 17", 18", 19", and 20".
2. Various expanded polystyrene (EPS) thicknesses, including 1", 2", 3", 4", and 5", and their placement in various positions on a 5" concrete wall, including outside, inside, and on both sides.
3. Various extruded polystyrene (XPS) thicknesses, including 1", 2", 3", 4", and 5", and their placement in various positions on a 5" concrete wall, including outside, inside, and on both sides.

In regions that have significant fluctuation temperature, time lag is particularly crucial for building design. The low nighttime temperatures will reach the internal surfaces around midday, cooling the interior room, if materials with a thermal lag of 10 to 12 hours. The thickness of the concrete has a positive correlation with the time lag. When the concrete wall thickness is between 14 and 18 inches, the time lag reaches the interval of 10 to 12 hours. Instead, the time lag starts to decrease when the concrete thickness exceeds 18 inches. The time lag ranking for EPS is same as XPS: both sides > outside > inside. When materials are the same thickness and position, XPS has more thermal lag hours than EPS. Using XPS is more beneficial for the time lag of the north wall, however, EPS is considered a more environmentally-friendly and cost-effective choice. Therefore, 3 inches of EPS was elected for the interior and exterior (Fig. 8).

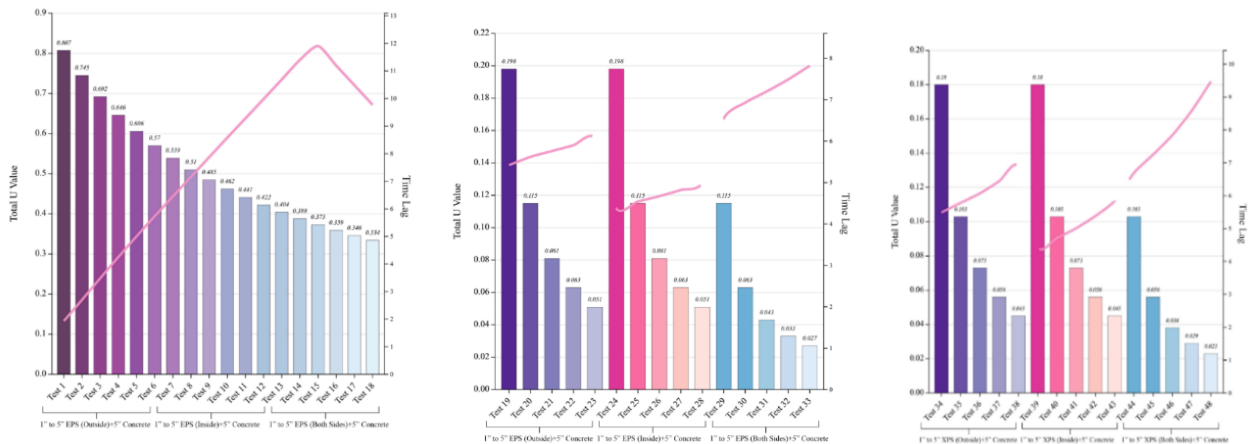

Fig 8. Relationship of concrete, EPS and XPS for U value and Time lag, in hours.

5. Data Consolidation for Combined Model of Pocket Lodge

5.1. Study of the Combined Model: South Wall

The south wall of combined model is composed of 8" concrete wall and 3" both sides EPS insulation. The outside insulation of opening time is 11 am to 5 pm in winter, 8 am to 6 pm in spring, 11 pm to 4 am in summer, and 10 pm to 9 am in fall. The inside insulation of opening time is 9 pm to 8 am in winter, 11 pm to 7 am in spring, 8 am to 12 pm in summer, 11 am to 6 pm in fall.

5.2. Study of the Combined Model: Roof

The roof of combined model is composed of a 5" concrete wall and 3" interior EPS insulation. The roof insulation is set to close in winter and summer, 6 pm to 11 am in spring, and open in fall.

5.3. Study of the Combined Model: South Wall and Roof

The profiles for south wall and roof are all derived from the best results of simulations. There are 4,003 hours below 65°F, 2,883 hours between 65°F and 85°F, and 1,874 hours above 85°F throughout the year (Fig. 9).

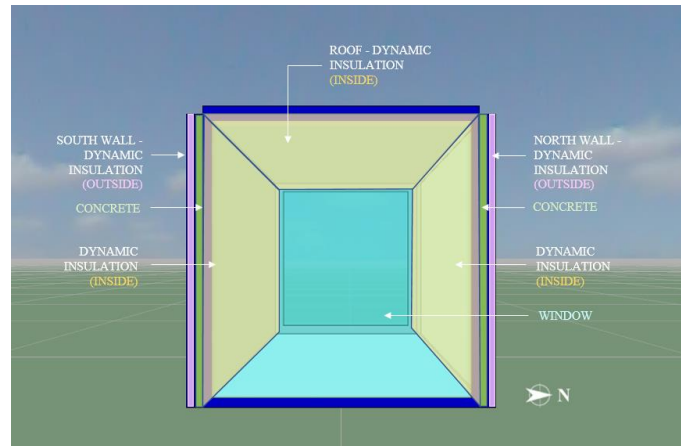

Fig 9. Looking at the east window wall – final iteration of the combined model.

6. Building Simulation for Pocket Lodge

The improved combined model update south wall and east and west glazed facade (Fig. 6.1).

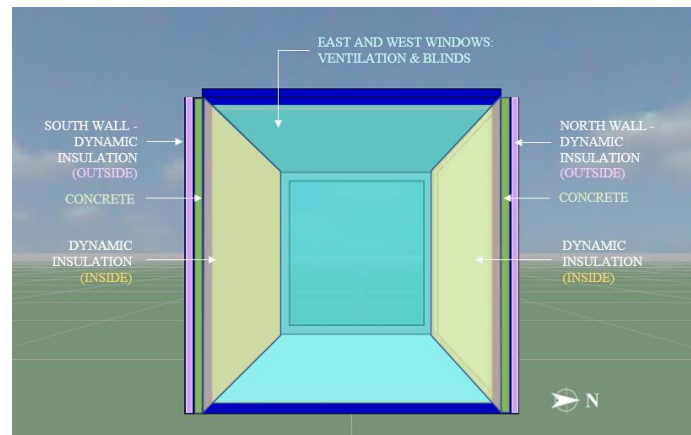

Fig 10. Improved combined model.

6.1. South Wall As the Hot Battery

According to seasonal rangers' work schedule, two profiles are set for the hot battery. One dynamic insulation profile opens at night (6 pm to 7 am) and closes during the day (7 am to 6 pm), and another profile opens during the day (7 am to 6 pm) and closes at night (6 pm to 7 am) (Fig. 11).

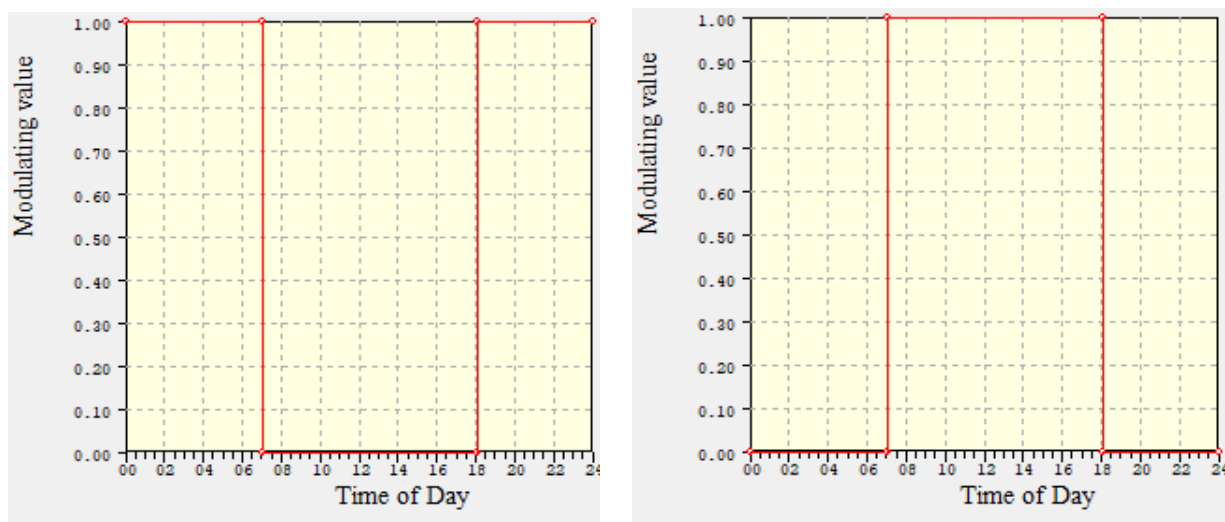

Fig 11. South wall hot battery daily profile – day close, night open / day open, night close.

The south wall dynamic insulation opening condition is that in Jan., the inside dynamic insulation should be closed during the day and opened at night, and the outside dynamic insulation should be closed. In Feb. to Apr., and Nov., the inside dynamic insulation should be opened and the outside dynamic insulation should be closed. In May, Sep., and Oct., the inside dynamic insulation should be opened, and the outside dynamic insulation should be closed at night and opened during the day. From Jun. to Aug., the inside dynamic insulation should be opened during the day and closed at night and the outside dynamic insulation should be opened. In Dec., the inside dynamic insulation should be opened during the day and closed at night, and the outside dynamic insulation should be closed. There are 1,344 hours below 65°F, 5,543 hours between 65°F and 85°F, and 1,873 hours above 85°F throughout the year.

6.2. East and West Glazed Facade Improvements

Removing the buffer space and adding blinds indoors is a feasible way to increase indoor comfort hours, and greatly reducing underheat hours throughout the year. There are 753 hours below 65°F, 6,137 hours between 65°F and 85°F, and 1,870 hours above 85°F throughout the year.

7. Conclusions and Future Work

Comparing whole year comfort times for the four model studies, the improved combined model has 70% comfort hours, followed by north wall model at 53%, and first model ventilation at 34%. The combined model with all team components has the lowest comfort hours at 33% (Fig. 12).

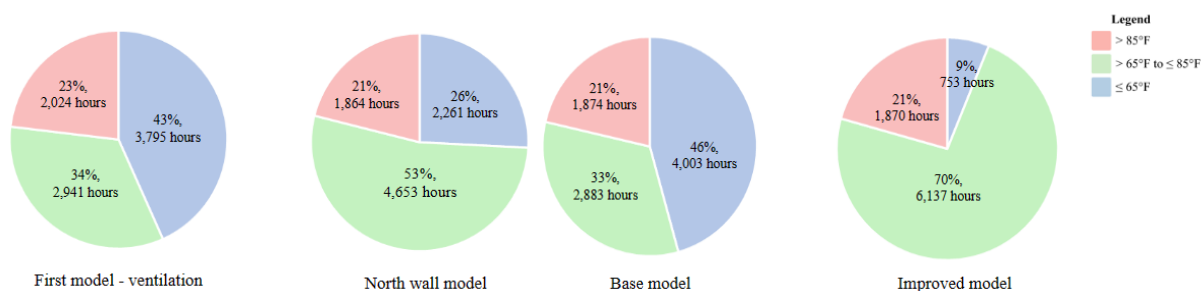

Fig 12. First model ventilation, north wall, combined model, improved combined model.

In the future, to improve the results of the study, three areas could have been more thoroughly explored: methodology, visualization, more expertise on IES VE, and real fabrication of precast concrete components. Overall, passive methods were very successful for the design of a tiny house for seasonal rangers at Joshua Tree National Park.

Acknowledgements

I would like to dedicate this thesis to my 24th year of life, which was full of passion and courage, and especially to my golden student years. I am grateful for the opportunities and experiences that have come my way, and for the people who have been a part of my journey.

I am deeply grateful to the University of Southern California for providing me with a world-class education and unforgettable experiences during my time as a graduate student in the Chase L. Leavitt Master of Building Science program at the USC School of Architecture.

I extend my sincerest gratitude to my thesis committee chair, Professor Douglas E. Noble, and committee members, Professor Karen M. Kensek, Professor Marc Schiler, Professor Mic Patterson, and Professor Gideon Susman, who have been invaluable mentors throughout my academic journey. Your unwavering dedication, profound expertise, and passion for the field of architecture have not only guided me but also inspired me to pursue my academic and personal goals with confidence and determination.

The impact of all the professors I am grateful to has been immeasurable, and I deeply appreciate the profound influence you have had on my growth, both academically and personally. I would also like to extend my appreciation to my classmates, Aditya Bahl and Archana Janardanan, for their invaluable contributions in completing this thesis.

Furthermore, I want to express my sincere appreciation and gratitude to my family and friends for their unwavering support and encouragement throughout my master's program. Your unwavering love and support provided me with the strength and confidence to face any challenge and helped me become the person I am today.

Studying at USC has truly been an unforgettable experience, and I am proud to be a part of the Trojan Family. I will always cherish the memories and experiences that I have had at USC.

Thank you, USC, for everything!

Fight on!

References

- [1] Anson, April. "The World is my Backyard: Romanticization, Thoreauvian Rhetoric, and Constructive Confrontation in the Tiny House Movement." *Research in Urban Sociology*, vol. 14, 2014, pp. 289–313.
- [2] ASHRAE and the American National Standards Institute. "Thermal Environmental Conditions for Human Occupancy5-2017," 2020, www.ashrae.org.
- [3] Crawford, R. H. and Stephan, A. "Tiny house, tiny footprint? The potential for tiny houses to reduce residential greenhouse gas emissions." *IOP Conference Series: Earth and Environmental Science*, vol. 588, pp. 022073, 2020.
- [4] Fanger, P. O. "Thermal Comfort: Analysis and Applications in Environmental Engineering." Danish Technical Press. Copenhagen, Denmark, 1970.
- [5] Fawaier, M. and Bokor, B. "Dynamic insulation systems of building envelopes: A review." *Energy and Buildings*, 270, 112268, 2022.
- [6] Ghayeb, H. H., Razak, H. A., and Ramli Sulong, N. H. "Performance of dowel beam-to-column connections for precast concrete systems under seismic loads: A review." *Construction and Building Materials*, 237, 117582, 2020.
- [7] Shearer, H. and Burton, P. "Towards a Typology of Tiny Houses." *Housing, Theory and Society*, 36, 298–318, 2018.