

Comprehensive Analysis of DC/DC Converters for Electric Vehicles Applications: Topologies and Future Perspectives

Xianda Wang*

LUT School of Energy System, Lappeenranta University of Technology, Lappeenranta, Finland

*Corresponding author: Xianda.Wang@student.lut.fi

Abstract. In order to implement the global sustainable development strategy, reduce the burden of traditional fuel vehicles on the environment, and at the same time, due to the increasing oil prices, more and more people are reluctant to use fuel vehicles, the global automobile industry. The centre of gravity has gradually shifted from traditional industrial energy vehicles to electric vehicles. As an integral part of the electric vehicle powertrain, the DC/DC converter has the important function of supplying power to the power steering system, air conditioning and other auxiliary equipment. This paper describes in detail the DC/DC converters that provide power for electric vehicles, describes in detail the different types of DC/DC converters as well as the different topologies, and analyses the characteristics of each topology and the method of providing power to the circuit by drawing the circuit of the different topologies. Next, the advantages and disadvantages of various topologies are compared, and improvement methods and future prospects are proposed for the shortcomings of different topologies.

Keywords: DC/DC converter, Buck, Boost, Full-bridge converter, Topology.

1. Introduction

In recent years, with the continuous development of science and technology, more and more non-renewable energy sources, such as crude oil, have been put into the automobile industry, which has brought about a series of energy problems and a large amount of greenhouse gas emissions [1], in order to implement the global sustainable development strategy, reduce the burden of traditional fuel vehicles on the environment, and at the same time, due to the increasing oil prices, more and more people are reluctant to use fuel vehicles, the global automobile industry. The centre of gravity has gradually shifted from traditional industrial energy vehicles to electric vehicles. There are three types of electric vehicles, namely plug-in hybrid electric vehicles (PHEV), hybrid electric vehicles (HEV) and pure electric vehicles (BEV). Fuel vehicles are equipped with a low-voltage generator assembly, whose function is to charge the on-board 12V or 24V low-voltage battery and provide all low-voltage power for the whole vehicle; while in new energy vehicles, the generator is replaced by a DC/DC converter, which obtains power from the on-board power battery (400V/800V), charges the on-board 12V or 24V low-voltage battery, and provides all low-voltage power for the whole vehicle. Electrical vehicles can use power from a variety of sources, including emerging renewable energy generation, and benefit from lower fuel (electricity) costs [2].

As an integral part of the electric vehicle powertrain, the DCDC converter has the important function of supplying power to the power steering system, air conditioning and other auxiliary equipment. Another function is embodied in the composite power system, the converter is connected in series with the super capacitor to regulate the power output and stabilise the bus voltage. one end of the DC/DC converter is connected to the power battery, and the other end is connected to the low-voltage battery; it can provide power for the whole vehicle electrical appliances as well as charging for the auxiliary batteries, and its function in the pure electric vehicle is comparable to that of a generator and a regulator in a traditional fuel vehicle [3]. The structure shown in Fig. 1 is the basic power structure of an electric vehicle.

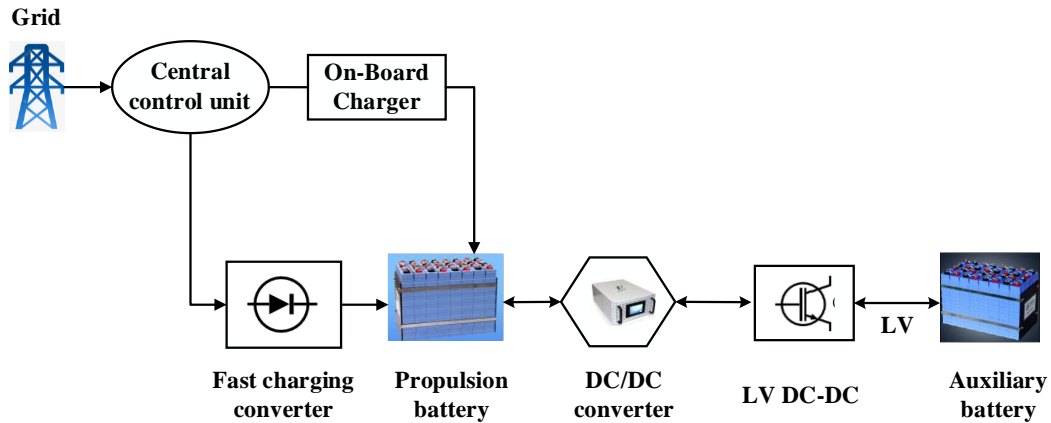

Fig. 1 The structure of an electrical vehicle [3]

Different types of DC/DC converters have different efficiencies in electric vehicles. There are two types of on-board DCDC converters for electric vehicles, one is isolated and the other is non-isolated. Electrical isolation is to electrically separate the power supply from the power circuit, i.e., to isolate the branch circuits of the power supply from the entire electrical system, so as to make it an electrically isolated, independent and ungrounded safety system, in order to prevent the risk of indirect electric shock in the event of a faulty charged bare conductor. The role of electrical isolation is mainly to reduce mutual interference between two different circuits and to reduce noise. Non-isolated DCDC circuits have a simpler structure where each component is directly connected. The main non-isolated topologies are Buck topology converter, Boost topology converter, Buck-Boost topology converter. The main isolated DCDC topologies are forward topology converter, flyback topology converter, full-bridge topology converter, and so on. Fig. 2 mainly describes shows the classification of different isolated as well as non-isolated DCDC converter topologies [4].

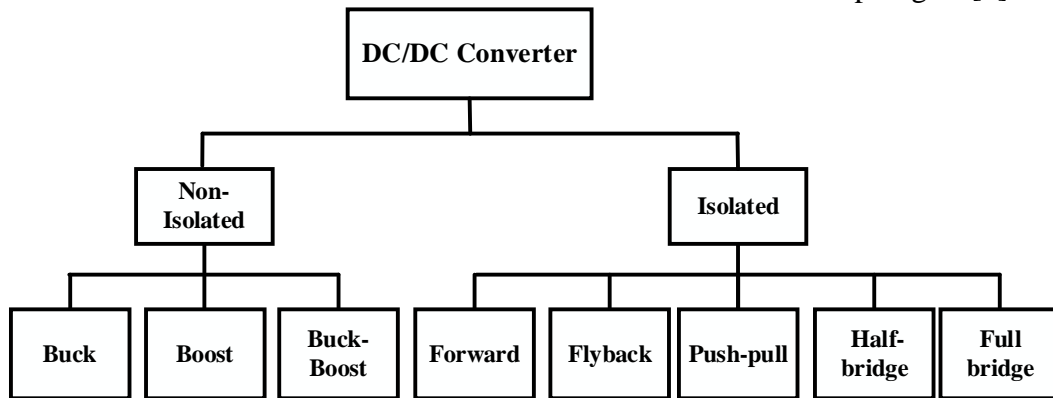

Fig. 2 The classification of DC-DC converter topologies [2]

This paper introduces the DC/DC converters that are essential for electric vehicles, analyses the circuits and operating principles of different DC/DC converter topologies, compares and analyses the features, advantages and disadvantages of the different types of converters, and discusses the problems that still exist in each DCDC converter as well as the ways to solve these problems.

2. Non-isolated DCDC Topologies

Non-isolated power module is a variety of different voltages (such as: 220VAC, 48VDC, 24VDC, 12VDC, etc.) directly into the electronic circuit, and then through the electronic components for lifting the voltage output, the input and output are directly connected through the electronic components, and the middle does not go through the transformer and other devices with isolation, so it is said that the non-isolated power module. Non-isolated DCDCs have a simple structure and the components are directly connected without additional energy loss, resulting in higher efficiency. The capacitance requirement on the boost side is higher. As a product that allows end users to use safely,

engineers in the design of power supply programmes generally consider the insulation of the system as well as the reliability of the isolation. In comparison, dc dc isolated power modules are a bit safer than non-isolated power modules. Non-isolated power supply module due to less energy lost in the magnetic-electric conversion of the transformer, so the efficiency is generally higher, most power supply manufacturers in the industry non-isolated power supply module efficiency can reach 91% or more. Non-isolated power supply module does not need to use a transformer for electrical isolation between input and output, so compared to dc dc power module, the same output power, the same output performance (such as output accuracy, load effect, dynamic response, etc.), non-isolated power module requires a smaller volume, lower cost, less difficult to design. If the design can be considered between the input and output is not isolated, compared to dc dc isolated power supply module, using non-isolated power supply module to design that can be said to be the engineer's first choice. DCDC non-isolated power modules have a wider output load range. non-isolated power supply module load range can be 30-84V. In this section we will introduce 3 different DCDC non-isolated topologies.

2.1. Buck Topology

The Buck circuit is a DC-DC converter based on the principle of inductive energy storage, which involves the basic principles of electromagnetic induction and electrical energy conversion in physics. The topology of a Buck-type converter is shown in Fig3. The Buck-type converter is also referred to as a step-down power supply topology [5]. When the switch S is on, the diode VD negative voltage is higher than the positive reverse bias cut-off, at this time the current through the inductor L to the capacitor and load power supply, while the inductor L stored energy. In the switch S off, inductance L in the stored energy can not be immediately released, resulting inductance current through the load, diode VD to form a continuous circuit, continue to supply power to the load. The diode is therefore called a continuity diode.

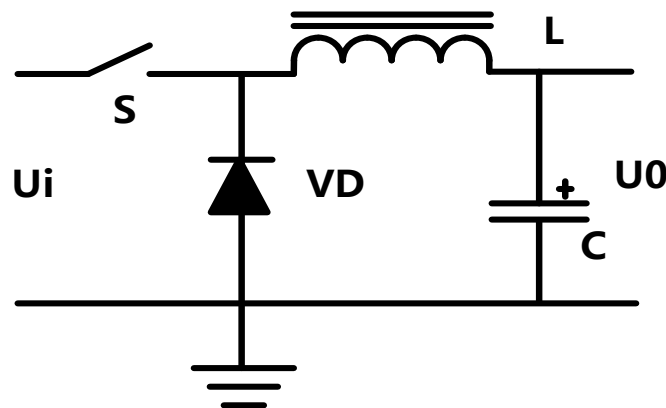

Fig. 3 Buck-type converter circuit diagram [5]

Buck circuit as a common step-down circuit, has a wide range of applications in the power supply field. Its main application scenarios include: regulated power supply for electronic devices, energy recovery systems, LED driver circuits. The characteristics of BUCK circuits mainly include high energy efficiency, stable output voltage, controllability and low cost. Overall, BUCK circuits have a wide range of application scenarios and better performance, and are able to provide stable power supply to the electronic devices and improve the efficiency of energy use.

2.2. Boost Topology

The basic topology of a boost converter is shown in Figure 4. This topology is called a boost power supply topology and is a DC-DC converter that can be boosted, where the voltage at the load side of the structure is higher than the voltage at the power supply side. The circuit of the boost converter must have diodes and transistors and an inductor. When switch S is on, the diode forward U is lower than the negative U reverse biased off, the power supply forms a path with the inductor, a current flows in the inductor L to store energy, and the load is powered by C. When the switch S is open, the

diode conducts forward, the power supply and the energy stored in the inductor L flow to the capacitor at the same time, and the load is powered by the capacitor [6].

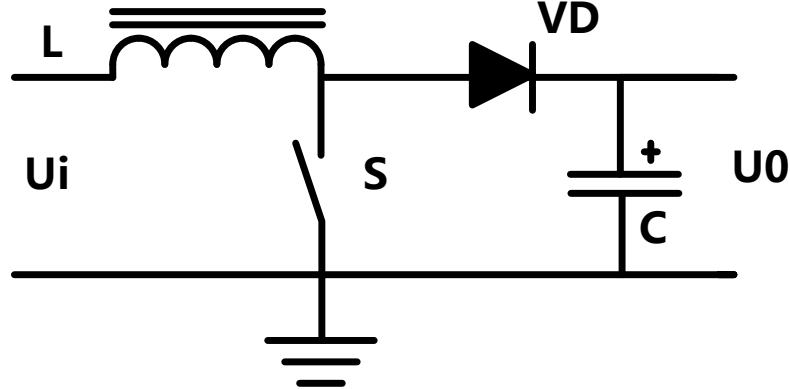

Fig. 4 Boost-type converter circuit diagram [6]

In many high voltage applications, space constraints prevent the desired voltage magnitude from being obtained by increasing the number of cells in series. Boost converters can increase the voltage without the need for a large series of batteries in series. Batteries and boost converters are often used in systems such as electric vehicles and lighting systems to act as a power supply.

Boost converters are often used as system power supplies in smaller devices such as portable lighting systems and light emitting diodes, which typically require 3.3 volts to emit light. White light emitting diodes typically require 3.3 volts to emit light, and a boost converter can be used to step up the 1.5 volts supplied by an alkaline battery and then supply power.

2.3. Buck-Boost Topology

The output voltage amplitude of the buck-boost topology can be greater than the incoming voltage or less than the input voltage. The basic topology of buck-boost converter is shown in Fig. 5. Therefore the structure is referred to as a boost type switching power supply topology. When the switch S is on, the diode negative voltage is higher than the positive voltage reverse bias cut-off, the power supply and the inductor to form a path, the inductor L stored energy. When the switch S off, the diode positive conduction, the inductor current will not be immediately released with the load [7], the diode to form a continuation circuit. However, at this time, the load voltage is opposite in polarity to the input voltage.

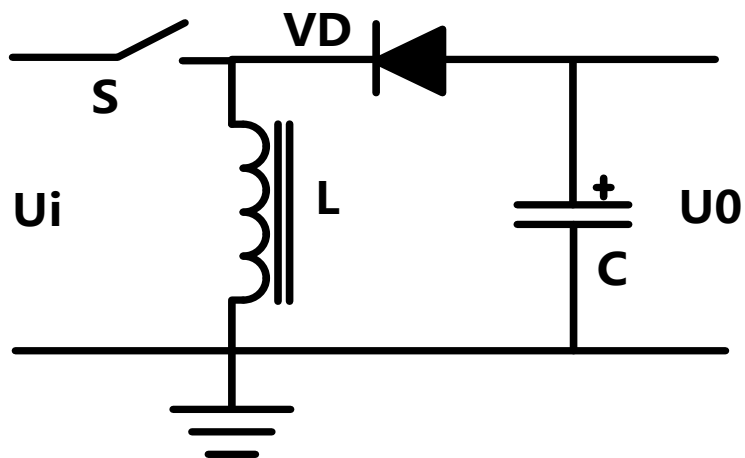

Fig. 5 Buck-Boost-type converter circuit diagram [7]

This Buck-Boost converter has many advantages, using this converter has a very low input-output voltage difference, very small internal losses, very small temperature drift, very high output voltage stability, very good load and linearity tuning ratio, a wide operating temperature range, a wide range of input voltages, and the peripheral circuits are very simple and extremely easy to use!

3. Isolated DCDC Topologies

Isolated DCDC power module is an isolated power supply is the use of a transformer will be a variety of different voltages (such as: 220VAC, 48VDC, 24VDC, 12VDC, etc.) through the transformer will be stepped down to the required voltage, and then used as a load power supply. Isolated DCDC converters add a high-frequency transformer to a non-isolated DCDC converter. Isolated bi-directional DCDC converter, more power switching, voltage ratio is large, with electrical isolation and other advantages. However, this topology has a high number of structural components and costs more than the other structures. The converter generates a large number of losses in the gray during operation, which can lead to the saturation of the isolation transformer core at low frequencies, and the losses can be further increased. Therefore, non-isolated bi-directional DCDC converters are more advantageous than isolated ones in electric vehicles. DCDC isolated power modules are generally below 88% efficiency, so the DCDC isolated power module heat will be relatively larger than the non-isolated power module. DCDC isolated power modules have a small output load range. DCDC isolated power supply module output load range of 30-42V. In this section we will introduce five different DCDC isolated topologies.

3.1. Forward Converter

Figure 6 illustrates the basic structure of the forward converter. The forward topology is obtained by adding a transformer between the switching tube and the diode of the buck converter. When the switch S is on, the supply voltage is added to the primary winding $W1$, and according to the relationship between $N1$ and $N2$ with the same name, the energy of the primary winding is transferred to the secondary winding $W2$, and $VD1$ is turned on, and the primary input energy is obtained by the inductance L and the capacitance C . When the switch S is off, the remaining energy in $W1$ is transferred to the secondary winding $W2$, and $VD1$ is turned on. On the contrary S disconnect, $W1$ in the remaining energy through the auxiliary winding $W3$ back to the power input, $VD1$ cutoff, secondary coil inductor L , diode $VD2$, load to form the on-off circuit.

In the forward converter need to pay special attention in the switch S off to the next cycle of the switch S on time to make the core of the remaining energy to be released, otherwise in the subsequent time, the value of the remaining energy continues to increase, and finally reached the core can withstand the limit value and saturation. Forward converter is widely used in 50W~400W due to simple circuit design, economy and convenience. However, since all coil currents on the transformer are all disconnected when the switching tube is turned off, in order to ensure that the core of the transformer does not become magnetically saturated, the addition of additional winding $W3$ serves as a core reset function.

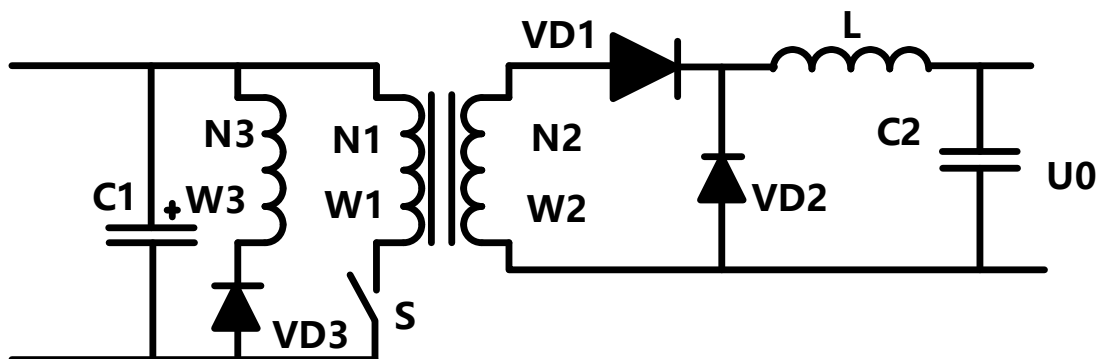

Fig. 6 Forward converter circuit diagram [8]

Forward switching power supply topology has the following characteristics: 1. no flux imbalance problem. 2. only 1 switching tube, relative to the push-pull topology power supply is cheaper and smaller. 3. multiple output power supply with the same as the push-pull topology: the voltage is based on the main output of the negative feedback, control switch on time to maintain voltage stability.

3.2. Flyback Topology

The basic topology of the flyback converter is shown in Fig. 7. By placing the high-frequency transformer in the place of the inductor in a Buck-Boost type converter you have a flyback circuit.

When the switch S on, the power supply voltage is added to both ends of the primary winding W1, according to the relationship between N1, N2 homonymous end of the winding W2 high potential at the lower end, diode VD1 does not conduct at this time. When the switch S off, the winding W2 high potential in the upper end, diode VD1 positive conduction, the load to obtain energy. Flyback converters are very easy to design, inexpensive, and are often used in low-power switching power supplies with multiple outputs.

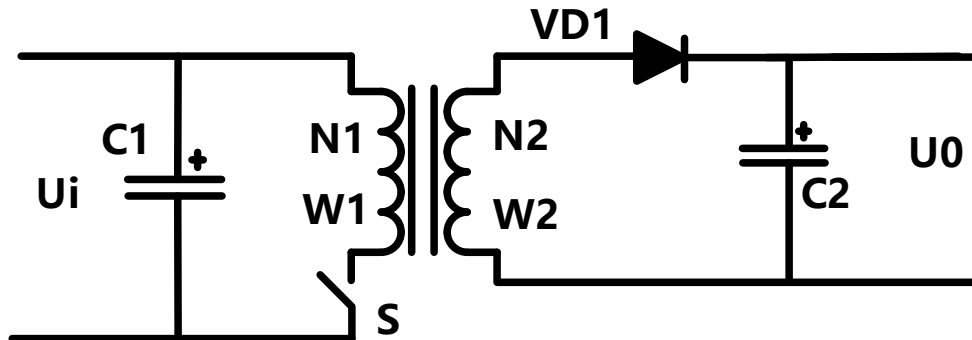

Fig. 7 Flyback converter circuit [8]

Advantages of the flyback converter topology: easy to apply, flexible and can be used in SMPS (switched mode power supply) designs. Flyback converter circuits have a wide range of applications: the circuits can be used for DC-DC power supplies, telecoms, LED lighting, Power over Ethernet (PoE), capacitor charging, battery charging, solar microinverters, AC-DC power supplies.

3.3. Push-pull Topology

The topology of a push-pull converter is shown in Fig. 8. The primary switching tubes S1 and S2 conduct alternately, the energy in the transformer core can be stored and released normally, and the energy is transferred from the primary terminal to the secondary terminal.

Turning switch S1 on and S2 off, the secondary winding diode VD1 conducts and the load is energized [8]. When S2 is on and S1 is off, the secondary winding diode VD2 conducts and the load still gets energy. When the switching tube S1, S2 are off, the inductor L through the diode VD1, VD2 and the load to form a path, according to the parallel shunt, the load current is only half through each diode, but at this time the switching tube are subjected to the voltage. So in order to ensure that the voltage stress on the switching tube is not too large, push-pull converter used in low-voltage high-current occasions have certain advantages.

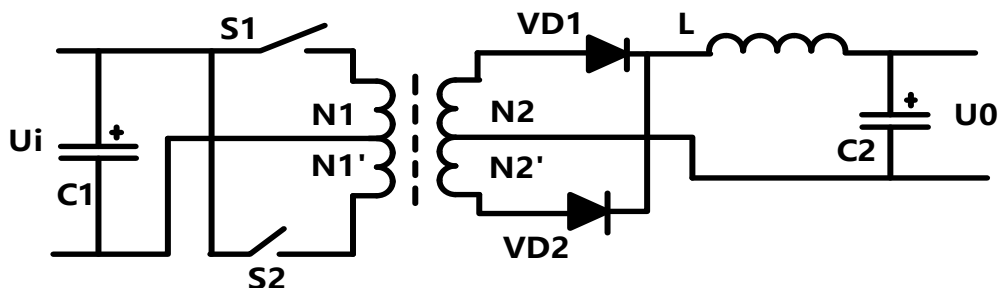

Fig. 8 Push-pull converter circuit diagram [8]

The push-pull topology is characterised by the following features: 1. High transformer core utilization (power is transmitted in both half-cycles), high output power up to several hundred W. 2. Fast current transient response (switching period is $T/2$, which corresponds to doubling of the operating frequency), good voltage output characteristics (compared to a half-bridge), and high voltage utilization. 3. Very good output voltage characteristics: both the output voltage pulsation

coefficient and the current pulsation coefficient are very small (doubling the operating frequency), only a very small value of the energy storage filter capacitor or energy storage filter inductor can get a voltage ripple and current ripple is very small output voltage. 4. high efficiency: push-pull switching power supply transformer leakage inductance and copper resistance loss is smaller; it belongs to the bipolar magnetization, the range of variation of the magnetic induction is twice as much as that of the unipolar magnetization, and its core permeability is higher, and the number of turns of the coil is less than half. 5. high output voltage characteristics: the output voltage is very good (compared with half-bridge), the output voltage characteristics are good (compared with half-bridge), and the voltage utilization is high. 6. The two switching tubes have a common ground, the drive circuit is simple (relative to the half-bridge, full-bridge switching, the following half-bridge/full-bridge topology when analysed).

3.4. Half-bridge Topology

Fig. 9 illustrates the circuit structure of a half-bridge converter. One bridge arm consists of two capacitors and the other bridge arm consists of two power switching tubes. When switch S1 is turned on and S2 is turned off, the N21 winding transfers energy to the load. When switch S1 is open and S2 is turned on, the N22 winding transfers energy towards the load, i.e. the secondary windings N21 and N22 release energy alternately.

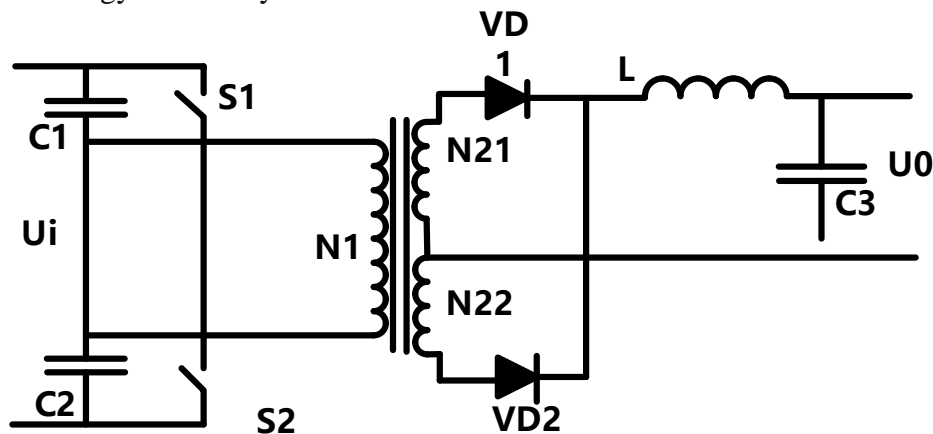

Fig. 9 Half-bridge converter diagram [8]

Capacitors C1 and C2 have the same capacitance value and type, so the voltage on each capacitor is the same. When the switch S1 is on and S2 is off, the diode VD1 is on and VD2 is off, and the N21 winding transfers energy to the load. When the switch S1 off, S2 on, diode VD2 conduction, VD cut-off, at this time the N22 winding can transfer energy to the load, that is, the secondary winding N21 and N22 alternately release energy.

Half-bridge DCDC converters are an extremely common topology for higher power converters. This structure uses switches (field effect tubes) driven in different stages to perform limiting of the pulse width to regulate the output voltage. This converter has good transformer core utilisation - transferring power in both half cycles. And the utilisation of the primary winding is superior to that of push-pull circuits. The structure is a full-wave topology, so the output ripple frequency is twice the transformer frequency. And the voltage applied to the FET is equal to the input voltage.

3.5. Full bridge Topology

The topology of the full bridge converter is shown in Fig. 10. This form of topology is characterised by hard-switching operation, low efficiency, voltage overshoot on the secondary side, wide range regulation, low output ripple, low ESR requirement for Co, and a typical efficiency of 92%. Four switching tubes form an H-bridge circuit and the transformer primary winding is connected to the load position of the bridge circuit. When switches S1 and S4 are on and S2 and S3 are off, the high potential of the primary winding is at the upper end. When switches S2 and S3 are on and S1 and S4 are off, the high potential of the primary winding is at the lower end. As a result, the currents

flowing in the primary winding in one cycle are in opposite directions, and there is no core saturation problem in the transformer, which makes it possible to make the efficiency and power density of the full-bridge converter very high. The secondary winding of the full-bridge converter has a centre tap and the output is full-wave rectified, making it suitable for high power applications.

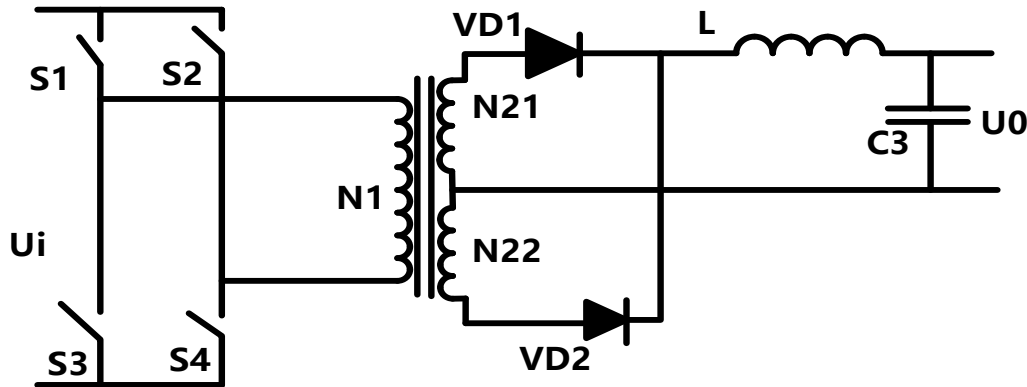

Fig. 10 Full bridge converter circuit diagram [9]

The full-bridge DCDC isolated topology type is a higher power converter and is the most commonly used topology in industry today. The converter switches (FETs) are driven in diagonal pairs for pulse width modulation (PWM) to regulate the output voltage, and the structure has good transformer core utilisation as with the half-bridge type - power is transferred in both half-cycles. For a given power, the primary current is half that in a half-bridge configuration.

4. Comparison of Five Isolated DCDC Topologies

Table 1 illustrates the advantages and disadvantages of the five isolated topologies as well as their different transmission powers and application areas.

Table 1. Comparison of advantages and disadvantages of five topologies

Topology type	Advantages	Disadvantages	transmission power	Areas of application
Forward converter	Simple, economical circuitry and easy to drive	Low transformer utilization	50W~400W	Various medium and small power supplies
Flyback converter	The circuit is very simple, very economical and easy to drive	Transformer utilization is low and power is difficult to make big	20W~150W	Low power, computer, consumer electronics equipment
Push-pull converter	High transformer utilization, high current, simple drive	Polarization problems	100W~500W	High power industrial power supply, electrolytic power supply
Half-bridge converter	High transformer utilization, fewer devices, economical	Straight through problem, unreliable, drive isolation	100W~5000W	Various industrial power supplies
Full bridge converter	Transformer utilization is high, power can be made larger	Complex circuits, uneconomical, straight through problems	500W~30kW	Low Input Voltage Power Supplies

A single-ended forward converter is a transformer that drives pulses in one direction through a single switching device. The advantages of this type of topology are the simplicity of the circuit, economy, simplicity of the drive, and transmission of power in the range of 50 W to 400 W. Since the transmission power of this type of converter is on the low side, the converter is suitable for a variety of medium and low power energy sources. This type of circuit also has a big problem, his

switch S has two states in its operation, sometimes it will be on and sometimes it will be off, when the switch is off, the pulse transformer will go into the "no load" state, which will continue to accumulate the magnetic energy preserved in it to the next cycle, and it will not stop until the inductor is saturated, which will lead to the switch and other devices to be burned out. Also the transformer utilisation of this circuit is very low. So it is generally not used in industry.

Flyback circuits are the opposite of forward circuits in that the two sides of the pulse transformer have a phase relationship that ensures that when the switching tube conducts and drives the primary side of the pulse transformer, the pay side of the transformer does not supply power to the load, i.e., the primary/pay side is staggered to turn on and off. The problem of accumulating magnetic energy in the pulse transformer can be easily solved, however, due to the presence of transformer leakage inductance, a voltage spike will be formed on the primary side, which may break through the switching device, and a circuit that provides protection is required. From the circuit schematic, the flyback is similar to the forward converter, the surface and the end of the transformer of the same name, but the circuit works differently. This type of circuit is somewhat of a very simple circuit, very economical, simple to drive, and its transmission power is generally between 20W and 150W. This transmission power is the smallest of the five different isolated topology circuit structures and therefore has a very limited field of application and is best used for low power, computer and consumer electronic equipment. The disadvantages of this converter are the low transformer utilisation and the difficulty in making the power larger.

Push-pull DCDC structure is a symmetrical, pulsed transformer with two coils on the initial side and two switching tubes that take turns to turn off the current in a process similar to a class B push-pull power amplifier in a linear amplifier circuit [7]. Push-pull structure of the transmission power of 100W to 500W, due to the high transmission power, the structure is commonly used in high-power industrial power supplies, electrolytic power supply. The main advantages of this structure are high core utilisation (relative to other circuits), high converter and power utilisation of the circuit (much higher than half-bridge circuits), high power output, low base level of both tubes, and the circuit is easy to build with this topology. The main drawbacks are low utilisation of the transformer winding, relatively high switching tube voltage requirements (at least twice the supply voltage), the circuit is prone to bias magnetism. Transformer core bias magnetisation is prone to occur during operation, leading to core saturation. This problem can result in switching power supply topologies that do not work stably for long periods of time.

The full-bridge circuit structure is characterised by the connection of four switches into a bridge structure, which transmits a power of 500W-30kW and is mainly used in low input voltage power supplies. This circuit has a number of advantages, with one-half as many primary windings as a push-pull circuit, the switching tube withstand voltage is reduced by half. The transformer utilisation is high and the power amplification can reach 30kW, which is widely used in the industrial field. However, due to the higher number of switching tubes used in this structure, and the parameters of this structure have better synchronisation, the drive circuit is complex and it is difficult to achieve synchronisation. Full-bridge converters are typically used in ultra-high power switching power supply circuits above 1KW. Moreover, the cost of this topology is high and uneconomical, which is difficult for many enterprises to afford.

Half-bridge DCDC circuits are similar in structure to the full-bridge type, except that two of the switching tubes are replaced by two large capacitors of equal value, reducing the number of switches. This type of circuit has a transmission power of 100W to 5000W and is suitable for a variety of industrial energy sources. This type of converter is widely used nowadays and it has more advantages compared to the above four structures. First of all, the circuit, with a certain degree of resistance to imbalance, the circuit symmetry requirements are not strict; In addition, due to with the adaptation of the power range is large, from dozens of watts to kilowatts can be, a variety of industrial energy can be used in the converter. At the same time the circuit in the switching tube withstand voltage requirements lower than other circuit structure; circuit cost is lower than the full-bridge circuit, the type of transformer utilisation is high, more efficient, the circuit requires fewer devices, less expense,

more suitable for large factories in bulk. However, the structure still has drawbacks, such as the existence of a straight-through problem in the circuit, and due to the simplicity of the circuit structure is not very reliable, may produce errors, drive isolation.

5. Future Prospects for DCDC Converters

After the last two parts of the DCDC topology comparison and analysis of various topologies, the study concluded that the current topology of the different DCDC converter is still in the application of the existence of a major problem, the main purpose of this part of the problem for the existence of the proposed solutions and future prospects.

The low transformer utilisation of forward and flyback topologies in practice is a difficult problem to solve, with the internal resistance of the power supply being a major factor limiting efficiency. DC-DC converters are capable of giving conversion efficiencies in excess of 95% under optimised conditions. However, this efficiency is limited by energy-consuming components, a major factor being the internal resistance of the power supply, which causes energy consumption that can reduce efficiency by 10% or more. A variety of energy-consuming components are located between the DC output and the load and become an integral part of the power supply: voltage source output impedance, wire resistance, and the resistance of contact resistors, PCB pads, series filters, series switches, hot-swap circuits, and so on. These factors can seriously affect system efficiency. The ideal effective solution to this limitation is to tend to set the supply voltage at a value as far away from the output voltage as possible when setting the characteristic parameters of the DC-DC converter in order to obtain the highest conversion efficiency. Using a higher supply voltage that substantially increases the voltage difference between input and output causes a unilateral reduction in the efficiency of the DC-DC converter, but the overall efficiency of the system is improved. For example, a system with input filters and long input lines can easily guarantee 95 per cent power supply efficiency without special consideration of line width and connector resistance [10].

Another expectation is that in the future it will be possible to select power modules capable of implementing full load currents power module and the weight size of the associated components. Designing lower cost, more compact systems using average power technology. Average power is a function of peak load requireme based on peak pulse levels. Although the possibility exists, a choice needs to be made between the nts and on-time ratios. Average power system designs utilise smaller DC-DC modules and appropriate PDN components to store large amounts of energy in order to keep the voltage within a certain range, an approach that optimises the power system for actual power requirements rather than over-designing the system for poor conditions.

In order to take full advantage of the functionality provided by parallel modules, future system designs should ensure that the array shares the load current equally. This will reduce the thermal stress on each module and thus maximise the full reliability of the array. The simplest way to do this is to use a sag equalisation mechanism that causes the output voltage to drop slightly as the load current increases and forces equalisation between modules. A more advanced approach is to add an active equalisation controller that monitors the independent output current of each module.

DC/DC converters for new energy vehicles face many hardware challenges, and the design of DCDC converters is difficult. For new energy vehicles with high safety requirements, the design of isolated DC/DC converters is very important, and the design challenges include thermal design, protection function design, EMC design, efficiency and manufacturability design. Challenges faced by DC/DC converter hardware for new energy vehicles include fewer domestic transformer suppliers, unstable supply of raw materials, and high cost of MOSFET components due to tight supply and demand in the market. Therefore, further technological advances are needed in the future to improve the efficiency of DCDC converters and to reduce board space.

6. Conclusion

In the context of the world's energy environment in recent years, more and more electric vehicles are being produced and put on the market. buck, boost, and buck-boost switching power supplies are basic switching non-isolated power supply topologies, but a significant disadvantage of their non-isolated topologies is that the input and output circuits must be jointly grounded, Boost, and buck-boost switching power supplies are basic switching non-isolated power supply topologies, but the non-isolated topologies of their A significant disadvantage is that the input and output circuits must be jointly grounded or they cannot be an effective switching power supply topology. Nevertheless, non-isolated topologies are often used in industrial applications due to their cheapness, simplicity, and availability for large-scale investments. Isolated converters are more accurate, but due to their complex structure, too many electronic components in the circuit, the efficiency of the process is not as high as that of non-isolated converters, including the problem of high cost, the inability to pass through the power supply, including push-pull converters are prone to bias magnetism phenomenon, which to a certain extent hinders the application of the converter in electric vehicles, so this paper discusses and analyses solutions to improve the efficiency of the DCDC converter efficiency and the future prospects of DCDC converters are discussed and analysed in this paper. DCDC power modules and non-isolated power modules have their own advantages, for different industries, different design requirements, the industry has always been these two products like a shadow. However, as the design level of DCDC power module manufacturers continue to improve, the volume as well as the cost of the DCDC isolated power module is constantly decreasing, so many customers are now giving priority to the isolated dc dc power module. The current DCDC converter still has problems and difficulties in use, hope that in the future as soon as possible to solve and improve these problems, improve the technical means, the isolated DCDC converter efficiency to maintain more than 95% and reduce the switching impact on the circuit, to achieve technological breakthroughs.

References

- [1] C. Roe, J. Meisel, A.P. Meliopoulos, F. Evangelos, T. Overbye. Power System Level Impacts of PHEVs. in 2009 42nd Hawaii International Conference on System Science, 2009.
- [2] Yu Du, Xiaohu Zhou, Sanzhong Bai, Srdjan Lukic and Alex Huang. Review of Non-isolated Bi-directional DC-DC Converters for Plug-in Hybrid Electric Vehicle Charge Station Application at Municipal Parking Decks. FREEDM Systems Center, 2021
- [3] Mohammadzadeh Shahir, Farzad; Babaei, Ebrahim; Sabahi, Mehran; Laali, Sara. A new DC-DC converter based on voltage-lift technique. International transactions on electrical energy systems, 2016, 26 (6): 1260-1286
- [4] Ji, Kai; Chen, Tingyang; Long, Wenfeng; He, Jinping. Research on Topology and Modulation Control Method of a Novel Three-Level Current-Fed DCDC Converter. IOP conference series. Materials Science and Engineering, 2019, 612 (4): 42086
- [5] Chakraborty, S., Vu, H. N., Hasan, M. M., Tran, D. D., Baghdadi, M. E., & Hegazy, O... Dc-dc converter topologies for electric vehicles, plug-in hybrid electric vehicles and fast charging stations: state of the art and future trends. Energies, 2019, 12(8), 1569-
- [6] Cao, Guoen; Zhang, Jin; Wang, Yibo. Non-isolated Ultrahigh Boost Ratio DCDC Converter with Coupled Inductor and Charge Pump. 2021 IEEE 1st International Power Electronics and Application Symposium (PEAS), 2021, p.1-4
- [7] Upadhyaya, Shreyansh; Rana, Kailash; Taneja, Manas; Joshi, Dheeraj. Modelling and Control of Non-Isolated Multiport DC/DC Converter, 2020 First IEEE International Conference on Measurement, Instrumentation, Control and Automation (ICMICA), 2020, p.1-5
- [8] Mohammad Faisal Akhtar, Siti Rohani S. Raihan, Nasrudin Abd Rahim, Mohammad Nishat Akhtar, and Elmi Abu Bakar. Recent Developments in DC-DC Converter Topologies for Light Electric Vehicle Charging: A Critical Review. MDPI, 2023

- [9] Shi, Weichao; Zhang, Haiyan. Research on Optimal Control of Dual Active Full-Bridge DCDC Converters. Journal of physics. Conference series, 2022, 2383 (1): 012063
- [10] Breton, Valentin; Bigot, Emile; Despesse, Ghislain; Costa, Francois. A New isolated Topology of DC-DC Converter Based on Piezoelectric Resonators. IEEE transactions on power electronics, 2023, 38 (8): 10012-10025