

Technology And Application Outlook of Integrated Circuits Under the Internet of Things

Shengjiang Heng *

Department of Information and Electrical Engineering, China Agricultural University, Beijing, China

* Corresponding Author Email: shengjiangedu@cau.edu.cn

Abstract. The rapid development of the Internet of Things (IoT) has injected new vitality into the development of integrated circuits (ICs), however, IoT devices have a variety of characteristics that are different from those of traditional electrical equipment, such as complex application environments, small installation space, energy supply difficulties, etc., which also puts forward new requirements for the development of ICs, based on which, this paper presents a certain analysis of the recent innovations in the field of integrated circuits (ICs) in the field of Internet of Things (IoT), which are important for solving the problems of IoT communication, energy supply, circuit design, security and confidentiality, etc. At the same time, the author also puts forward some of his own views on solving related problems. All in all, the article analyzes the problems and possible solutions of ICs in the field of Internet of Things and looks forward to the future development prospects. This is of some significance for the further development of integrated circuits in the field of Internet of Things.

Keywords: Internet of Things, circuit design, security, energy supply.

1. Introduction

With the progress of the times and the development of Internet technology, the Internet of Things has gradually become a reality from a vision, and gradually into thousands of households. The internet of Things will be a large number of intelligent computing objects and connect the physical and cyber-Earth of the Internet smoothly connected, so that the various devices can exchange information between the realization of remote control. But the realization of this remote interaction requires a large number of information transmission and adapt to the complexity and variability of the application environment, puts forward a higher demand for circuits, the Internet of Things, the further development of the further development of the integrated circuit calls for further innovation [1].

This article highlights recent innovations in the field of integrated circuits related to the Internet of Things (IoT). Under the premise of laying the foundation of IoT and ICs in advance, the article briefly introduces the recent innovations of ICs from four aspects, namely, circuit design, energy supply, communication, and security, which have provided more compact and flexible circuit design, provided new ideas for solving the problem of energy supply in special circumstances, and contributed to sensitive communication and security of IoT, and in the end, the author puts forward his own innovative views on the development of ICs in the field of IoT and makes his own outlook on its application prospect. Finally, the authors present a little innovative view of their own on the development of integrated circuits in the field of IoT and make their own outlook on the prospects of their application. This will be conducive to the further development and healthy growth of the Internet of Things.

2. Theoretical definition of integrated circuits in the context of the Internet of Things

2.1. Basic Theory of Internet of Things (IoT)

Although the term IoT has been widely mentioned for a long time, there is still no standard academic definition of IoT as an emerging thing. Despite this, the general direction and goal of defining IoT is similar in the literature of various researchers. In this research literature, IoT is broadly

defined as a network of uniquely identifiable endpoints or "things" that capture and share data. Its widely recognized architectural model consists of three components: a physical sensing layer that senses the physical environment and human social life; a network layer that transforms and processes data from the sensed environment; and an application layer that provides context-aware intelligent services in a pervasive manner. Some scholars, however, argue that the third component is the network layer, which is the network that provides the context-aware intelligent services. (However, some scholars believe that the third application layer should be split into the platform tool layer and application service layer, i.e., a four-layer architecture, thus making the relevant software classification more refined. On the perception layer, since each device accessing the IoT needs an independent IP address, the demand for IP addresses is extremely high, and so the IPv6 protocol, which has more IP addresses, is mainly used. In terms of data transmission at the network layer, IoT is based on wireless transmission to achieve energy saving and high efficiency. The main means of short distance transmission are Bluetooth, Wi-Fi and ZigBee, etc., medium distance is based on 5G, and the main technologies for long distance transmission are low power wide area network and very small aperture terminal. In some special environments, wired transmission based on Ethernet and power grids are also used. IoT has a wide range of application prospects in various fields, such as in industry IoT is regarded as the key to open up the industry 4.0 era, and in healthcare IoT has a huge role to play in promoting remote diagnosis, and so on [2,3]. A brief concept map on IoT is shown in figure 1.



Fig. 1 A brief concept map on IoT (Photo/Picture credit: Original)

2.2. Basic Theory of Integrated Circuits

Compared to IoT, IC is a relatively mature technology, which is a kind of small circuit assembled by semiconductor components and other passive components on the corresponding circuit boards, gradually replacing the traditional transistor circuits due to its small size, low cost, and better performance than traditional large circuits, and the well-known personal computer is the masterpiece of this technology.

The most basic elements of integrated circuits are the P-type and N-type semiconductors and the PN section formed by them, on top of which are transistors made of various semiconductors, mainly bipolar transistors that amplify current and field effect transistors that control current. The field effect transistors are combined to form logic gates such as and gates, or gates, and same-or gates, which are combined to form complex logic circuits that perform various calculations and functions. In the emerging field of Internet of Things (IoT), as IoT devices have higher requirements on operating environment, circuit size, energy consumption, etc., compared with traditional electrical devices, ICs are also keeping pace with the times, and have made great progress in information security, energy saving and performance optimization [4]. However, with the further development of the Internet,

traditional IC devices have been exposed to problems such as easy privacy leakage, poor compatibility between devices, and high energy consumption of sensors, which cannot adapt to the flexible and changeable application environment. The solution of these problems is extremely critical to the further development of IoT and is the direction that scholars in this field are working towards. Happily, there are now a variety of innovative IC designs in this field, which all alleviate some of the current problems in one way or another, and the following will introduce some innovative designs of integrated circuits in the field of Internet in recent years. The PN section is shown in figure 2.

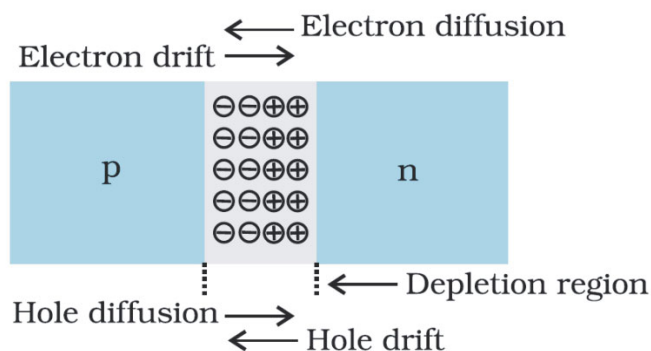

Fig. 2 The PN section (Photo/Picture credit: Original)

3. Advanced technology creation

3.1. Smaller and more flexible IC design optimization

The continuous development of the Internet of Things (IoT) has put forward higher requirements for the packaging and miniaturization of integrated circuits, and in the present time, some scholars have invented a new CMOS heterogeneous integration and packaging technique, which has contributed to the solution of this problem. The method uses a CMOS-enabled MD-IC, wafers are interconnected in a manner similar to a 3D jigsaw puzzle, with the required sensors and transmission antennas installed on the outside, microprocessors and miniature lithium-ion batteries integrated on the inside, and Indium Gallium Zinc Oxide (IGZO) thin-film transistors (TFTs) also fabricated on the silicon surface for sensing applications [5]. The interconnects are coated with 500 nm silver using electron beam evaporation. Six layers of PDMS are used to encapsulate the interconnects and isolate the internal components from the external environment and enhance the mechanical robustness of the system. In testing, this packaging technology not only achieves high performance, low power consumption and multifunctionality in a small-sized package, but also withstands high temperatures (200 degrees Celsius to 300 degrees Celsius) and high humidity (~60%), and is able to adapt to a wide range of different application environments, which is important for the further development of the Internet of Things (IoT). further development. The Schematic of the integration process is shown in figure 3.

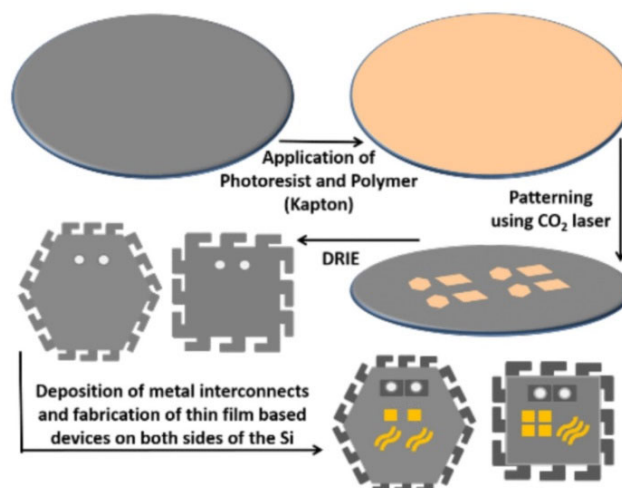

Fig. 3 Schematic of the integration process of the MD-IC (Photo/Picture credit: Original)

3.2. Innovative design in communications

Communication between components is a key aspect of the IoT, and recent years have seen some innovative designs in IoT communication as well. Transceiver is an important part of IoT communication architecture, plays an extremely important role in the exchange of information between the various components of IoT, in which the ultra-low-power frequency synthesizer is a key component of this component, which has extremely strict requirements on power consumption and cost, the traditional ring oscillator chip is smaller, but in the case of the same power consumption is greater than the LC circuit phase noise, which is not favorable to the Its application in IoT, in recent years a team of scholars has developed a novel technique to solve this problem, firstly, the phase discriminator (PD) firstly measures the accumulated phase error and applies the injected pulse to the oscillator at the next edge of the RF clock[6]. Second, foreground SPO calibration is proposed to effectively reduce the reference spuriousness; finally, a dual-path injection technique is introduced to significantly improve the NBW and in-band phase noise of IL-DPLL. At the implementation level, based on the smaller IoT data packets, the team uses fast foreground SPO calibration to evade multiple locking of the DPLL and thus reduce energy consumption, and at the injection stage the team cautiously chooses an injection pulse width selection of ~ 100 ps and introduces an auxiliary injection path to minimize distortion and reduce noise, thus improving component reliability. With this technique, the team realized the coexistence of low power consumption and high quality FOM, opening the way for the development of smaller, lighter, and more flexible transceivers.

Satellite as an important means of communication also plays a great role in the communication segment of IoT, however, traditional integrated circuits appear to be extremely expensive in terms of satellites, which seriously restricts their utilization in the field of IoT. In recent years, a research team has proposed a radiation-enhanced integrated circuit design method to reduce the cost of satellite applications in the field of IoT. By selecting a suitable total ionization metrology and optimizing the CMOS design, the team explored a RHBD design with better TID immunity, which achieves radiation hardening, while realizing low cost and intelligence, which is expected to reduce the cost of satellites used in IoT. The RHBD voltage ref Schematic and the Schematic of the proposed ADC is shown in figure 4 and 5 [7].

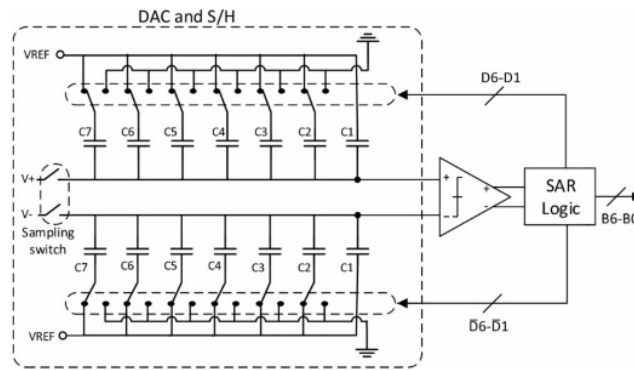

Fig. 4 RHBD voltage ref Schematic [7]

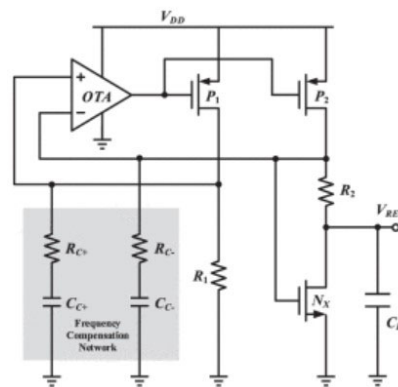

Fig. 5 Schematic of the proposed ADC [7]

In the application environment of the Internet of Things, transceivers usually cannot be retrofitted with large power supply devices like traditional devices, which makes the transceivers in this application environment have more stringent requirements for energy saving, and in recent years, a team has developed an ultra-low-power CMOS-based RF receiver, which can effectively satisfy this demand. In the low-noise amplifier link, the team used the common gate architecture to reduce energy consumption, in other parts also in a controlled range to increase a little noise at the expense of low energy consumption, and ultimately make the receiver to meet the use of the performance needs of the premise of the lowest possible power consumption [8].

3.3. New designs on IoT security

Although the development of the Internet of Things makes people's lives more and more convenient, but with its further development, security and privacy issues are also increasingly prominent, pervasive hacker groups and the Internet lawless elements can always find a variety of loopholes to invade the user's system, with the emergence of a variety of Internet viruses and loopholes in recent years, the lawless elements of the network attack even more like a fish out of water, which is undoubtedly on the Internet of Things puts forward a higher level of security requirements. This undoubtedly puts forward higher requirements for the security of the Internet of Things (IoT). Compared with traditional Internet attacks, IoT attacks have two major characteristics of destructive and difficult defense, different from the Internet, IoT and people's clothing, food, housing and transportation have a direct physical connection, if the worst Internet attacks are only the loss of property and privacy, IoT attacks will seriously affect people's normal life and even kill people. At the same time, IoT is constrained by its wide range of application environments, small space and limited energy supply, which makes it not only difficult to have a unified means of defense like traditional Internet devices, but also relatively weaker resistance to attacks. Therefore, there is an urgent need for security protection strategies applicable to the Internet of Things (IoT), fortunately, in recent years, a team of scholars has studied a variety of defense measures applicable to the Internet of Things (IoT), the following briefly introduced one or two.

Although wireless 3D integrated circuits have the advantages of low cost and easier design, they are more susceptible to electromagnetic detection side channel attacks, which is not conducive to security because they realize data transmission between layers through electromagnetic induction. A team of scholars has created a novel encryption method that effectively prevents eavesdropping attacks by attackers targeting this weakness. Given the limited resources available in the IoT environment, instead of traditional secret key encryption (because of the risk of theft by attackers) the team used a physical unclonable feature to ensure security, which utilizes manufacturing process variations to generate a unique and device-specific identity for the physical system that corresponds to a specific instance of a device rather than a generic identity for a class of devices, making the encryption unclonable and thus reducing the chance that an attacker will be able to eavesdrop on it, thus reducing the chance that an attacker will be able to eavesdrop on it. cloning, thus reducing the possibility of an attacker cracking the encryption or predicting the secret key through other similar IoT devices [9]. At the same time, this encryption method does not require expensive and bulky encryption hardware, and has the advantages of low energy consumption, lightweight and flexible, and does not require huge computational resources, which is especially suitable for IoT devices with limited computational resources and has a wide range of application prospects. Another research team has realized a low-power (at 0.5V voltage) physical unclonable function by ring oscillator collapse, which broadens the application of this method. Some teams have also started with capacitive digital-to-analog converters to prevent attackers from determining the logic value of each bit in a conversion cycle by controlling each capacitor in the differential DAC separately to achieve spatial and temporal randomization. Since each SAR logic state ends only when all capacitors have converted or reached their maximum count therefore the duration of the state is variable, eliminating the possibility of an attacker determining a positional leak at a specific time [10]. Also, this approach does not result in significant degradation of DAC performance. It has also been argued that the decentralized and decentralized nature of another emerging technology, blockchain, can be leveraged to allow the combination of blockchain and IoT to reduce single point of error while enhancing cryptographic capabilities [11]. The Proposed inductance PUF is shown in figure 6.

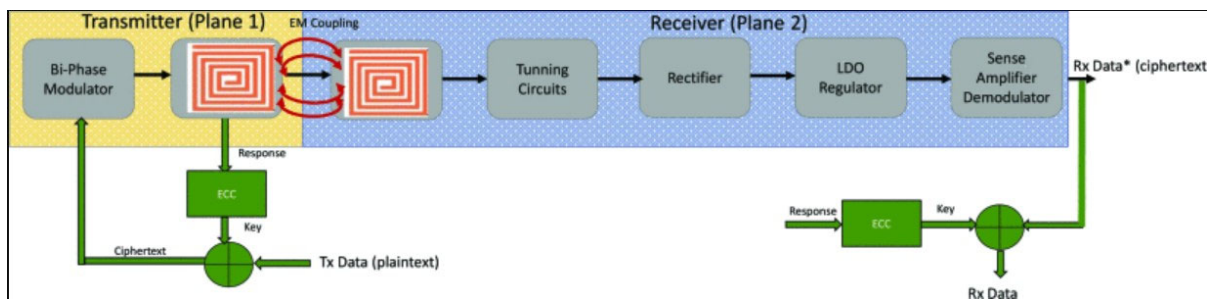

Fig. 6 Proposed inductance PUF for wireless data encryption [10]

3.4. Innovations in energy supply

As a sophisticated electrical system, energy supply is also very important to the IoT system, but IoT is widely distributed due to the devices. The use of the environment is variable, resulting in traditional power supply methods and energy sources are difficult to apply to the flexible IoT. And the sensors and because of the frequent use, installation space is narrow, need to accept a variety of extreme environmental tests (such as high temperature, high humidity, severe dryness, etc.) has become a major problem of the Internet of Things energy supply, in recent years, a research team believes that compared with solar energy, wind energy and thermal energy, microwave band electromagnetic (EM) energy is a more stable, suitable for remote areas and complex environments under the power supply of the energy source, and Based on wireless power transmission, a set of power supply equipment was developed to receive EM energy for sensors through a small rectifier array, and based on a small polarization-insensitive rectifier super surface technology, the whole system was miniaturized and simplified, and the versatility of the design was enhanced to make it

capable of being applied to different IoT devices[8]. The Structure of rectifying meta surface unit is shown in figure 7.

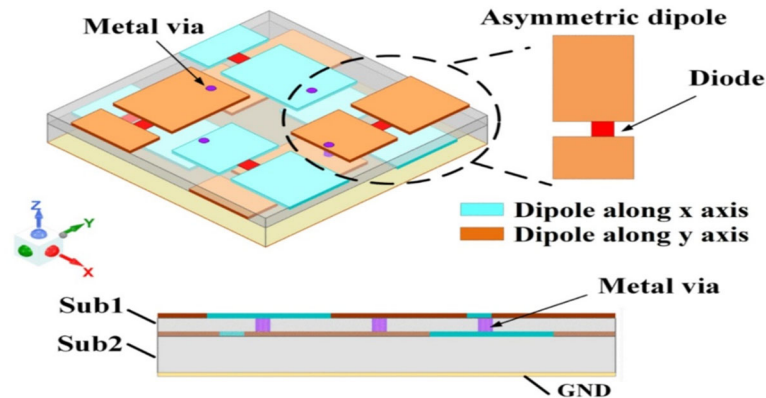

Fig. 7 Structure of rectifying meta surface unit [8]

4. Innovative design and application prospects

Overall, the booming development of the Internet of Things (IoT) has injected new vitality into the development of integrated circuits (ICs), but the application environment of IoT is very different from that of traditional applications. IoT devices not only have limited installation space, but also must withstand a variety of emergencies and adverse environmental conditions, which makes it difficult for traditional IC devices to play a good role in IoT environments, and new devices adapted to such environments are urgently needed to be developed. There is an urgent need to develop new devices that are suitable for this environment. Although many scholars have developed innovative designs and solutions for energy supply, safety, and other issues, there are still some problems that need to be solved, including adaptability. In the following, the author briefly discusses his innovative ideas and possible applications.

The rapid development of the Internet of Things (IoT) has led many related companies to enter the market, however, this has also led to poor generalization among IoT devices. Competition between companies and the constraints of production conditions lead to the products of different companies cannot be common, to the home of the common smart refrigerator and smart air conditioning, for example, usually only corresponding to the company's operating platform, or even corresponding to the company's smartphone to operate the corresponding device, which undoubtedly caused great inconvenience to the user, but also restricts the further development of the Internet of Things, in view of the situation, the author believes that it is necessary to Development of a set of universal communication equipment, this set of equipment in the Internet of Things as a translator, a variety of control terminals issued by the control signals in the device is converted into a common communication language, and then translated into the language output of the corresponding device, the information collected by the sensor is also input to the communication terminals in this way, and the regular manufacturers to give the consumer's console access to this "translation" access. The regular manufacturers give consumers access to this "translation" at the control side. This not only strengthens the universality of IoT devices, so that consumers do not have to repeatedly switch between different operating platforms, but also curbs the use of pirated and counterfeit products and promotes the healthy development of the IoT industry.

5. Conclusion

In conclusion, the rapid development of the Internet of Things (IoT) provides opportunities for the development of the integrated circuit industry, but its complex working environment, small working space, and insufficient computational power puts forward higher requirements for integrated circuits, the new circuit design and the new type of energy supply design in the paper provide new ideas for

solving the problem of the IoT devices operating in remote areas and harsh environments, and the physical non-cloneable is used as a new type of Physical non-cloning is also widely used as a new type of secrecy method. However, with the emergence of Internet viruses and vulnerabilities, and the continuous deterioration of the network security ecosystem, the continued development of IoT requires stronger security. At the same time, the incompatibility between the hardware of various manufacturers and the lack of production capacity of new integrated circuits are also constraining the further development of the Internet of Things. In the future, IoT should continue to promote integrated circuit innovation, gradually forming its own set of new integrated circuit industry, while strengthening the compatible design and improve the user experience. The security measures of IoT should also be upgraded to cope with possible future attacks. In conclusion, the future of the combination of IoT and IC is challenging and bright, and the future of the combination of IoT and IC requires the continuous efforts of scholars.

References

- [1] J. C. Talwana and H. J. Hua, 2016 IEEE International Conference on Internet of Things (iThings) and IEEE Green Computing and Communications (GreenCom) and IEEE Cyber, Physical and Social Computing (CPSCom) and IEEE Smart Data (SmartData), Chengdu, China, 2016.
- [2] J. Leng, Z. Lin and P. Wang, 2020 IEEE/ACM Fifth International Conference on Internet-of-Things Design and Implementation (IoTDI), Sydney, NSW, Australia, 2020
- [3] H. Li and X. Wang, 2020 International Conference on Computer Network, Electronic and Automation (ICCNEA), Xi'an, China, 2020.
- [4] M. -h. Chi, D. Xiao and R. Chang, 2018 14th IEEE International Conference on Solid-State and Integrated Circuit Technology (ICSICT), Qingdao, China, 2018
- [5] N. El-Atab, S. F. Shaikh, S. Khan, J. Yun and M. M. Hussain, 2019 IEEE SOI-3D-Subthreshold Microelectronics Technology Unified Conference (S3S), San Jose, CA, USA, 2019.
- [6] S. A. Abdelbadie, A. A. Mikhael, M. M. Helmy, B. A. Elgharabawy and A. N. Mohieldin, 2018 7th International Conference on Modern Circuits and Systems Technologies (MOCASST), Thessaloniki, Greece, 2018.
- [7] W. Shu, J. Jiang, K. S. Chong and J. Chang, 2018 IEEE 23rd International Conference on Digital Signal Processing (DSP), Shanghai, China, 2018
- [8] F. Yu, X. -X. Yang, Z. Yi and S. Gao, in IEEE Antennas and Wireless Propagation Letters, vol. 22, no. 7, pp. 1637-1641, July 2023
- [9] J. Dofe and W. Danesh, 2021 IEEE 34th International System-on-Chip Conference (SOCC), Las Vegas, NV, USA, 2021
- [10] A. G. Mustafaev and A. Y. Buchaev, 2020 International Conference on Information Technologies (InfoTech), Varna, Bulgaria, 2020.
- [11] K. P. Satamraju and B. Malarkodi, 2019 TEQIP III Sponsored International Conference on Microwave Integrated Circuits, Photonics and Wireless Networks (IMICPW), Tiruchirappalli, India, 2019