

# Design Of Communication Unit for Mine Explosion-Proof Reversible Vacuum Electromagnetic Starter

Tongzhe Li<sup>1, 2, 3</sup>, Hongkui Zhang<sup>1, 2, 3, \*</sup>

<sup>1</sup> Fushun CCTEG Inspection Center Co. Ltd, Fushun Liaoning, China

<sup>2</sup> CCTEG Shenyang Research Institute, Fushun Liaoning, China

<sup>3</sup> State Key Laboratory of Coal Mine Safety Technology, Fushun Liaoning, China

\* Corresponding Author Email: 18940021505@126.com

**Abstract.** Mine explosion-proof reversible vacuum electromagnetic starter is the main electrical equipment in underground coal mine. On the basis of analyzing the situation of coal mine safety production, the characteristics of mine explosion-proof reversible vacuum electromagnetic starter and CAN bus technology, the digital signal processor (DSP) is used as the core to design the communication unit of mine explosion-proof reversible vacuum electromagnetic starter, and the real-time transmission of data between the DSP and the upper computer is realized through CAN communication technology.

**Keywords:** eCAN bus; coal mine; starter; communication system.

## 1. Introduction

In recent years, there is a continuous improvement in the situation of coal mine safety production in China, however, the complex mining environment and the increase in mining intensity have constrained the healthy development of the coal industry for a long time. When the underground gas and other flammable gas concentration is too high, meet the spark will produce an explosion, which is a direct threat to the coal mine safety production work. Mine explosion-proof electromagnetic starter is applied to directly or remotely start, stop or forward and reverse control three-phase asynchronous motors, and at the same time has the protection function of motor overload, short circuit and leakage faults, etc. It is widely applied in coal mine ventilators, scraper conveyors, winches and belt conveyors and other electrical equipment. The research of mine explosion-proof electromagnetic starter communication system can send the running status of the motor to the upper computer in real time, which is of great significance for improving the stability of the underground equipment and guaranteeing the smooth implementation of safe production, and at the same time accelerating the construction pace of the intelligent mine and speeding up the rapid realization of the modernized coal mine technology.

Mine explosion-proof reversible vacuum electromagnetic starter is mainly used for controlling the direct start, stop and forward and reverse running of mining motors, as well as detecting and protecting motor faults. Mine explosion-proof reversible vacuum electromagnetic starter adopts the structure of quick-opening door, which is simple and reasonable and easy to operate. It consists of explosion-proof shell and double AC vacuum contactors, isolation switches, control buttons, control transformer, comprehensive protector, capacitance resistance protection device and other components installed in the shell, suitable for use in underground coal mines and its surrounding medium in methane, coal dust and other hazardous mixtures of gases in the environment, in AC 50Hz, voltage up to 1140V or less, and in the environment with the following voltage. Voltage up to 1140V, rated current up to 400A in the power supply system. Mine explosion-proof reversible vacuum electromagnetic starter can realize remote starting and stopping of loads, with overload, phase break, short circuit, leakage lock detection and other protection functions. Mine explosion-proof reversible vacuum electromagnetic starter is shown in Figure 1.



**Fig. 1** Mine explosion-proof reversible vacuum electromagnetic starter

## 2. CAN bus Technology

Fieldbus technology is one of the hotspots in the field of automation, providing strong technical support for real-time and reliable communication between nodes of a distributed control system. CAN is the abbreviation of Control Area Network (CAN), which is a kind of serial communication bus supporting distributed control or real-time communication. CAN bus technology was firstly developed to meet the needs of automotive electronics technology, which is one of the most widely used fieldbus. In recent years, CAN bus has been widely used in automotive system communication, power grid monitoring, electrical equipment testing and communication and other technical fields due to its simple structure, high reliability, flexibility and good error detection capability.

CAN bus adopts multi-master serial communication protocol, which can effectively support distributed real-time control, and the communication rate can be up to 1Mb/s. The data frame of CAN bus is composed of several bytes (up to 8 bytes), which increases the response time of the bus for new data frames. Each message of CAN bus has its own marker when transmitting data to identify the node of different messages on the bus, which ensures that there is no delay in transmission when a bus conflict occurs.

## 3. Design of communication system

Mine explosion-proof reversible vacuum electromagnetic starter communication unit sends the system information collected by DSP to the host computer through CAN communication technology to realize the real-time communication between DSP control system and the host computer. The communication system adopts the modular design idea, first of all, take DSP as the core, combined with the CAN bus communication converter SN65HVD23X to design the hardware circuit of the communication system; and then compiles and debugs the software program of the communication system which is written in assembly language, C language or other high-level languages in the DSP software compilation environment CCS3.3, and then finally burns the debugged program into the hardware circuit; Finally, the debugged program is burned into the hardware circuit to complete the overall debugging and verification of the communication system.

### 3.1. Design of hardware circuits

The logic electrical level of the eCAN bus controller of DSP adopts the LVTTTL method. Because the voltage of the LVTTTL method is mostly low voltage, such as 3.3V, 2.5V, etc., it not only reduces the power consumption but also reduces the size of the circuit. In order to realize the electrical level matching between eCAN module and CAN physical bus, SN65HVD230 is selected as the converter, which has the characteristics of differential transceiver capability, strong anti-jamming ability and fast transceiver rate, etc., and better meets the information transmission requirements of the communication system of the mine explosion-proof electromagnetic starter. The 120Ω resistors R1 and R2 are connected at the end of the bus for impedance matching of the transmission line to increase the anti-jamming capability of the communication system, and the connection circuit between the CAN bus and the DSP is shown in Figure 2.

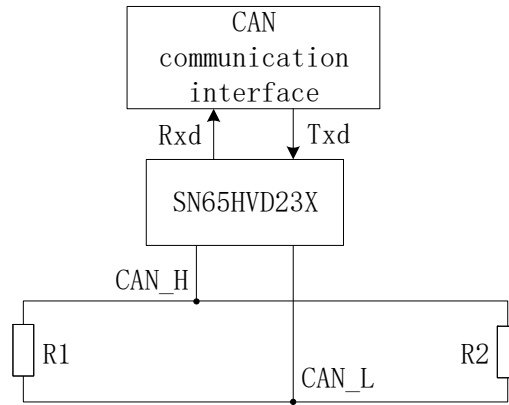

**Fig. 2** Circuit diagram of eCAN communication module

**3.2. Software Programming**

Mine explosion-proof reversible vacuum electromagnetic starter communication unit in the use of CAN communication needs to be initialized before the operation, the specific steps are: enable the CAN module clock; set CANTX and CANRX as the communication pin; reset the CCR bit and CCE position 1, allowing the user to configure the bit time configuration register; use the appropriate values for CANBTC configuration, confirm that the TSEG1 and TSEG2 are not equal to 0; program the receive mask register (standard CAN mode); program the main control register; clear all bits of the MSGCTRLn register for initialization; check whether CCE is cleared to zero, and if it is cleared, it indicates that the configuration of the CAN module is complete. When the eCAN module receives the message, the corresponding flag bit of the register (CANRMP) will be raised, and the corresponding interrupt flag bit will generate an interrupt, and then the CPU can read the data received in the data register of the receiving mailbox. The eCAN module sends the message process mainly includes several steps such as the system initialization, mailbox initialization, sending the transmission settings and waiting for the transmission response, etc., and the specific sending process is shown in Fig. 3.

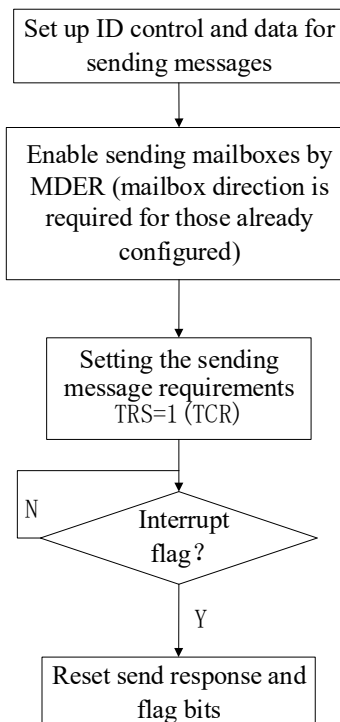

**Fig 3.** Flowchart of CAN communication message sending

## 4. Conclusion

Mine explosion-proof reversible vacuum electromagnetic starter communication unit applies the CAN communication technology of DSP to the data transmission technology of underground coal mine, which can send the motor status information collected by DSP to the host computer in real time, and the host computer will send the action instruction to DSP through CAN bus after calculating and analyzing the data, so as to realize the monitoring and protection of the running status of the coal mine motor, and improve the stability and safety of the operation of the underground motor.

## Acknowledgements

The authors gratefully acknowledge the financial support from Technical Support Project of the State Administration for Market Regulation (2023YJ12) and Technology Project of the Liaoning Market Supervision Administration (2023JS007) funds.

## References

- [1] Luo Kaichuan, Shi Wei, Zhang Zhouyun. Method of Loss Separation of Permanent Magnet Synchronous Motor Based on Temperature Experiment. *Transactions of China Electrotechnical Society*, 2022, 37(16): 4060-4073.
- [2] Lu Jianguo, Zhang Naikuan, Kui Li. Test and detection of low-voltage electrical appliances [M]. Tianjin: China Electric Power Press, 2007:65-66.
- [3] Ying Wu. Numerical Simulation and Characteristics Test of Temperature Field under Short-circuit Fault[C]//. *Proceedings of 2017 2nd International Conference on Modelling, Simulation and Applied Mathematics*,2017:93-96.
- [4] Wang Zezhong, Li Mingyang, Xuan Mengzhen, Huang Tianchao, Li Bing. Temperature Rise Test and Simulation of Single-Phase Four-Column Transformer under DC-Bias. *Transactions of China Electrotechnical Society*, 2021, 36(5): 1006-1013.
- [5] WANG Ning, MA Zhengrong, JIA Qingquan, DONG Haiyan. Voltage Notch Detection and Characteristic Parameter Identification Based on Phase Space Reconstruction. *Proceedings of the CSEE*, 2017, 37(18): 5220-5227.
- [6] Lijun Wang,Rui Wang,Xiaolin Li,Chao Yan. Temperature Rise Simulation of Medium Voltage Cubicle Type Gas Insulated Switchgear Based on Coupling of Multi-Physical Fields. [J]. *IEEE Access*,2019,7: 45395-45404.
- [7] Lu Jianguo, Zhang Naikuan, Kui Li. Test and detection of low-voltage electrical appliances [M]. Tianjin: China Electric Power Press, 2007:65-66.