

## Design of auxiliary viewing mirror for filter centering drum in GD121-AF12 filter assembler

Chengjian He<sup>1,\*</sup>, Xiaobo Lv<sup>2</sup>, Hao Zhang<sup>3</sup>, Xingjian Zhu<sup>1</sup>, Shuangjun Zhang<sup>1</sup>

<sup>1</sup> Hongyun Honghe Tobacco (Group) Co., Ltd., Kunming, China

<sup>2</sup> Hongta Tobacco (Group) Co., Ltd., Yuxi, China

<sup>3</sup> Hongyun Honghe Tobacco (Group) Co., Ltd., Qujing, China

\* Corresponding Author Email: 35578414@qq.com

**Abstract.** In order to solve the problem of observation blind area on the outer end face of the cigarette groove of the filter centering drum on the GD121—AF12 filter assembler, an auxiliary observation mirror was designed and installed on the inner wall nearby. According to the light reflection law, according to the space position the central position of the mirror, design the mirror surface support parts refer to the available screw holes on the mirror surface center and inner wall, and calculate the relative position and deflection angle of the support parts. Based on the above data, support parts are designed with Pro/E, and parts are made with 3D printer. After the improved equipment is blocked, the manual cleaning time is reduced to 3.2min/time, and the maintenance time is reduced by 67%, which effectively reduces the labor intensity of operators and improves the equipment efficiency.

**Keywords:** GD121-AF12 filter assembler; Law of light reflection; Filter centering drum; Auxiliary observation mirror; efficiency.

### 1. Introduction

GD121 cigarette machine unit is composed of GD121 cigarette machine and GD-AF12 filter assembler. It is a kind of double-flue high-speed coiling cigarette equipment produced by GD Company in Italy, and its nominal speed is 12,000 units /min [1]. In the normal production or debugging process of the equipment, when the drum wheel is blocked by cigarette, there is a blind area in the observation of the outer end face of the cigarette groove of the centering drum wheel, which leads to the tedious and time-consuming cleaning of the drum wheel by the operator. In recent years, for some studies on GD121 series cigarette machine units, Dejun Li et al. [2] designed a kind of pressing tobacco block, which effectively improved the qualified rate of cigarette quality. Jianjian Tao [3] developed a screw conveying device to reduce the failure rate of GD121A unit. In view of the cleaning of the cigarette machine unit, Hengle Pan et al. [4] improved the brush device of the ZJ116A unit to realize the automatic cleaning of the cigarette roller wheel. Dongzi Jiang et al. [5-7] optimized the cigarette cutting structure, designed the roller board and the cleaning device of SE cigarette channel, realized the automatic cleaning of the equipment, and improved the operating stability of ZJ112 unit. Ming Yang et al. [8] improved the suction device of tobacco dust in ZJ112 unit to reduce the clip rate of cigarette. Pengfei Tang et al. [9] developed a brush lubrication device, which improved the cleaning effect and life of the brush of ZJ118 unit. Feng Qian et al. [10] developed a single flue smoke strip automatic cleaning device on ZJ17 unit, which effectively improved the cleaning effect and production efficiency of the equipment. However, there is no report on the cleaning of the filter centering drum of GD121-AF12 filter assembler. Therefore, by analyzing the working principle of GD121-AF12 assembler on the drum wheel, an auxiliary viewing lens device is developed to reduce the maintenance intensity of operators.

## 2. Problems Exist

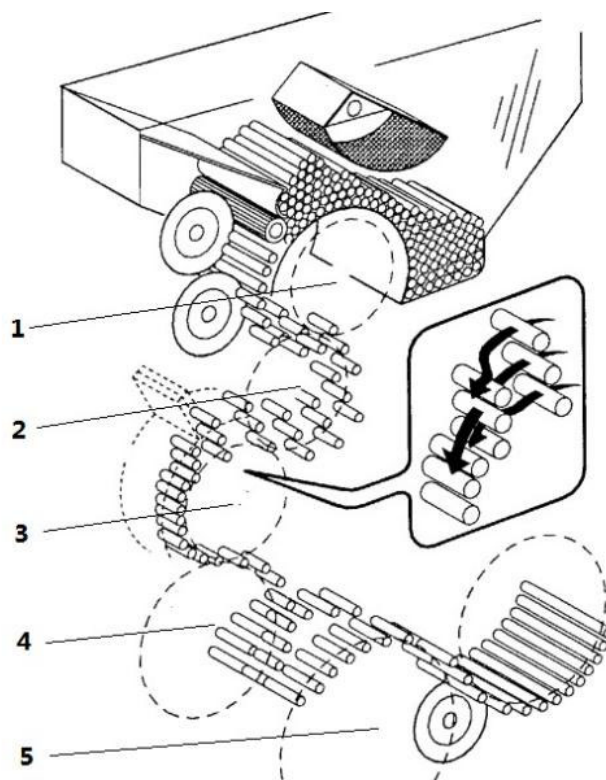

1. Filter cutting drum
2. Filter combination drum
3. Filter centering drum
4. Filter connecting drum
5. Cigarette separation drum

**Fig 1.** Status diagram of filter tip in each function drum.

The working process is shown in Figure 1: The filter received by the filter receiver is stored in the filter material library. With the counter-clockwise rotation of the filter cutting drum, the filter rod attached to the drum groove is cut into the double length filter after passing through the filter cutting knife and rotating with the filter cutting drum. The filter combination drum picks up the filter at the junction with the cutting drum. The inner row and outer row of the filter are not in the same straight line. The double length filter in the inner row and outer row will be put into the cigarette groove in the centering drum after the connection with the filter centering drum. The inner side of the inner row is flush with the inner end face of the cigarette groove, and the outer exclusive side is flush with the outer end face of the cigarette groove. After the filter receives the double filter on the centering drum, with the rotation of the drum wheel, the inside filter will slowly move outward, and the outside filter will slowly move inward. It is required that the center line of the double filter will coincide with the center line of the filter on the centering drum before the filter meets the centering drum. The double filter on the same line is connected to the filter connecting drum and receives the single cigarette from the cigarette separation drum. On the filter connecting drum, with the rotation of the drum wheel, the double cigarettes on both sides slowly converge to the center, and finally converge to double the length of cigarettes.

When the filter is transferred from the combination drum to the filter centering drum, the positioning of the inner and outer filters depends on the suction vacuum of the inner end face of the cigarette groove in the centering drum and the outer end face of the outer groove to absorb. When there is a filter residue attached to the inner end face of the filter carrier and the outer end face of the outer groove, the filter in the groove will be skewed and misplaced. When the filter is aligned on the drum wheel, the filter in the groove is still skewed and misaligned. When the filter is connected to the filter connecting drum, the crooked filter will fall out due to insufficient suction vacuum on the drum wheel, and the misplaced filter will interfere with the cigarette during the folding process, and both of them will fall down at the same time and cause blockage, as shown in Figure 2.

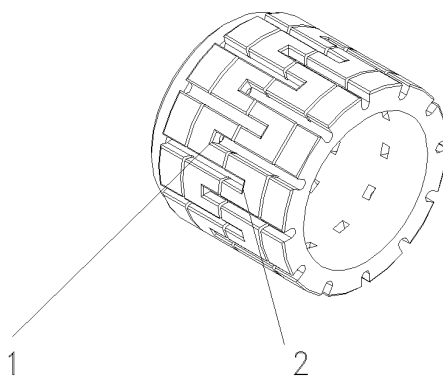

1. The outer end face of the filter centering drum 2.The outer end face of the filter centering drum

**Fig 2.** Picture of filter centering drum.

When troubleshooting, it is usually necessary to manually turn the machine for a week to check whether there is filter residue (fiber wool, filter wrapping paper, residual filter, etc.) in the filter centering drum groove one by one. If residue of the drum is found in the cigarette groove, the fault will no longer occur after cleaning the blockage. Because of the characteristics of the design of the filter groove, it is clear that there is filter residue in the inner end face and middle part. However, whether there is blockage on the outer end face is a blind spot from the operator's point of view. Therefore, it takes about 10min to completely eliminate the fault on average, which increases the maintenance time.

### 3. Improvement Method

#### 3.1. System structure design

In order to solve this problem, according to the law of light reflection, a mirror is placed at a certain position in the space, and the eye position of the operator during the operation of turning wheel is used as the fault observation point. After adjusting the Angle and position of the mirror, the blind area can be observed through the mirror. Therefore, the center of the blocking point can be seen in the mirror as the center point of the mirror.

After the position and Angle of the mirror are determined, according to the actual position of the mirror in the space, refer to the screw position on the inner wall of the machine as the location point of the support frame, according to the actual position space, logical planning is programmed to design the support frame between the inner wall of the machine and the mirror, soft mirror with a length of 40, a width of 20 and a thickness of 0.5mm can be selected.

#### 3.2. Calculation of position of mirror

##### 3.2.1. Deflection Angle of horizontal plane

A is selected as the blocking point, O is the mirror surface reflection point, B is the observation point (the point is the blocking point horizontally outward along the drum groove, the distance from the shield is 130), and  $O_1O$  is the normal line of the angular bisector of  $\angle POQ$ .  $O_1$  is the center of the filter centering drum, S is the intersection of the center point of the filter centering drum in the tangential direction, which is arranged along the filter combination drum, and the inner wall of the machine, T is the intersection of the center point of the filter centering drum in the horizontal radial direction and the inner wall of the machine, as shown in Figure 4. U is some point on the extension line of the tangential point of the outer edge of filter guide and the center point of the filter centering drum. M is the intersection point of the horizontal extended line of center of the filter centering drum and the outside diameter of the filter centering drum. For ideal observation, the mirror will always be perpendicular to the plane of the passing angular bisector  $O_1O$ . By measurement, Rfilte centering drum



$$DG = OF \sin \alpha = 20 \sin \alpha$$

$$BG = DB - DG = 505 - 20 \sin \alpha \quad OA = \sqrt{OG^2 + AG^2} = \sqrt{81.35^2 + (165 - 20 \sin \alpha)^2}$$

$$OB = \sqrt{OG^2 + BG^2} = \sqrt{81.35^2 + (510 - 20 \sin \alpha)^2}$$

By the law of cosines

$$\angle AOB = \arccos \frac{AO^2 + BO^2 - AB^2}{2 \cdot AO \cdot BO} \quad (3)$$

Computable degree of  $\angle AOB$ .

$$\angle AOG = \arctan \frac{AG}{OA} = \arctan \frac{165 - 20 \sin \alpha}{81.35}$$

According to the law of light reflection  $\angle AOH = \frac{1}{2} \angle AOB$ , and  $OH \perp FI$

$\angle AOH + \angle AOG + \alpha = 90^\circ$ , the method of gradual interpolation approximation is used.

Suppose that  $\alpha$  is  $0^\circ$ ,  $30^\circ$ ,  $60^\circ$  and  $90^\circ$  respectively, the corresponding values of  $\alpha + \angle AOG + \angle AOH$  can be calculated. It is proved that  $17.5^\circ < \alpha < 18.75^\circ$  at that time, the difference  $\alpha + \angle AOG + \angle AOH$  from  $90^\circ$  is small. During this period, when  $\alpha + \angle AOG + \angle AOH = 90^\circ$ , the median was inserted and the corresponding  $\alpha$  was calculated step by step (in the table I).

**Table I.**  $\alpha$  And corresponding table of related parameters.

$\alpha$	$\angle AOG$	$\angle AOH$	$\alpha + \angle AOG + \angle AOH$	$\sin \angle AOH$
17.5	62.93	8.92	89.36	0.95
18	62.91	8.93	89.84	0.95
18.25	62.90	8.94	90.09	0.95
18.5	62.89	8.94	90.33	0.95
18.75	62.87	8.95	90.57	0.95

The corresponding  $\alpha$  is  $18.25^\circ$ , and the corresponding  $\alpha + \angle AOG + \angle AOH$  is the closest to  $90^\circ$ . Corresponding  $\angle OFD = 161.75^\circ$ .

Through calculation, it can be seen that the designed mirror should be tilted  $18.25^\circ$  from the inner wall of the machine.

### 3.3. Design of mirror supporting parts

After measurement,  $OV=125$ ,  $VW=6$ ,  $WX=38$  on the  $O_1O$  line as shown in Figure 5. The positions of the two holes are the fastening positions of the mirror and the inner wall support, so a  $50 \times 10 \times 5$  cuboid base is designed on both sides of the holes, and is used for the connection of the base at the W and X positions. The cuboid base is tightly fitted to the inner wall. The mirror support body and the base form a staggered space, and part of the mirror support body is extended to combine it with the base into a part.

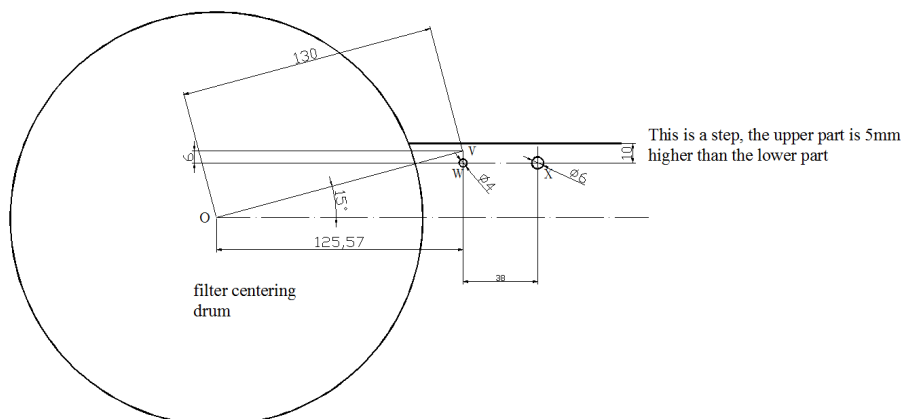

**Fig 5.** Relative position of screw hole and filter centering drum.

### 3.4. Production of supporting parts

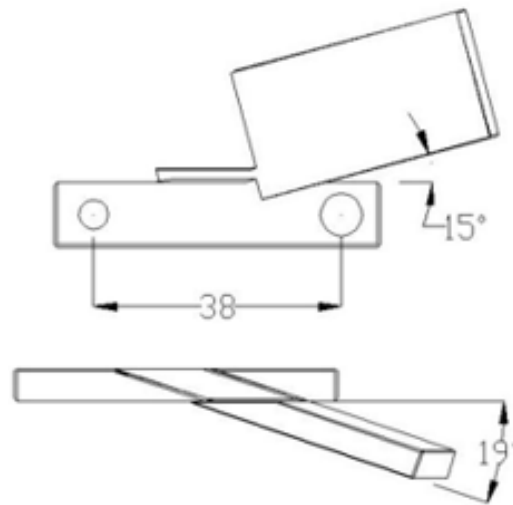

**Fig 6.** Schematic diagram of installation of mirror support.

ProE is used to complete the parts design, aluminum alloy is selected as the printing material, and 3D printing equipment can be used to quickly complete the parts production. The soft mirror with the size of the supporting surface of the cutting part is glued to the plane of the supporting part, and the supporting part is fixed on the inner wall of the machine through screws, as shown in Figure 6.

## 4. Effect Verification

### 4.1. Experimental design

Material: Yunyan "Zi" brand cigarette [provided by Kunming Cigarette Factory of Hongyun Honghe Tobacco (Group) Co., LTD.

Equipment: GD121 coiling unit (GD Company, Italy)

Methods: The running speed of GD121 coiler was set as 10000 PCS /min, and the manual cleaning time after the blockage of filter pair drum was counted for 10 times. To facilitate comparative analysis, the same operator is arranged for maintenance.

### 4.2. Data Analysis

As can be seen from Table II, after the alignment drum wheel of the improved GD121 coiler is blocked, the manual cleaning time is reduced from 9.8min/ time to 3.2min/ time, and the maintenance time is reduced by 67%, which effectively reduces the labor intensity of operators and improves the efficiency of the equipment.

**Table II.** Plugging time of filter centering drum before and after improvement.

time	before improvement (min)	after improvement(min)
1	13	3
2	12	4
3	8	2
4	8	2
5	9	4
6	10	4
7	7	4
8	8	2
9	11	3
10	12	4
average	9.8	3.2

## 5. Conclusion

A set of auxiliary viewing glasses is added to the improved GD121 coiling unit to help operators troubleshoot the blockage of the filter to the drum wheel, effectively reducing the cleaning time. Yunyan "Zi" brand cigarettes produced by GD121 coiling unit were tested. The results showed that: After the smoke loss caused by the blockage of the filter nozzle in the improved equipment, the manual cleaning time is reduced to 3.2min/ time, and the maintenance time is reduced by 67%, which improves the operation efficiency of the equipment, and reduces the frequency of the blockage of the drum again after cleaning.

## References

- [1] Kuitian ZHOU, "Comparison and Research on working principle of PROTOS2-2 and GD121PLUS/16K super high speed cigarette Feeder "// Proceedings of 2010 Academic Annual Meeting of China Tobacco Society, Chinese Tobacco Society, pp.345-350, 2010.
- [2] DeJun LI, Xiaotun CHEN, Hengle PAN," Modification of cigarette weight control system in GD121A cigarette maker". Tobacco Science & Technology, vol.A5, pp.95-99, 2021.
- [3] Jianjian TAO," Application of Screw Conveyor in GD121A Cigarette Machine". Internal Combustion Engine & Accessories, vol.A21, pp.237-238.2019.
- [4] Hengle PAN, Xiongwei FENG, Jun WANG," Development of automatic cleaning Device for rolling joint of ZJ116A Cigarette Machine ". Food & Machinery, vol.A6, pp.122-124, 132, 2020.
- [5] Dongzi JIANG, Dongliang SUN, Jianrong YANG, et al. "Improvement of Cutting Mechanism of final slitting drum wheel for YJ212 Plug Assembler". Tobacco Science and Technology, vol.A9, pp.24-25, 2011.
- [6] Dongzi JIANG, Jinchen WANG, Hongguo CHU, et al,"Research and design of washboard automatic cleaning device for YJ212 Plug Assembler". Automation and Instrumentation in Chemical Industry, vol.A4, pp.383-387, 412, 2017.
- [7] Dongzi JIANG, Jinchen WANG, Hongguo CHU, et al." Design of Automatic Cleaning Device for SE Cigarette Strip Conveying Channel of ZJ112 Cigarette Machine ". Tobacco Science and Technology, vol.A2, pp.82-86, 2018.
- [8] Ming YANG, Daoping GONG," Improvement of dust Suction Device for ZJ112 cigarettem maker garniture ". Journal of Hunan University of Arts and Science (Natural Science Edition), vol.A1, pp.43-45, 2018.
- [9] Pengfei TANG, Hengle PAN, Jun WANG," Development of Tool Roller Brush Lubrication Device for ZJ118 Cigarette Machine",Computer Knowledge and Technology,volA12,pp.242-244,2020.
- [10] Feng QIAN, Bo ZHOU, Meng SHU, et al,"Design and motion simulation of cigarette strip automatic cleaning device based on Adams ",Acta Tabacaria Sinica, vol.A3,pp.26-34,2022.