

Study on electromagnetic transient numerical simulation of single-phase inverter circuit

Yuxuan Gu, Fang Wang *, Ming Yang

School of electrical engineering, Shanghai Institute of electrical engineering, Shanghai, China

*Corresponding author e-mail: wangf@sdju.edu.cn

Abstract. With the continuous progress and development of new energy power generation technology, new energy grid and power electronic devices are widely used in power system, and the modeling requirements for electromagnetic transient simulation analysis of power system are higher and higher. Combined with the research status at home and abroad, this paper first analyzes the single-phase inverter circuit model, and establishes the mathematical model of single-phase inverter circuit in different switching states. Based on the stability, accuracy and efficiency of numerical integration algorithm, different numerical integration substitution methods are applied to the mathematical model established in each state of the circuit, and the electromagnetic transient analysis of single-phase inverter circuit is carried out the correctness and feasibility of the experimental results are verified by comparing with the results in Simulink.

Keywords: Electromagnetic transient simulation, numerical analysis, single phase inverter, power system.

1. Introduction

With the continuous development of new energy power generation technology, the grid connection technology of single-phase inverter circuit has been comprehensively developed. With the continuous expansion of power grid scale and the trend of large-scale application of power electronic devices in power system, the electromagnetic transient characteristics are becoming more and more complex.

Power system simulation refers to establishing a model according to the original power system, using the model for calculation and experiment, and studying the working behavior and characteristics of the power system within the specified time [1]. According to different models, power system simulation can be divided into physical simulation [2], digital simulation and digital physical hybrid simulation [3]. Because the simulation using physical modeling method will be subject to many restrictions, the advantages of high computing speed and large computing capacity of digital computer gradually replace physical simulation [4]. Digital simulation is to describe each component of power system by mathematical model, so as to reflect the change of physical quantity of power system in each state. During digital simulation, some models established are idealized, the actual problems can not be considered comprehensively, and it is difficult to accurately reflect the changes of voltage and current at millisecond level. Therefore, digital physical hybrid simulation is proposed, which is combined through the commonality of digital simulation and physical simulation, Because the simulation time scale can reach the microsecond level, it can accurately reflect the dynamic changes of voltage and current at the millisecond level, and improve the feasibility of power system simulation.

Electromagnetic transient process simulation mainly analyzes the fast transient process of the system in the process of fault or after disturbance [5]. In order to accurately obtain the dynamic characteristics of the power system and analyze different transient processes in the power system, people pay attention to the electromagnetic transient simulation of the power system. The electromagnetic transient program EMTP based on Dommel algorithm Electromagnetic transients program (EMTP) is usually used in electromagnetic transient simulation of power system [6] However, with the continuous expansion of power system scale and the continuous improvement of complexity, EMTP simulation program is more and more difficult to meet the research requirements. Therefore, scholars began to pay attention to the research of new electromagnetic transient simulation

program. However, numerical integration algorithm is the core of power system electromagnetic transient simulation analysis. The use of appropriate numerical integration method can improve the stability and accuracy of electromagnetic transient simulation Accuracy and efficiency. In order to select a better numerical integration algorithm to be applied to the simulation analysis at the level of digital physical model, four commonly used and effective numerical integration algorithms are selected for electromagnetic transient simulation analysis. The RL obtained from electromagnetic transient simulation under normal working state and open circuit fault state of single-phase inverter circuit is obtained by writing code using m file in MATLAB The time-domain curve of the current on the branch is compared with the Simulink simulation results. When the implicit trapezoidal integration method and the backward Euler method are used, the time-domain curve of the current on the RL branch is basically the same as the Simulink simulation results under the normal state and open circuit fault state of the single-phase inverter circuit.

2. Theoretical basis of simulation

2.1 Theoretical basis

The solution of various mathematical models and corresponding numerical integration algorithms in the power system constitute the electromagnetic transient simulation process of the power system [7]. For example, in the inductance branch shown in Figure 1, the differential equation of the branch is shown in formula (1):

$$v_k - v_m = L \frac{di_{km}}{dt} \tag{1}$$

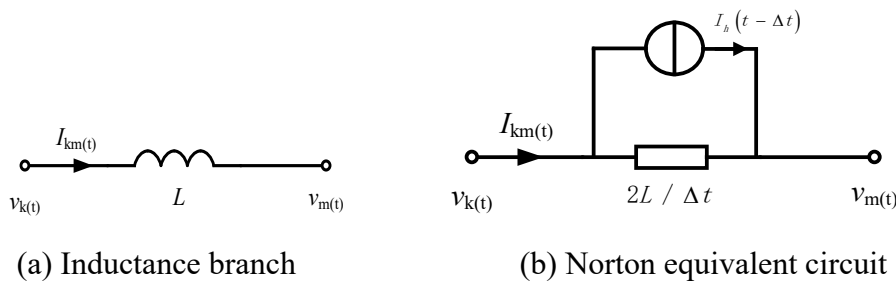

Figure 1. Inductance branch and Norton equivalent

The difference equation can be obtained by differential differentiation of formula (1). For example, the difference equation obtained by trapezoidal integration method for equation (1) is shown in equation (2):

$$i_{km}(t) = \frac{\Delta t}{2L} (v_k(t) - v_m(t)) + I_h(t - \Delta t) \tag{2}$$

Where: $I_h(t - \Delta t) = i_{km}(t - \Delta t) + \frac{\Delta t}{2L} (v_k(t - \Delta t) - v_m(t - \Delta t))$ Current source for history item

The difference equation shown in equation (2) can be expressed as the Norton equivalent circuit (adjoint circuit) shown in Figure 1 (b). The voltage term acting on the current time step is equivalent to conductance, and the electrical quantity of the previous step acting on the current time step is equivalent to the current source history term.

2.2 Problems and measures

With the continuous expansion of the scale of the power grid, a large number of power electronic devices are used in the power system, resulting in the increasing complexity of the power system[8]. The traditional digital off-line simulation has been difficult to meet the demand. In order to accurately reflect the change process of voltage and current in each power system from microsecond to millisecond, power system electromagnetic transient simulation has come into the attention of researchers. At the same time, in order to more accurately reflect the change process of power system

electromagnetic transient, the combination of digital physical hybrid simulation and electromagnetic transient has gradually become the research direction of scholars at home and abroad.

Because the numerical integration method is the basis of electromagnetic transient simulation, using different numerical integration methods plays an important role in electromagnetic transient simulation. Therefore, when selecting the numerical integration method, the three levels of calculation stability, calculation accuracy and calculation efficiency should be considered. Among them, the most important one in the calculation stability is a stability. The numerical integration algorithm with a stability can calculate any step length in terms of numerical stability. Therefore, the accuracy of the numerical integration algorithm with a stability is obviously better in small step simulation. Therefore, considering the calculation stability is the premise of electromagnetic transient simulation.

The calculation accuracy of numerical integration algorithm is determined by local truncation error. The smaller the local truncation error is, the higher the calculation accuracy is. Therefore, the calculation accuracy of different numerical integration algorithms is also different. The computational efficiency of numerical integration algorithm is of great significance to the real-time performance of electromagnetic transient simulation. In conclusion, the selection of appropriate numerical integration method has a vital impact on the real-time, stability and accuracy of electromagnetic transient simulation.

In order to select an appropriate numerical integration algorithm for digital physical hybrid simulation, four common numerical integration algorithms in electromagnetic transient simulation are selected. Through the digital electromagnetic transient simulation analysis of the current waveform on the RL branch under the normal working state and fault state of the single-phase inverter circuit, the appropriate numerical integration algorithm is selected after comparing with the waveform of Simulink simulation results. The next chapter will focus on the mathematical model of single-phase inverter circuit.

3. Mathematical model of single-phase inverter circuit

3.1 Mathematical model of single-phase inverter circuit under normal working state

Figure. 2 is a circuit diagram of a single-phase inverter circuit. The circuit realizes the DC-AC inverter process by turning on and off four switches in turn.

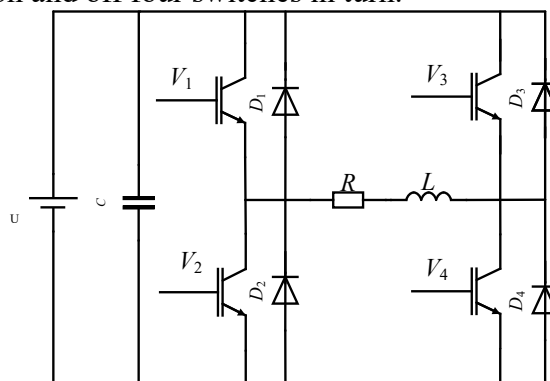

Figure 2. Single phase inverter circuit

At different times, the opening sequence of switch tube is shown in Figure 3:

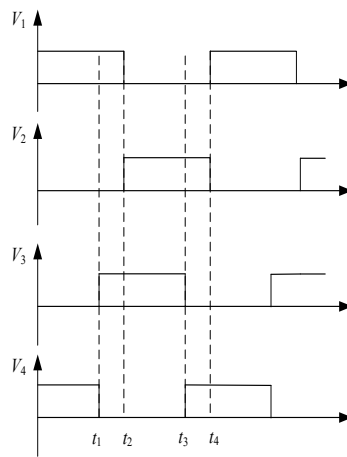

Figure 3. Different switching tube on sequence

When different switches are on at different times, the voltage and current directions on RL branch are different. Taking the process from on to off as an example, the switch is on at different times, and the simplified circuit model is shown in Figure 4. The simplified circuit of the switch from on to off is basically similar to the switch from on to off, but the direction of voltage and current is opposite to the process from on to off.

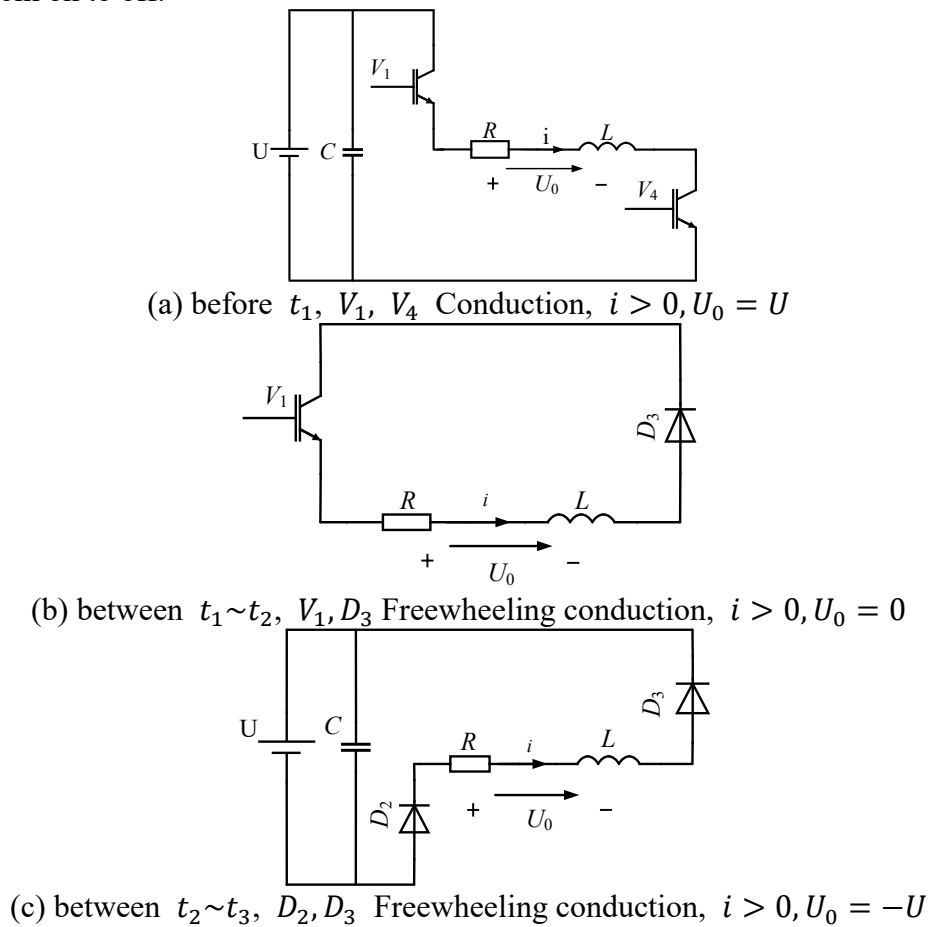

Figure 4. Switch on circuit diagram

The differential equations of each simplified circuit model in Figure 3 can be synthesized as shown in equation (3):

$$\begin{cases} (a) & L \frac{di}{dt} + Ri = U_0 \\ (b) & L \frac{di}{dt} + Ri = 0 \\ (c) & L \frac{di}{dt} + Ri = U_0 \end{cases} \quad (3)$$

It can be seen from equation (3) that when the switch is on, the switch freewheeling is on, the switch is on and the switch freewheeling is on, the differential equation form of the circuit is the same, but the current and voltage directions are different. Similarly, when the switch is freewheeling and freewheeling, the form of the circuit differential equation is the same, but the current direction is opposite. The above two working conditions are defined as working condition 1 and working condition 2 respectively.

3.2 Mathematical model of single-phase inverter circuit under open circuit fault

In real life, the switch used in single-phase inverter circuit has high working frequency, so the probability of fault is high. It is very easy to fuse the switch tube, resulting in the open circuit fault of the switch tube. Therefore, it can be seen that the open circuit fault is one of the most common faults in the single-phase inverter circuit.

In order to reflect the electromagnetic transient process of the current on the RL branch when the switch of single-phase inverter circuit breaks down, the process of the switch of single-phase inverter circuit breaking down is modeled and analyzed in this paper.

The circuit shown in Figure 5 is a single-phase inverter circuit. In case of open circuit fault of switch tube, the working conditions of open circuit fault of switch tube are basically the same, so this paper only analyzes the working conditions of open circuit fault of switch tube. Fig. 5 shows the four working states of the inverter circuit under the normal working state of the diode after the open circuit fault of the switch.

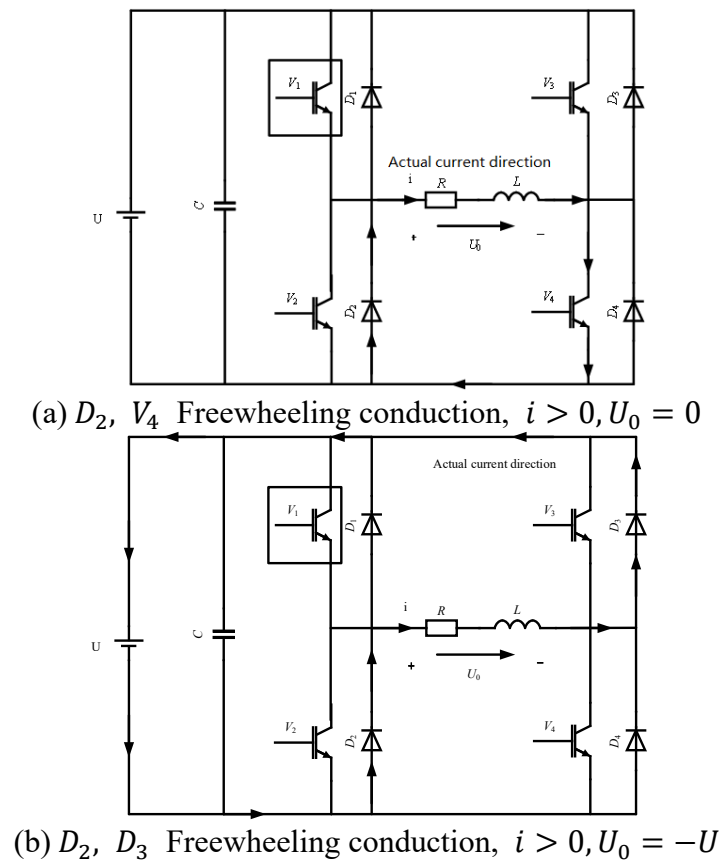

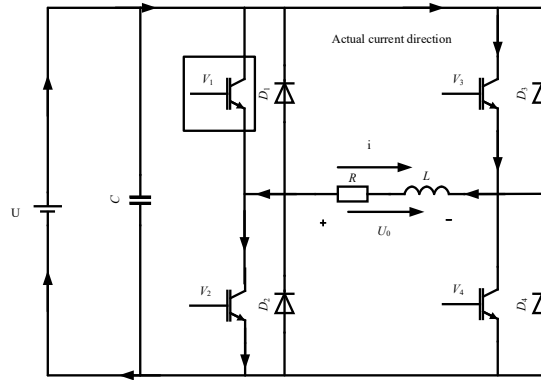

(c) V_2, V_3 conduction, $i < 0, U_0 = -U$

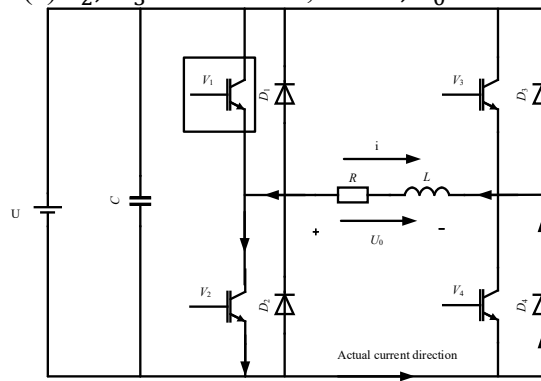

(d) V_2, D_4 Freewheeling conduction, $i < 0, U_0 = 0$

Figure 5. Circuit diagram of switch tube open circuit fault

In order to fully reflect the electromagnetic transient change process of the current on RL branch when the single-phase inverter circuit opens the switch, the time of the open circuit fault is selected at the normal conduction time of the switch. When (a) in Fig. 5 shows that the energy stored in the inductor will be released in case of open circuit fault of the switch, and (b) in Fig. 5, if the energy stored in the inductor is not exhausted after the switch is turned off at the specified turning off time, continue to release until the energy stored on the inductor is exhausted. The open circuit fault of the switch tube does not affect the normal operation of the switch tube.

The differential equation of each circuit model in Figure 5 can be synthesized as shown in equation (4):

$$\begin{cases} (a) & L \frac{di}{dt} + Ri = 0 \\ (b) & L \frac{di}{dt} + Ri = U_0 \\ (c) & L \frac{di}{dt} + Ri = U_0 \\ (d) & L \frac{di}{dt} + Ri = 0 \end{cases} \quad (4)$$

It can be seen from equation (4) that the differential equation form of the circuit is the same when the switch freewheeling is on and the switch freewheeling is on, but the current direction is opposite. Similarly, when the switch is free wheeling and on, the differential equation of the circuit has the same form, but the direction of voltage and current is opposite. The above two working conditions are defined as working condition 3 and working condition 4 respectively.

4. Integration method for electromagnetic transient simulation of single-phase inverter circuit

The modeling of single-phase inverter circuit uses a series of differential equations or algebraic equations to express the dynamic characteristics of the actual operation of the inverter circuit. Because the switching frequency of inverter circuit is high and the switching period is far less than 0.02s, the time-domain transient simulation of electromagnetic transient is generally studied on the millisecond time scale.

Because the electromagnetic transient is expressed in the form of differential equation, in order to simulate and analyze the electromagnetic transient, the circuit mathematical model of single-phase inverter circuit under different switching states is expressed in the form of differential equation. Because the most important part of electromagnetic transient simulation of single-phase inverter circuit is the solution process of differential equations, using different numerical integration methods to solve differential equations has different degrees of impact on the accuracy and efficiency of the model. Selecting an appropriate numerical integration method has a vital impact on electromagnetic transient simulation. At present, the most commonly used integration methods in electromagnetic transient simulation are implicit trapezoidal integration method, backward Euler method, second-order gear method and Simpson method[9~12]. In order to select a suitable and effective numerical integration algorithm from the above four numerical integration algorithms for digital physical hybrid simulation, the above four numerical integration algorithms are briefly analyzed and applied to electromagnetic transient simulation in single-phase inverter circuit.

4.1 Implicit trapezoidal integral method

Implicit trapezoidal integration method is widely used in electromagnetic transient simulation analysis because of its simple, flexible and efficient operation. Its basic principle is that the integrated quantity is equivalent to the sum of several small trapezoidal areas. When the selected step size is smaller, the accuracy of integration is higher. Therefore, the implicit trapezoidal integration method has large error at low frequency and small error at high frequency, and has second-order accuracy and a stability. The integration formula of implicit trapezoidal integration method is:

$$y_{n+1} = y_n + \frac{\Delta t}{2} [f(t_n, y_n) + f(t_{n+1}, y_{n+1})] \quad (5)$$

4.1.1 The single-phase inverter circuit works normally

When the implicit trapezoidal integration method is adopted in condition 1, the analytical equation of the circuit can be obtained as shown in equation (6), but the voltage direction is different under different conditions, which may be positive or negative.

$$i(t) = \frac{2L - \Delta t R}{2L + \Delta t R} i(t - \Delta t) + \frac{2\Delta t}{2L + \Delta t R} U_0 \quad (6)$$

When the implicit trapezoidal integration method is adopted in condition 2, the analytical equation of the circuit can be obtained as shown in equation (7):

$$i(t) = \frac{2L - \Delta t R}{2L + \Delta t R} i(t - \Delta t) \quad (7)$$

4.1.2 Open circuit fault of single-phase inverter circuit

When the implicit trapezoidal integration method is adopted in condition 3, the analytical equation of the circuit can be obtained as shown in equation (8):

$$i(t) = \frac{2L - \Delta t R}{2L + \Delta t R} i(t - \Delta t) + \frac{2\Delta t}{2L + \Delta t R} U_0 \quad (8)$$

When the implicit trapezoidal integration method is adopted in condition 4, the analytical equation of the circuit can be obtained as shown in equation (9):

$$i(t) = \frac{2L - \Delta t R}{2L + \Delta t R} i(t - \Delta t) \quad (9)$$

4.2 Backward Euler method

The backward Euler method adopts fixed step size, simple calculation, high calculation efficiency, first-order accuracy and a stability, and can carry out system simulation of rigid stability. The integral formula of the backward Euler method is:

$$y_{n+1} = y_n + \frac{\Delta t}{2} [f(t_n, y_n) + f(t_{n+1}, y_{n+1})] \quad (10)$$

4.2.1 The single-phase inverter circuit works normally.

When the backward Euler method is adopted for condition 1, the analytical equation of the circuit can be obtained, as shown in equation (11):

$$i(t) = \frac{L}{L+\Delta tR} i(t - \Delta t) + \frac{\Delta t}{L+\Delta tR} U_0 \quad (11)$$

When the backward Euler method is adopted for condition 2, the analytical equation of the circuit can be obtained, as shown in equation (12):

$$i(t) = \frac{L}{L+\Delta tR} i(t - \Delta t) \quad (12)$$

4.2.2 Open circuit fault of single-phase inverter circuit.

When the backward Euler method is adopted for condition 3, the analytical equation of the circuit can be obtained, as shown in equation (13):

$$i(t) = \frac{L}{L+\Delta tR} i(t - \Delta t) + \frac{\Delta t}{L+\Delta tR} U_0 \quad (13)$$

When the backward Euler method is adopted for condition 4, the analytical equation of the circuit can be obtained, as shown in equation (14):

$$i(t) = \frac{L}{L+\Delta tR} i(t - \Delta t) \quad (14)$$

4.3 Second order gear method

The second-order gear method has general accuracy and good stability, but because it uses the values of the first two times to calculate the current time, its calculation efficiency is lower than that of trapezoidal integration method and backward Euler method. Its integration formula is:

$$y_{n+1} = \frac{4}{3} y_n - \frac{1}{3} y_{n-1} + \frac{2}{3} \Delta t [f(t_{n+1}, y_{n+1})] \quad (15)$$

4.3.1 The single-phase inverter circuit works normally.

When the second-order gear method is adopted for condition 1, the analytical equation of the circuit can be obtained, as shown in equation (16):

$$i(t) = \frac{4L}{3L+2\Delta tR} i(t - \Delta t) - \frac{L}{3L+2\Delta tR} i(t - 2\Delta t) + \frac{2\Delta t}{3L+2\Delta tR} U_0 \quad (16)$$

When the second-order gear method is adopted for condition 2, the analytical equation of the circuit can be obtained, as shown in equation (17):

$$i(t) = \frac{4L}{3L+2\Delta tR} i(t - \Delta t) - \frac{L}{3L+2\Delta tR} i(t - 2\Delta t) \quad (17)$$

4.3.2 Open circuit fault of single-phase inverter circuit.

When the second-order gear method is adopted for condition 3, the analytical equation of the circuit can be obtained, as shown in equation (18):

$$i(t) = \frac{4L}{3L+2\Delta tR} i(t - \Delta t) - \frac{L}{3L+2\Delta tR} i(t - 2\Delta t) + \frac{2\Delta t}{3L+2\Delta tR} U_0 \quad (18)$$

When the second-order gear method is adopted for condition 4, the analytical equation of the circuit can be obtained, as shown in equation (19):

$$i(t) = \frac{4L}{3L+2\Delta tR} i(t - \Delta t) - \frac{L}{3L+2\Delta tR} i(t - 2\Delta t) \quad (19)$$

4.4 Simpson method

Simpson method is a way to solve the definite integral value by using parabolic integral function. It divides the integral into several segments, uses Simpson formula for each segment on the integrand function, and adds it up step by step to obtain the numerical solution of the original integral. Therefore, Simpson method has high calculation accuracy and stability, but because its order is two, its calculation efficiency is lower than that of implicit trapezoidal integration method and backward Euler method. The integral formula is:

$$y_{n+1} = y_n + \Delta t \left[\frac{1}{3} f(t_{n+1}, y_{n+1}) + \frac{4}{3} f(t_n, y_n) + \frac{1}{3} f(t_{n-1}, y_{n-1}) \right] \quad (20)$$

4.4.1 The single-phase inverter circuit works normally.

When Simpson method is adopted for condition 1, the analytical equation of the circuit can be obtained, as shown in equation (21):

$$i(t) = \frac{3L-4\Delta tR}{3L+\Delta tR} i(t - \Delta t) - \frac{\Delta tR}{3L+\Delta tR} i(t - 2\Delta t) + \frac{6\Delta t}{3L+\Delta tR} U_0 \quad (21)$$

When Simpson method is adopted for condition 2, the analytical equation of the circuit can be obtained, as shown in equation (22):

$$i(t) = \frac{3L-4\Delta tR}{3L+\Delta tR} i(t - \Delta t) - \frac{\Delta tR}{3L+\Delta tR} i(t - 2\Delta t) \quad (22)$$

4.4.2 Open circuit fault of single-phase inverter circuit.

When Simpson method is adopted for working condition 1, the analytical equation of the circuit can be obtained, as shown in equation (23):

$$i(t) = \frac{3L-4\Delta tR}{3L+\Delta tR} i(t - \Delta t) - \frac{\Delta tR}{3L+\Delta tR} i(t - 2\Delta t) + \frac{6\Delta t}{3L+\Delta tR} U_0 \quad (23)$$

When Simpson method is adopted for condition 2, the analytical equation of the circuit can be obtained, as shown in equation (24):

$$i(t) = \frac{3L-4\Delta tR}{3L+\Delta tR} i(t - \Delta t) - \frac{\Delta tR}{3L+\Delta tR} i(t - 2\Delta t) \quad (24)$$

5. Experimental comparison

In order to select the numerical integration algorithm with good accuracy and high stability for digital physical hybrid simulation, the above four widely used numerical integration methods are applied to the mathematical models of single-phase inverter circuit under different working states, and the current waveforms on RL branch are compared. Firstly, the software level simulation is realized by writing code through M file in MATLAB, and finally compared with the simulation results of Simulink. Fig. 6 is the comparison diagram of RL branch current obtained by selecting different numerical integration analytical circuit models for single-phase inverter circuit under normal working state, and Fig. 7 is the comparison diagram of RL branch current obtained by selecting different numerical integration analytical circuit models for single-phase inverter circuit under fault state.

The parameters of each element of the single-phase inverter circuit are: voltage 10V, resistance 2, inductance 1.8h, the switch is an ideal switching device, and the simulation step is.

As shown in Figure 3 in Section 2.1 of the article, the single-phase inverter circuit turns off and on when it is, turns off and on when it is, turns on and off when it is, and turns on and off when it is.

When the single-phase inverter circuit breaks down, in order to fully reflect the electromagnetic transient change process of the current on the RL branch when the single-phase inverter circuit breaks down, the opening time of the switch is selected at. The opening and closing time of other switches is the same as the normal working state of single-phase inverter circuit.

As shown in Figure 6, when the single-phase inverter circuit is in normal working state, before the time, the current waveform on RL branch obtained by Simpson method rises too fast, and there is a huge gap in Simulink simulation results, which does not reach the expected results. The current waveforms on RL branch obtained by implicit trapezoidal integration method are basically

overlapped by Simulink simulation results. Therefore, it can be seen that the effect of implicit trapezoidal integration method is the best. The current waveform on RL branch obtained by backward Euler method has a little error with Simulink simulation waveform before time, but the overall error is small, and the effect of backward Euler method is better. In addition, the current waveform on the RL branch obtained by the second-order gear method generates a current of up to 7 amps when the switch is turned off, which exceeds the rated current, and will produce a current spike when the switch is acting, with the largest overall error and poor accuracy. Through the above analysis, it can be seen that the implicit trapezoidal integration method has high accuracy and the effect is the best.

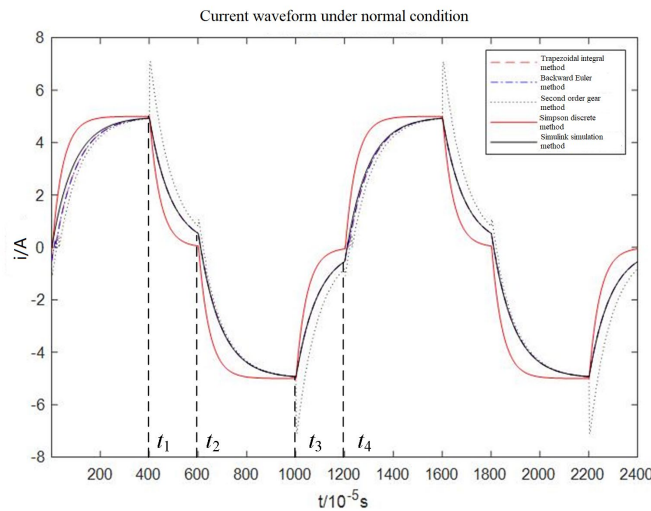

Figure 6. Current waveform under normal condition

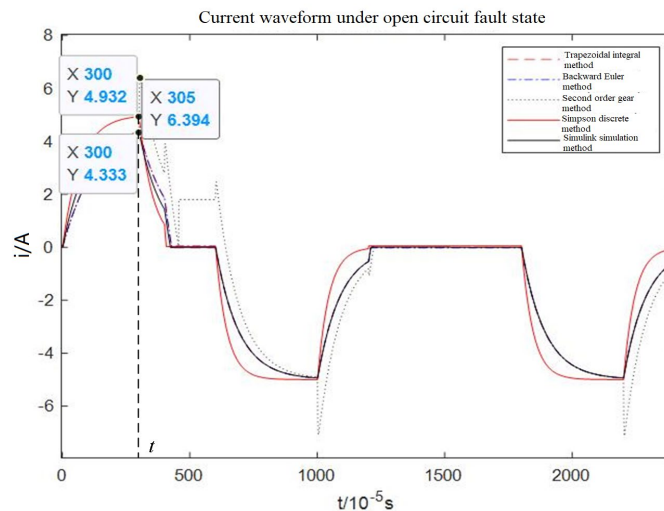

Figure 7. Current waveform under open circuit fault state

As shown in Fig. 7, when the single-phase inverter circuit has an open circuit fault, the current waveform on RL branch obtained by electromagnetic transient analysis using Simpson method reaches 4.932 amps at, which is inconsistent with the actual situation, and because the current waveform rises and falls too fast, it can not accurately reflect the actual change of current. The current waveform on RL branch obtained by electromagnetic transient analysis using implicit trapezoidal integral method and backward Euler method has a little error with Simulink simulation waveform before switch open circuit fault, but it is basically consistent with the allowable range of error, When comparing the above two methods, it is found that the current waveform on the RL branch obtained by the implicit trapezoidal integration method is closer to the Simulink simulation waveform and the

error is smaller. The current waveform on RL branch obtained by electromagnetic transient analysis using second-order gear method will produce a large number of current spikes.

From the above analysis, it can be seen that the implicit trapezoidal integral method and backward Euler method are still stable and have high accuracy. Although Simpson method has high stability, its accuracy is poor, while the second-order gear method has poor overall stability.

6. Conclusion

Based on the above analysis, this paper discusses the mathematical model of single-phase inverter circuit under normal working state and open circuit fault, The mathematical models of single-phase inverter circuit under normal working state and open circuit fault state are differentiated by the above four numerical integration methods. The calculation expressions are numerically simulated by writing codes in m file in MATLAB, and compared with the simulation results of Simulink. The experimental analysis shows that the implicit trapezoidal integration method can accurately reflect the electromagnetic transient simulation waveform of the current on the RL branch whether in the normal working state or open circuit fault state of the single-phase inverter circuit, and has strong universality and practicability. It provides a reference for the future research in digital physical hybrid simulation, and lays a foundation for selecting an appropriate numerical integration algorithm for power system electromagnetic transient simulation.

In order to more accurately reflect the electromagnetic transient changes of the current on the load branch of the single-phase inverter circuit under the normal working state of the circuit and the open circuit fault state, the electromagnetic transient changes of the current on the load branch of the single-phase inverter circuit need to be further studied when considering the addition of switching devices at the opening and closing time of the switch.

Acknowledgments

This work was financially supported by Scientific research project of Shanghai Municipal Commission of science and technology (17DZ1201200) fund.

References

- [1] Wang Lei, Chang Xiqiang, Aibibule Saitaer, Xing Zhanli, Chen Jiang, Li Hongzhong. Mathematical model and electromagnetic transient analysis of basic network elements [J]. *Electrical Measurement & Instrumentation*, 2020, 57 (16): 44-50.
- [2] Weinikov. *Physical simulation of power system* [M]. China Industry Press, 1962
- [3] Gao Yuan, Chen Yun Ping, Liu Hui Jin. Power system physical and digital joint real time simulation [J]. *Power grid technology*, 2005, 29 (012): 77-80.
- [4] Dong Yifeng, Wang Yanliang, Han Ji, et al. Overview of efficient electromagnetic transient simulation technology in power system [J]. *Chinese Journal of electrical engineering*, 2018 (8): 2213-2231.
- [5] Su Guoliang, Wang Yuhong, Dai Hanguang, et al. Hybrid simulation of Debao DC electromagnetic electromechanical transient based on ADPSS [J]. *Electrical measurement and instrumentation*, 2016 (1): 26-31
- [6] Watson, N., arilaga, et al. *Electromagnetic transient simulation of power system* [M]. China Electric Power Press, 1900
- [7] Wang Chengshan, Li Peng, Wang Liwei. Research progress of electromagnetic transient simulation algorithms for power systems [J]. *Automation of Electric Power Systems*, 2009, 33(07): 97-103.
- [8] Dong Yifeng, Wang Yanliang, Han Ji, et al. Overview of high-efficiency electromagnetic transient simulation technology for power systems [J]. *Proceedings of the Chinese Society of Electrical Engineering*, 2018(8): 2213-2231.

- [9] Zou Yuzhi, Ge Dandan. Research on Application of implicit trapezoidal integration method in power system digital simulation [J]. *Electrical technology*, 2017, 000 (010): 51-54.
- [10] Jiang Delong, Yin Shuping, Wang Kewen, et al. Application of implicit improved Euler method in transient stability analysis [J]. *Automation instrumentation*, 2011 (10): 13-16.
- [11] Liu Yunhua. Notes on second order gear method for rigid equations [J]. *Journal of Beijing University of Aeronautics and Astronautics*, 1990 (03): 83-92.
- [12] Shang Ying. Comparison of electromagnetic transient algorithm and Research on nonlinear model [D]. Shandong University, 2009
- [13] Li Mengdi. Modeling and electromagnetic transient simulation of three phase PWM converter [D]. Hefei University of technology, 2020
- [14] Jiang Wei, Wang Cong, Wang Shuo, et al. Internal fault analysis and location of full bridge inverter [C] / annual conference of China power supply society. CNKI; Wang Fang, 2012:7-11
- [15] Liu Shui, Wang haiqun, Wang Zhijie, et al. Full digital real time simulation technology of power system [J]. *Science and technology and innovation*, 2017, 000 (018): 20-22.
- [16] Zhou Cheng, he Renmu, Wang Jili, et al. Simulation accuracy evaluation of power system component model [J]. *Power grid technology*, 2009, 33 (014): 12-15.
- [17] Jin Qimei, Yang Weiguo. Summary of power system physical simulation [J]. *Journal of electrical technology*, 1999
- [18] Tian Fang, Huang Yanhao, Shi Dongyu, et al. Development trend of power system simulation analysis technology [J]. *Chinese Journal of electrical engineering*, 2014
- [19] Wang Yafang. Matlab simulation and electronic information application [M]. People's Posts and Telecommunications Press, 201104.210
- [20] Yuan Xinding. Numerical Solution of Initial Value Problems of Stiff Ordinary Differential Equations [M]. Science Press, 1987.
- [21] Dai Hanyang, Tang Yong, Song Xinli, Su Zhida, Gu Zhuoyuan, Xiang Yinxing, Su Yi. Overview of numerical integration algorithm for power system dynamic simulation [J]. *Power grid technology*, 2018, 42 (12): 3977-3984.