

Application Research of BIM Technology in Bridge Monitoring

Xinran Li^{1*}, Bohua Liu¹, Can Deng¹, Qi Guo²

¹Chongqing College of Architecture and Technology, Chongqing, China

²Chongqing Institute of Geology and Mineral Resources, Chongqing, China

* Corresponding Author Email: lixinran@cqjzyx.cn

Abstract. According to the development situation of BIM technology and the application of bridge monitoring methods, this article proposes the design and application of bridge monitoring platform based on BIM technology, integrating the collection, data analysis, data transmission, safety assessment and prediction of basic bridge data. Then, according to the bridge load, the overall structure and the local data, it conducts the overall prediction and evaluation of bridge safety status, which can provide the method reference for the later maintenance and operation of the bridge.

Keywords: Bridge monitoring platform, BIM technology, Safety assessment, Maintenance, Data.

1. Introduction

Building Information Modeling builds a virtual building in a computer through digital technology. A building information model can provide complete, consistent and logical building information database. BIM technology can not only realize the dynamic link between planning and engineering specialty, but also the main means to manage a project data information [1]. With the improvement of construction technology and information transfer technology, BIM has become another new topic explored in the construction industry. It has been applied in many fields such as house construction, road and drainage, water, urban rail, road and bridge, and runs through design, construction, management and other aspects. This paper mainly explores the application of BIM technology in bridge monitoring.

BIM technology has been widely used in the civil transportation industry at home and abroad, mainly to realize the automation ability of engineering in the stages of design, construction, operation, but the application of BIM technology in bridge monitoring is rarely involved. The cost of bridges is relatively high, the structure is complex, and there are strict requirements for post-maintenance conditions, which require high-level design drawings, construction conditions and post-maintenance technology support [2-4]. This paper mainly studies the application of BIM technology in the field of bridges from the post-maintenance of bridges, establishes a bridge monitoring and maintenance platform based on BIM technology, and realizes the data management of various bridge information.

The bridge monitoring system is to monitor and control the bridge structure in real time, and analyze the complete state of the bridge through the data and structural changes at the same position of the bridge at different times. Bridge monitoring is a comprehensive technology, which mainly includes knowledge of bridge structure frame, stress level, sensing technology, data transmission, data analysis and processing, computer technology and other aspects [3-6]. Bridge monitoring is to reflect various changes of the bridge into a series of data, and transmit these data to the data control center through wired or wireless communication. A monitoring method for real-time analysis of changes [7].

The bridge monitoring method is mainly used to install sensors on the steel box girder bridge to monitor the vibration, tilt degree and change parameters of the bridge, and realize the real-time analysis of the bridge life cycle and the systematic management and sharing of various data. With the development of sensors and other technical equipment, optical fiber strain sensor, temperature sensor and inclinometer are also applied in the bridge monitoring system, monitoring efficiency has been greatly improved, but also can reflect all kinds of subtle changes of the bridge. Bridge monitoring can find the disease and repair the disease in time, which can effectively prolong the service life of the bridge. This paper establishes a bridge monitoring platform based on BIM technology, which can

provide a new idea and thought for bridge monitoring according to various data, parameters and monitoring contents.

2. Construction of bridge monitoring system based on BIM technology **Selecting a Template**

The bridge monitoring system based on BIM technology is a monitoring platform integrating data collection, data analysis, data transmission, safety assessment and prediction [8-9]. According to the structural characteristics of the bridge and the needs of bridge health, bridge prediction and safety assessment, the bridge monitoring system is established from five aspects: sensor, data collection and communication, data processing and management, comprehensive assessment and bridge management.

2.1. The sensor

According to different types of sensors, bridge structural deformation, strain, cracks, cable forces and simulation environment can be monitored. Its technical points are:

(1) Give full play to the advantages of visualization and 3D modeling of BIM technology. The BIM technology is used to simulate the natural environment of the bridge, and the relevant performance of Revit software is used to quickly model, observe whether there are cracks in the bridge deck, whether the bridge pier is sunken, whether the abutment is offset, so as to determine the type, placement position and monitoring content of the sensor.

(2) The bridge monitoring point must be representative, accurate and practical, and can reflect the overall structure of the bridge comprehensively and accurately, and meet the requirements of safety assessment and prediction.

(3) The sensor must have the characteristics of anti-interference and persistence, and protective measures must be taken to the sensor to ensure that it is not affected by temperature, electromagnetic interference and other interference.

(4) The sensor must have the characteristics of anti-interference and persistence, and at the same time, it must take protective measures to ensure that it is not affected by temperature, electromagnetic interference and so on.

2.2. Data collection and communication

Data collection and communication mainly include signal processing, data collection and data communication. Signal processing is to enlarge, filter and convert the photos and sensor information to analog and digital. Data collection is to sample, store and preprocess data. Data communication is to control the reception of signals and complete the transmission of data. Its technical points are:

(1) It can provide photos and complete data information meeting the accuracy requirements for the bridge monitoring system, so that the system tends to evaluate the safety state.

(2) Different collection schemes are adopted according to different characteristics of data. The data is preprocessed and collected synchronously.

(3) The equipment used for data collection and communication must be able to adapt to environmental changes, with good compatibility and strong durability.

2.3. Data processing and management

Through the database management software to bridge data information (mainly divided into static data information and dynamic data information, static data information for bridge geographical location, bridge design information and load information; Dynamic data information for bridge engineering daily inspection information, regular inspection information and special inspection information) unified management, classification, archiving and storage; Its technical points are:

(1) Realize unified management, classification, archiving and storage of data.

(2) Backup data to prevent loss, and have certain security protection measures to prevent data theft and damage.

(3) To achieve a large number of data retrieval function, data with modification and maintenance function, to ensure that the information in the database can be timely modified, to provide guarantee for the later bridge maintenance data information timely update.

2.4. Comprehensive evaluation

Comprehensive evaluation is to verify the structure and damage state of the bridge according to the processed data, and predict and evaluate the safety status of the bridge based on the verification results, so as to achieve a comprehensive and targeted analysis of the bridge load, the overall structure, local data and the surrounding environment of the bridge. Its technical points are:

(1) It can analyze the monitoring data and make hierarchical prediction, classify and record different types of bridge failures, and make targeted and effective plans.

(2) According to various data analysis and bridge damage state verification results, statistical monitoring results, comparative analysis of various monitoring data, make the overall prediction and assessment of bridge safety status.

2.5. Bridge monitoring platform

The bridge monitoring platform integrates data collection, data analysis, data transmission, safety assessment and prediction, and presents the bridge structure status, surrounding environment and various design data in the form of data through the platform, and can update the data in the system in real time. The 3d visualization software in BIM is used to establish the human-computer interaction interface and provide the three-dimensional display and online analysis of monitoring data for the bridge monitoring platform. Its technical conditions are:

(1) Provide convenient input interface for bridge data update, can dynamically monitor various states of the bridge, and make safety prediction and prediction information prompt, etc. If the bridge structure cracks and other diseases, there will be an alarm function and alarm time and alarm content prompt; At the same time, the situation of alarm content processing and processing results are presented in the form of charts.

(2) Real simulation of bridge structure based on BIM 3d simulation technology; Combined with the BIM mass data management function, the data can be presented in the form of reports, graphs and other intuitive forms.

(3) To achieve a large number of data retrieval function, data with modification and maintenance function, to ensure that the information in the database can be timely modified, to provide guarantee for the later bridge maintenance data information timely update.

3. Demonstration of bridge monitoring platform

In order to ensure the safe operation of Bridges and make up for the shortage of regular inspection of bridge quality, the effective guarantee measure is to build the bridge operation status monitoring system on the bridge. The bridge operation status monitoring system can obtain the characteristic information of the bridge structure stably and reliably and grasp its operation status in real time by using the sensors permanently installed on the key positions of the bridge structure. At the same time, the system effectively combines the daily inspection and regular inspection to accurately evaluate the static and dynamic safety, durability and applicability of the bridge structure, understand the safe service status of the structure in real time and give timely warning to its dangerous state and potential threats, so as to escort the safe operation of the bridge.

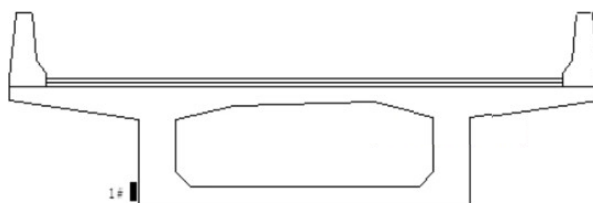
Through the database management software to bridge data information (mainly divided into static data information and dynamic data information, static data information for bridge geographical location, bridge design information and load information; Dynamic data information for bridge engineering daily inspection information, regular inspection information and special inspection information) unified management, classification, archiving and storage; The collected data are processed and analyzed using ProjectWise software. Interface software is used to complete data

transmission, forming a network system to control the work of monitoring stations and sensors and other equipment. Promote the data of bridge monitoring information and provide data basis for bridge safety monitoring. Its technical points are:

Classify the bridge according to the unit and line location of the bridge, directly click the bridge structure to be viewed on the map interface, and click to enter the three-dimensional structure diagram of the bridge (see Figure 1). In order to determine the position of the sensor more accurately, the arrangement of each monitoring point can also generate a three-dimensional structure diagram, as shown in Figure 2.

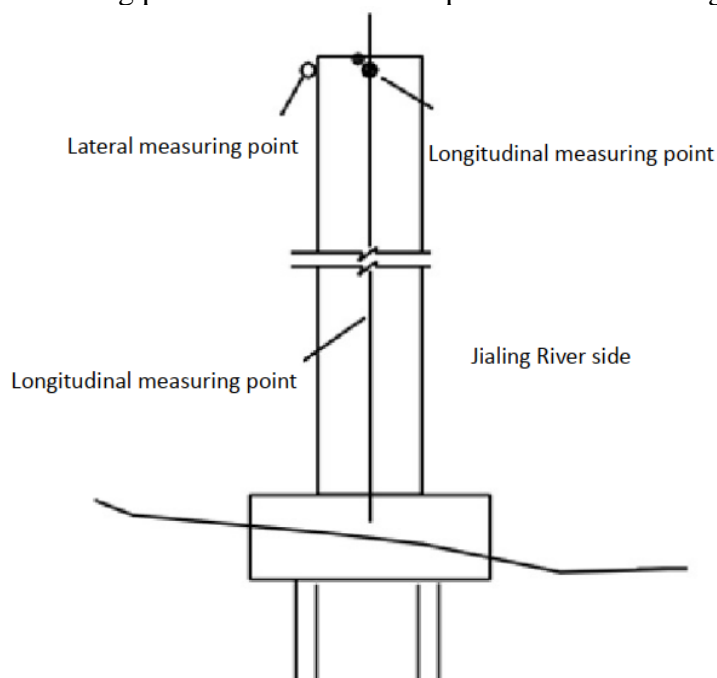


Figure 1. Schematic diagram of the three-dimensional structure of the bridge



(a)

(a) Layout of measuring points for horizontal displacement monitoring of beam body



(b) Layout of monitoring points for pier tilt monitoring

Figure 2. Example diagram of local monitoring point layout

Manage the basic data of the bridge in combination with the three-dimensional structural diagram of the bridge, including unified management of the monitoring content, pre-analysis of the monitoring report, and bridge operation status and other data information; According to various data of the bridge, basic information (front and side photos of the bridge) and 3D structural model, etc., use BIM data processing software to calculate the stress of the bridge; Update, and make classification management according to the changes of bridge dynamic information. Each type of dynamic data information is saved in a separate folder for easy query.

By clicking on the bridge monitoring point, you can query the basic information of the bridge, including the bridge pile number, bridge structure, pier and abutment, etc., and update the bridge maintenance information in time.

4. Conclusion

The bridge operation status monitoring system automatically monitors the environmental conditions and bridge response in real time and displays the results intuitively. Especially in emergencies, the bridge operation status information can be obtained in the first time. Identification of structural damage and emergency warning of structural abnormal reactions; Long-term tracking of structural state change trends provides a basis for bridge maintenance management decisions, and provides big data support for its life-cycle safety management; They complement each other with regular routine testing and structural testing, and jointly provide objective and scientific data for bridge management departments and experts, improve the level of bridge maintenance management, and greatly improve the safety of bridge operation.

In the bridge monitoring platform, the advantages of VISUALIZATION and 3D modeling of BIM technology are given play to establish the 3d structure diagram of the bridge. According to the real scene modeling technology in BIM technology, the natural environment around the bridge is displayed. At the same time, the powerful data processing ability of BIM is utilized to process and analyze the collected data information by using Project Wise software. The bridge monitoring platform based on BIM technology realizes the data processing and information management of bridge maintenance, which provides a new idea for the safety prediction and maintenance of Bridges.

Acknowledgments

This paper is from the project Study on the Latest Activity Age of Rongchang-Luxian Section of Huayingshan Fault Belt in Chengdu-Chongqing economic circle.

Item No. CSTB2022NSCQ-MSX1618.

References

- [1] Housner G W, Bergman L A, Caughey T K, et al. S tructural control: Past, present, and future [J]. Journal of Engineering M echanics, 1997, 123 (9): 897 - 971.
- [2] M yroll F, Dibiagio E. Instrumentation for monitoring the S karnsunder Cable-stayed Bridge [A]. Krokeborg J Proceedings of the 3rd S ym posium on S trait Crossing [C]. Rotterdam: Balkema, 1994. 207 - 215.
- [3] Andersen E Y. Structural monitoring of the Great Belt East Bridge [A]. Krokeborg J Proceedings of the 3 rd Symposium on S trait Crossing [C]. Rotterdam: Balkema, 1994. 54 - 62.
- [4] Curran P, Tilly G. Design and monitoring of the Flintshire Bridge, UK [J]. Structural Engineering International, 1999, 3: 225 - 228.
- [5] Chueng M S, Tad ros G S, Brow n T G, et al. Field monitoring and research on performance of the Confederation Bridge [J]. Canadian Journal of Civil Engineering, 1997, 24 (6): 951 - 962.
- [6] Lau C K, M ak W P N, W ong K Y, et al.S tructural health monitoring of th ree cable -supported bridges in Hong Kong [A]. Chang F K. S tructural Health M onitoring 2000 [C]. Pennsylvania: Technomic Publishing Co, 1999. 450 - 460.
- [7] Natke H G, Tomlinson G R, Yao J T P.Safety evaluation of structures using system identification approaches [A]. Schueller, S hinozuka, Yao. S tructural Safety &Reliability [C]. Rotterdam: Balkema, 1994. 829 - 833.
- [8] Doebling S W, Farrar C R, Prime M B. A summary review of vibration-based damage identification methods [J]. The Shock and Vibration Digest, 1998, 30: 91 - 105.

- [9] Xinran Li, Yingxue Li, Lu Liu. "Research on Mathematical Calculation of Bridge Health Monitoring System based on BIM Model Time History Analysis", 2021 3rd International. Conference on Artificial Intelligence and Advanced Manufacture, 2021.