

IoT Sensor-Based Big Data and Information Systems in Smart Healthcare

Xiang Zhou *

Aberdeen Institute of Data Science and Artificial Intelligence, South China Normal University,
Foshan, 528225, China

* Corresponding Author Email: zhouxiang@m.scnu.edu.cn

Abstract. With the increasing maturity of the Internet of Things (IoT) technology, a new development trend of smart healthcare has been born. This paper, based on the introduction of the current development status, application, and prospects of smart healthcare, mainly focuses on the use of IoT sensors and big data and information systems in smart healthcare and then introduces the relevant technologies involved in wearable devices based on IoT sensors and home environment sensors, as well as the overall operational framework. It also analyzes the case studies of two smart healthcare companies, Sense care and Tencent Cloud, and introduces the smart healthcare technologies they are currently mainly applying. In addition, this report also analyzes the prospects of IoT sensor-based, big data and information systems in the development of smart healthcare, describes some of the current application scenarios and possible areas of application in the future and evaluates the benefits and challenges of their application in the field of smart healthcare.

Keywords: Internet of Things, Smart Healthcare, Artificial Intelligence, Information System.

1. Introduction

Healthcare has always been a fundamental part of the basic quality of life, however, with the growth of the world's population and the increasing demand for high-quality healthcare services, the modern healthcare system is under incrementally great pressure. At the same time, the imbalance in the development of healthcare resources is also intensifying, and it is obvious that advances in healthcare technology are needed to reduce healthcare pressure and provide high-quality healthcare services [1]. Internet of Things (IoT) combined with big data and information systems to promote the transformation of traditional healthcare Smart healthcare is considered as a potential solution to alleviate healthcare pressure [2]. On the one hand, the government strongly supports the promotion of smart healthcare, and in 2006, the Chinese Ministry of Health issued the 2006-2020 National Informatization Development Strategies to make it clear that China should strengthen the construction of healthcare informatization to build and improve a nationwide, fast, and efficient public health information system and enhance the ability of epidemic prevention, monitoring, emergency response, and treatment. Promoting medical service informatization, improving hospital management, and carrying out telemedicine was the strategy's goal. The government encouraged the development of smart healthcare and promoted the deep integration and development of public services and the Internet industry. For nearly 20 years, China's smart healthcare has gone through the stages of HIS, CIS, LIS, and GMIS. On the other hand, technologies such as IoT, Artificial Intelligence (AI), Big Data (BD), and Information Systems (IS) are becoming maturer, which provides a technological foundation for the transformation of traditional healthcare to smart healthcare [3].

Smart healthcare is a new dynamic healthcare model that connects healthcare construction-related aspects in the healthcare service process through the use of cloud computing, big data analytics, AI, and IoT, thereby realizing network interaction, real-time intelligence, and automated interconnectivity between patients and healthcare professionals [4]. The main relevant applications are electronic health information platforms, medical networking, medical big data analysis, telemedicine, artificial intelligence-assisted diagnosis, IoT sensor monitoring devices, automated treatment robots, and so on.

2. Major Technologies Related

Regarding the part of real-time data collection and analysis, it collects the patient's relevant signs and symptoms data through portable wearable sensing devices, and the home environment sensors to collect the relevant data of the patient's living environment in real-time [5]. Portable wearable sensing devices monitor the patient's heart rate, blood oxygen, blood glucose, blood pressure, etc. Equipped with LoRawan and a 5G communication system, the sensors collect data in real time and send back the data collected through the cloud system to the AI and big data analysis system. After the data preprocessing and calculation, the analysis report would be sent to the hospital and patient regularly, which can be uploaded to the mobile device, or medical cloud system to achieve real-time monitoring, data recording, telemedicine, and other functions [6]. In addition, the device has an emergency call function, patients can press the SOS button to call for help. For patients with high blood pressure, heart disease, and other diseases, if the data collected by the sensors deviate too much from the normal fluctuation range, the device will immediately alert the patient and automatically call for emergency assistance. Furthermore, home Indoor sensors help to prevent patients from suffering from most of the diseases affected by the living environment by monitoring the living environment indicators including temperature, humidity, air quality, allergens, noise, light, water, etc., and uploading them to the AI analysis system to analyze the cause of the patient's diseased environment to achieve the patient's aim of recovering from respiratory diseases, eye diseases, and other diseases by providing suggestions to improve the living environment. The sensor also has a built-in gesture recognition camera to monitor patient posture problems, tumble problems, etc.

Building a smart healthcare platform based on sensor technology requires the involvement of numerous technologies, and here are a few of the core technologies related to the main technical aspects. IoT sensor technology, total sensors are built-in different sensor types for different patients, such as temperature sensors, humidity sensors, light sensors, motion sensors, sound sensors, etc., which can be installed as required (see Figure 1). Signal acquisition and conversion technology, analog-to-digital converters (ADCs) is used to convert analog signals collected by sensors into digital signals so that the computer or embedded system can process them [7]. IoT LoRaWan and 5G communication technology, where real-time transmission of sensor data uses LoRaWan or 5G wireless communication technology to transmit the collected data to a cloud data center for storage. Devices that require large amounts of real-time data collection and analysis use 5G transmission technology because of its high transmission rate, high reliability, and low latency. Devices that require only periodic data collection and analysis use LoRaWan transmission technology because of its long-range and low-cost advantages [8]. AI and Machine Learning technologies, which use AI and machine learning algorithms to analyze patient data to provide personalized health assessment, prediction, and recommendations, e.g., a machine learning model can be used to predict the risk of a patient's disease or monitor abnormalities. Data visualization and user interface technology, which uses data visualization tools or develops customized user interfaces to present patient health data in an easy-to-understand manner to doctors and patients to help them better understand and manage their health conditions. Data cloud storage technology uses the powerful storage and computing capabilities provided by the cloud computing platform for data management and analysis. The sensor data collected by artificial intelligence analysis and calculation is stored in databases such as MySQL, Redis, Cassandra, and other technologies such as HDFS distributed file storage [9], where it is implemented by entrusting Google Cloud, Microsoft Azure, and other platforms to upload to the cloud database. Medical information system integration technology integrates the smart medical platform with the medical information system of a hospital or clinic to achieve seamless transmission and sharing of patient data to support doctors' diagnosis and treatment decisions.

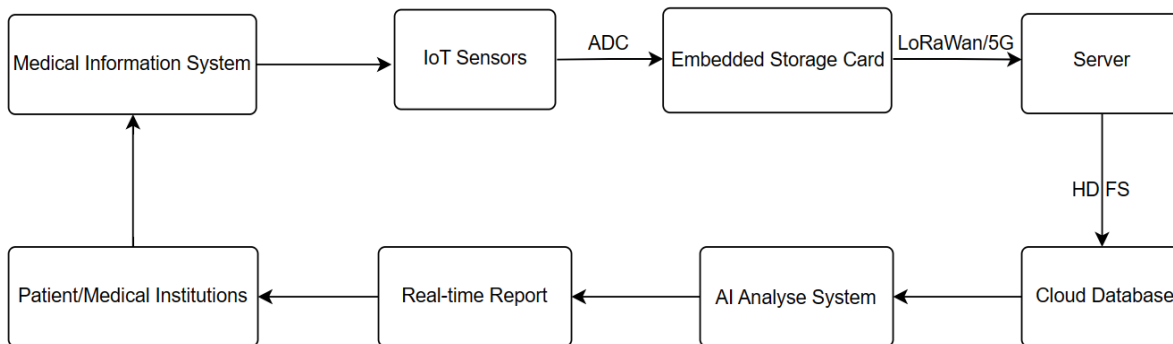

Figure 1. Operation process of IoT sensor monitoring system (Picture credit: Original).

3. Development of WITMED

At present, smart healthcare has realized medical data informatization, medical Internet of Things, remote medical services, medical data cloud platform interoperability, and medical equipment intelligence, experiencing the transformation from traditional healthcare, digital healthcare, and information healthcare to smart healthcare [10]. For individual patients, patient information is stored in the cloud through the cloud platform, and they can contact the doctor online to ask for medical advice and have a preliminary judgment of the condition. A few sensing instruments such as a sleep apnea syndrome detector have been put into application. However, due to the insufficiency of detection equipment and sensor installation, most of the diseases cannot be effectively diagnosed and treated remotely.

At the hospital level, some hospitals have realized the IoT for medical equipment to help manage and distribute medical equipment. Due to the use of medical big data and information systems, the construction of patient disease databases has helped doctors study disease pathogenesis and trace the transmission routes of infectious diseases, which played an important role in the control of China's new crown epidemic. In addition, some medical organizations use big data technology to provide decision-making for medical resource planning.

3.1. SenseCare Smart Hospital

SenseCare Smart Hospital is mainly divided into five scenarios: Smart Diagnosis and Treatment, Smart Medical Care, Smart Management, Smart Medical Research, and Smart Medical Cloud, in which the Smart Diagnosis and Treatment platform are centered on high-performance assisted treatment with AI algorithms and rich image post-processing technology, aiming to improve the effectiveness and efficiency of diagnosis and treatment with the help of AI algorithms. The platform provides full-process intelligent image analysis, covering multiple parts of the body, multiple diseases, and multimodal data, which meets the clinical diagnosis and treatment needs of imaging, liver surgery, thoracic surgery, pathology, orthopedics, radiotherapy, emergency medicine, stroke center, and other departments. At present, the platform has developed more than 20 AI modules, which can be applied to lung, heart coronary, head and neck vascular, liver, orthopedics, pathology, radiotherapy, and other clinical areas with the product advantages of seamless connection to the hospital's Informa ionization system, highly adapting to clinical needs, high concurrency and multi-terminal use, and high data safety and security, which will be applied to various clinical departments in hospitals, third-party testing organizations, physical examination organizations, and other scenarios in the future. Smart Medical Care is in virtue of through AI, computer vision, knowledge mapping, and other technologies to improve the efficiency of patients' medical treatment in three stages before and after the consultation, giving full play to artificial intelligence and computer vision-related technologies to realize AI pre-diagnosis before the consultation to shorten the patient's waiting time, accurately identifying the patient's condition, intelligently matching the experts during the consultation and providing AR navigation to plan the optimal path of medical treatment in real time, and intelligent

follow-up to guide the patient's scientific use of medication after the consultation. The product has advantages of intelligent pre-diagnosis test, intelligent triage navigation, intelligent in-hospital navigation, and intelligent follow-up medication. In the future, this product will be applied to the scenarios of the first visit to the pre-hospital, chronic diseases, and post-operative discharge.

The Smart Medical Research platform realizes the full coverage of scientific research data analysis and mining through the AI big language model and big data technology, which helps researchers accelerate the progress of scientific research on demand and improves the output of scientific research, with the advantages of cross-modal feature fusion, intelligent research project management, intelligent data annotation, and visualization model training. It will be applied to medical research, medical teaching, and other scenarios. The Smart Medical Cloud platform integrates 5G, big data, cloud computing, artificial intelligence, deep learning, and other technologies, which integrates a variety of cloud services, such as 5G teleconsultation, monitoring and analysis of image data, and cloud image health records of patients. With product advantages such as mobile access on all terminals, global monitoring, and intelligent quality control, it will be applied to single hospitals, multi-campus hospitals, and regional healthcare consortiums.

3.2. Tencent Cloud Smart Healthcare

Tencent Cloud Smart Healthcare is mainly divided into seven programs: Smart Medical Cloud, Smart Medical Care, AI Intelligent Auxiliary Diagnosis, Smart Collaboration, Big Data, Cloud Pension, and Internet Hospital. Smart Medical Cloud provides many medical institutions with a comprehensive cloud service solution that integrates IaaS, PaaS, and SaaS, mainly integrating four components: hospital-distributed application clusters, operation and maintenance management, medical video, and security protection to help medical institutions cloudify their basic platforms and save operating costs. It is characterized by high stability, reliability, elasticity, and scalability, and visualized operation. Smart Medical Care includes pre-diagnosis services, in-diagnosis services, post-diagnosis services, online medical care, health management, and medical services. The overall part is in virtue of the Internet, big data, and AI technology to simplify the traditional process of medical care, to improve the accuracy of the matching rate of doctors and patients, and to achieve the seamless integration of the various steps of medical care. Through deep learning, NLP, medical literature, knowledge graph, and other technologies combined with intelligent HIS, ISV, PACS, and other toolboxes, AI intelligent auxiliary diagnosis provides intelligent assistance to the medical service process and improves the work efficiency of experts. Centering on the two aspects of telemedicine and remote teaching, intelligent collaboration realizes telemedicine consultation and remote collaborative teaching through video, voice, graphics, and other means, strengthens the sharing of medical resources and reduces the treatment cost. Big data and cloud pensions can be embedded in Internet hospitals to integrate the overall business architecture. In addition, Tencent Cloud also emphasizes the three deployment modes of medical cloud, which are public cloud, proprietary cloud, and hybrid cloud, representing an innovative attempt of Tencent Cloud in information systems.

4. Prospect and Feasibility Analysis of IoT Sensor-Based, Big Data and Information Systems in Smart Healthcare Development

China's medical industry has gradually promoted the systematization of basic management information since 2014. Due to the national policy level support, the requirements of the Health and Health Commission, the vigorous development of big data and information systems, and the growth of per capita disposable funds, the application scale of China's smart medical industry is currently growing at a growth rate of about 18% per year and is expected to reach about 110 billion yuan in 2024. At present, the smart medical industry involves the field of medical institutions and personal health. The field of health and epidemic prevention and scientific research have broad market prospects. The number of IoT medical devices is growing exponentially, and it is now expected that by 2020, there will be more than 161 million IoT medical devices worldwide [11].

Intelligent medical remote diagnosis and treatment based on IoT sensors provide a relatively free and convenient way to monitor the condition of chronic diseases, rehabilitate patients and pursue health under the premise of not affecting normal life as much as possible. In addition, automatic emergency rescue is provided for high-risk patients to ensure timely rescue. Help residents in backward areas to provide high-quality medical services, reduce patient costs, improve regional medical level and the uneven distribution of medical resources. At the hospital level, the cloud database provides long-term and stable real-time patient data to help doctors diagnose conditions, personalized analysis, and achieve better treatment results. Also, a huge database promotes the progress of achieving research results for scientific researchers.

In the field of medical institutions, the Internet of Things of medical equipment also helps to speed up the process of medical networking, uploading the Internet of Things data to the information system, which is conducive to improving the efficiency of hospital equipment management, reducing the burden of manual management, and effectively solving the problem of insufficient monitoring and management of wards and pharmacies. In the future, under the premise of combining artificial intelligence technology, the full intelligent automation of medical equipment management will be gradually realized, the rapid response and resource allocation technology of medical resources will be improved, and the ability to respond to sudden outbreaks will be enhanced.

In the field of personal treatment, IoT smart medical wearable detection devices and big data analysis information systems are suitable for patients with chronic diseases. For example, patients with obesity, high blood pressure, diabetes, and asthma can wear wearable medical monitoring devices to acquire and transfer the medical data to continuously monitor and analyze their physiological parameters through AI combined with big data platform to achieve the purpose of real-time monitoring and intervention [12]. For certain high-risk patients, such as those with heart disease, the elderly, the disabled, or those with certain genetic conditions, wearable medical monitoring devices can provide timely monitoring and alerting functions to ensure emergency rescue. Indoor household sensors are suitable for patients with respiratory diseases such as asthma and chronic obstructive pulmonary disease. The environmental sensors can monitor indoor air quality, air pollutant concentration, allergens, etc., to diagnose environmental causes more effectively. Surgical rehabilitation patients and elderly people living alone are also suitable for using environmental sensors equipped with posture recognition cameras to timely report patient posture problems, falls, and other events. In addition, the combination of the medical Internet of Things and big data has accelerated the optimization of artificial intelligence diagnosis and treatment models, made up for the lack of resources of traditional medical personnel, reduced the pressure on traditional medical institutions, and improved the efficiency of patient treatment.

In the field of health and epidemic prevention, the construction of cloud databases through big data analysis helps to locate the pathogen of infectious diseases more quickly, track the transmission path, implement artificial precision epidemic prevention, and reduce the transmission rate of infectious diseases effectively. Telemedicine also reduces the infection risk of "human-to-human" offline medical treatment on the premise of ensuring the reliability and authenticity of patient-related monitoring data. Additionally, in the field of scientific research, medical workers collect real-time data through cloud databases and IoT sensors combined with big data and AI-assisted analysis to study the pathogenesis accurately, innovate treatment methods, and promote the birth of scientific research results. The construction of a cloud data information system ensures the sharing of all aspects of information across medical institutions and improves the efficiency of intelligent collaboration.

5. Conclusion

Combined with IoT, artificial intelligence, big data, information systems, and other technologies, smart healthcare has a broad prospect in the fields of personal treatment, medical institutions, scientific research, and health prevention, and has a far-reaching impact on the healthcare industry. However, at the same time, smart healthcare still faces many challenges in future development. First

of all, the security of the data collected by the IoT sensor and the data of the Internet of medicine needs to be safeguarded in real time, which can use blockchain technology to implement distributed data storage and management systems to ensure the security and reliability of data and allow users with permissions to access appropriate data. Besides, the medical networking data sharing process of different data types, the processing of unstructured data, and the adaptation of different data interfaces need to be standardized. It is recommended that the industry or the state introduce relevant policies to unify the provisions to alleviate the difficulty of data organization in the later stage. Also, the subsequent development and maintenance of smart healthcare requires a large amount of capital investment, and private healthcare enterprises in general may have broken capital chain problems and may need government support if necessary. For mass patients, the popularity of smart healthcare is still low, and it still needs gradual transition from traditional healthcare to accept smart healthcare. In addition, the AI consultation model has the risk of misdiagnosis, and researchers should ensure the authenticity and reliability of the collected data, and continuously optimize the AI model to minimize the analysis error rate of AI. In the future, under the premise of adequate optimization of AI models, the smart healthcare industry will gradually develop medical robotics and automation technologies to reduce the risk of human operation and provide more efficient healthcare services. Machine learning will be gradually integrated into the IoT healthcare framework to help healthcare organizations optimize disease prediction and diagnosis, medical image analysis, and drug development based on AI. Meanwhile, The Internet of Nano Things (IoNT) and Tactile Internet (TI) are driving innovation in Healthcare-IoT applications.

References

- [1] Baker, S. B., Xiang, W., & Atkinson, I. (2017). Internet of things for smart healthcare: technologies, challenges, and opportunities. *IEEE Access*, 5, 26521 - 26544.
- [2] Pasluosta, C. F., Gassner, H., Winkler, J., Klucken, J., & Eskofier, B. M. (2010). An emerging era in the management of Parkinson's disease: Wearable technologies and the Internet of Things. *IEEE Journal of Biomedical and Health Informatics*, 19 (6), 1873 - 1881.
- [3] Xiang, G., Zeng, Z., & Shen, Y. (2016). Research on the status quo and development trend of smart medical construction in China. *Chinese Journal of General Medicine*, 19 (24), 2998 - 3000.
- [4] Takao, H., Murayama, Y., Ishibashi, T., et al. (2012). A new support system using a mobile device (smartphone) for diagnostic image display and treatment of stroke. *Stroke*, 43 (1), 236 - 239.
- [5] Solanas, A., Casino, F., Batista, E., et al. (2017). Trends and challenges in smart healthcare research: a journey from data to wisdom. In *2017 IEEE 3rd International Forum on Research and Technologies for Society and Industry (RTSI)* (pp. 1-6). IEEE.
- [6] Wang, X., Li, Q., Ma, C., Zhang, S., Lin, Y., Li, J., & Liu, C. (2023). AI computation in wearable electrocardiogram monitoring. *Journal of Biomedical Engineering*, 40 (6), 1084 - 1092, 1101.
- [7] Choo, K. D., Xu, L., Kim, Y., et al. (2019). Energy-efficient motion-triggered IoT CMOS image sensor with capacitor array-assisted charge-injection SAR ADC. *IEEE Journal of Solid-State Circuits*, 54 (11), 2921 - 2931.
- [8] De Carvalho Silva, J., Rodrigues, J. J. P. C., Alberti, A. M., et al. (2017). LoRaWAN-A low power WAN protocol for Internet of Things: a review and opportunities. In *2017 2nd International Multidisciplinary Conference on Computer and Energy Science (SpliTech)* (pp. 1-6). IEEE.
- [9] Wang, M., & Zhang, Q. (2020). Optimized data storage algorithm of IoT based on cloud computing in distributed system. *Computer Communications*, 157, 124 - 131.
- [10] Mizuhua, Q., & Qian, A. (2019). Literature review of research on the current status and trend of smart medical development. *Chinese Family Medicine*, 22 (3), 366.
- [11] Mavrogiorgou, A., Kiourtis, A., Perakis, K., et al. (2019). IoT in healthcare: achieving interoperability of high-quality data acquired by IoT medical devices. *Sensors*, 19 (9), 1978.
- [12] Jeong, J. S., Han, O., & You, Y. Y. (2016). A design characteristics of smart healthcare system as the IoT application. *Indian Journal of Science and Technology*, 9 (37), 1 - 8.