

# Construction Processes and Strategies of Millau Viaduct

Xiangchen Lin\*

School of Civil Engineering, Tianjin University, Tianjin, China

\*Corresponding author. Email: lxc\_010122@tju.edu.cn

**Abstract.** Millau Viaduct crosses the Tarn Gorge and is one of the highest bridges in the world. More than 20 years after its completion, it still holds the record for the highest pier in the world. It is a shining pearl in the history of human architecture. In this study, the construction processes and strategies of Millau Viaduct are introduced in detail. Results show that after the concrete pier was poured, the bridge deck was pushed forward by applying the jacking from the tail then completed the construction of the long-span bridge. In order to reduce the impact of wind during construction, the construction team improved the construction accuracy by optimizing the bridge model and using satellite positioning. Combined with understanding and perception of the high span and high-risk construction projects such as Millau Viaduct, some methods are put forward to improve the construction technology. These construction methods could be adopted in the future to reduce the risks associated with the project.

**Keywords:** Millau Viaduct; Risks; Construction Processes; Construction Technology.

## 1. Introduction

Located on the A75, one of France's main North-South highways, the Millau Viaduct, 270m above the valley floor, crosses the Tarn Gorge and is one of the highest bridges in the world [1]. It has a steel deck, supported by poles, and seven concrete piers. The entire project took just three years and is a technical masterpiece. The design is bold and elegant, a product of French engineering and British architectural talent.

In the construction process of Millau Viaduct, a relatively new construction method is adopted, which is to make the bridge floor through the roof. This construction method still has hidden dangers.

This study takes Millau Viaduct as an example and introduces its construction method in detail. Besides, it discusses its advantages and disadvantages and provides suggestions for improvement.

## 2. Background

The Millau Viaduct is 2.46 kilometres long and supported by only seven piers, of which Pier No. 2 and Pier No. 3 are 245 meters and 220 meters, respectively. Pier No. 2 is the highest pier in the world (Figure 1). Including the pylons on the piers, it stands 343 meters high at its highest point, 23 meters higher than the famous Eiffel Tower in Paris, France [1]. The total weight of the bridge is 290,000 tons, of which the steel deck alone weighs 36,000 tons.

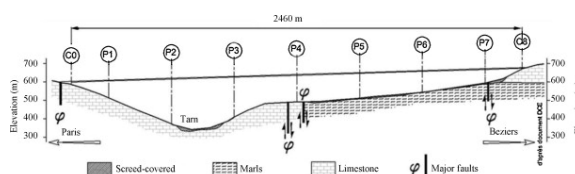

Figure 1. Geological section map [2]

A small town called Millau, just south of the Central Plateau, is the route from Paris to the Mediterranean Sea, and every year countless families pass through it, making their way between the city and the resorts. However, with the River Tarn running between the plain, rolling terrain and limited traffic capacity, Millau is a frequent point of congestion, and it often takes about three hours to cross the route entirely. Therefore, another fast route becomes necessary. There are mountains and valleys here, and building bridges has become an important project for the new highway. After a

decade of design work and more than three years of construction, the Millau Viaduct across the Tarn Valley was completed in 2004, reducing traffic time to just over ten minutes and making it the world's highest bridge.

### 3. Construction progress

Located on the A75, one of France's main North-South highways, the Millau Viaduct, 270m above the valley floor, crosses the Tarn Gorge and is one of the highest Bridges in the world.

#### 3.1 Foundation pit excavation

The first step of construction is excavating the bridge pier foundation pit. It can be seen from the following geological section that the stratum where the bridge is located is mainly marl soil and limestone. Except for a few faults that are not very serious, the geological conditions are generally good, which is conducive to foundation pit excavation and foundation stability. However, one problem with limestone is that it is easy to break and collapse due to its porous nature, which is the main consideration in construction. Work was able to continue after 4,000 cubic meters of rubble were cleared. In addition, pier no. 1 and Pier No. 2 are located beside the river valley and have a large vertical drop, so slope stability should be considered during construction.

As pier no. 2 of Millau Viaduct is one of the highest piers in the world, the land characteristics of Pier No. 6 and Pier No. 2 are different, so the two piers will be mainly analysed here. The diagram below shows the foundation of pier No. 2 and Pier No. 6, respectively. The former is located in the limestone stratum, while the latter is in the marl stratum. Marl is lower in strength than limestone, so the size of the foundation of pier 6 is larger, and the method of expansion at the bottom increases the bearing capacity of the foundation (Figure 2). The same method was applied to several other similar piers.

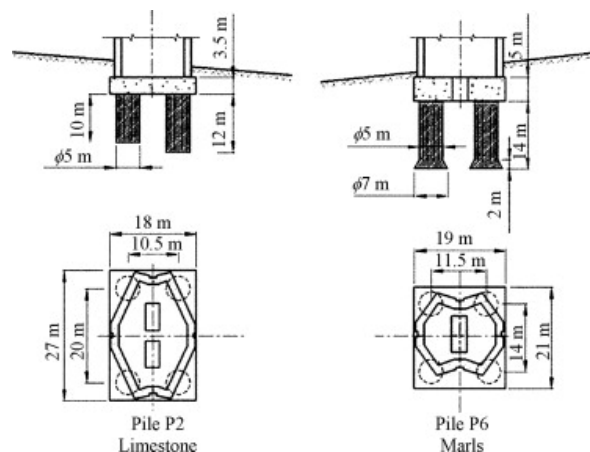

Figure 2. Details of pier foundation [1]

#### 3.2 Concrete bridge pier manufacture

The second step is concrete pier pouring. In December 2001, concrete pouring began. The seven piers consumed 200,000 tons of concrete and 16,000 tons of steel. Among them, the no. 2 bridge pier in the project is about 245 meters high, which is the highest bridge pier in the world at present. The stress analysis and main load are shown in Figure 3.

Because of the different forces applied horizontally and longitudinally, the pier looks different in shape from both directions. Due to the high consumption of concrete, the engineering team built a concrete plant next to the construction site to reduce transportation costs and speed up the construction period. The concrete requirement of this project is high efficiency and early strength. The piers are poured 4 meters high each time, and a layer is poured every three days. The formwork required for pouring concrete is about 15 tons of steel plate. In order to reduce the error, li satellite positioning

system is adopted in the construction process. The total pouring took nearly two years, and in November 2003, the seven piers were finished.

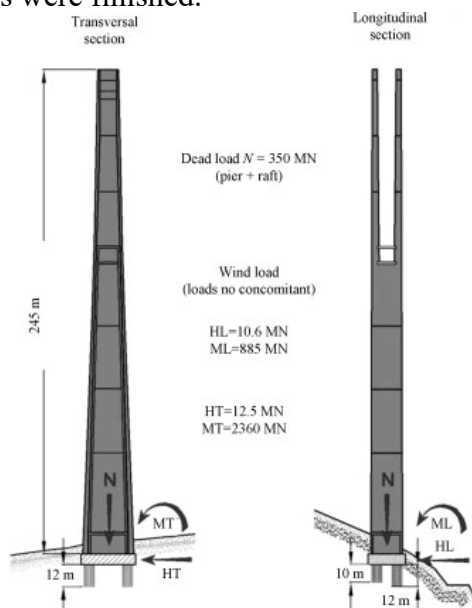

Figure 3. Stress analysis diagram of bridge [1]

### 3.3 Temporary support

The third step is temporary support. Because the project adopts the jacking construction method, the plan is to weld the side of the bridge deck and push forward. However, in the process of bridge deck advancement, the bridge body and top will be deformed by gravity, which would greatly impact the project. In serious cases, the construction quality and safety can be affected. The engineering team solved the problem in two ways: first, the first span and the corresponding pylons at both ends were stretched with cables to ensure that the top did not sag too much. Another is to set up temporary support in the middle of the span to reduce the head and middle of the process of pushing excessive deformation. In addition, temporary support has a positioning function to reduce the error in the jacking process.

### 3.4 Deck construction (welding and pushing)

The fourth step is bridge deck construction, including bridge deck welding and pushing. The 2.5-kilometer deck weighs 36,000 tons and spans the 272-meter-high river. The biggest problem during construction is wind [2]. When the two sides of the bridge body are not closed, the support of the cable has not formed. This height of the bridge body is often due to the wind violently shake. When the wind reaches 70 km/h, all staff have to evacuate the bridge. Winds in the Tarn Valley make traditional construction methods riskier than jacking. Before pushing, a bridge tower is built on both sides and steel cables are pulled, which means that a section of the bridge deck is completed at both ends, and then jacking is carried out. As the deck is pushed up, the deck is welded at the rear (Figure 4).

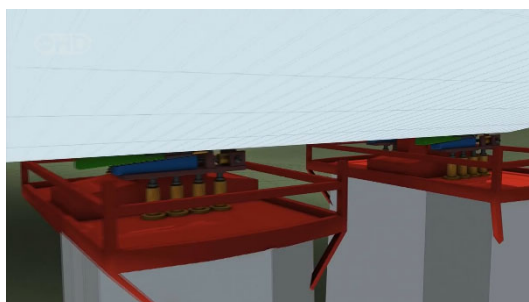

Figure 4. Pushing structure

The deck is docked on the Tarn River, between piers 2 and 3. Using conventional construction methods to push at the end of the bridge would push down the piers and temporary structures, so the engineering team placed ingenious structures on top of the piers [3]. The special structure to push the deck is shown on the right, pushing 60 centimetres each time. Hydraulic jacks provided propulsive force at the top of the piers. The green block moves to the right, the bridge moves to the right, the blue block pulls to the right, the green block falls, the green block moves to the left, the blue block moves to the left, the green block moves to the right, the bridge deck moves to the right, and so on. A Teflon coating is applied between the blue and green squares to reduce friction, and the coating should be kept strong to avoid cracking during construction. The satellite positioning system is also used in bridge deck propulsion to reduce construction errors. The bridge deck was closed in May 2004. The bridge deck is closed over the Tarn River between piers No.2 and No.3. The gap after closure still needs to be welded.

### 3.5 Wire rope tensile

The fifth step is wire rope tensile. After the bridge deck is closed, it can still be seen that the bridge deck is undulating, because the cables have not been assumed and stretched, and the bridge would be undulating under the action of gravity. Engineers, inspired by ancient Egyptian craftsmen, transport the pylon horizontally to its desired position, then use a hydraulic system to lift the pylon and rotate it until it stands upright (Figure 5) [2].



Figure 5. Wire rope

Each cable comprises 91 cables, each of which has an ultimate capacity of about 25,000 tons. Steel cables are bolted to the bridge deck, and tension is applied to the cables to the design value through bolts until the bridge deck is straight.

### 3.6 Paving

The final step is to pave the pavement on the bridge deck. The total weight of asphalt pavement for 2.5 kilometres is about 10,000 tons.

The pavement asphalt of Millau Viaduct is made of a unique material with good skid resistance, heat resistance and stability, which can be widely used in various working conditions [3]. The 60mm thick asphalt material is Made by the Research and Development Department of APPIA based on Base bituminous and SBS (Polymer-Modified Binder).

## 4. Advantages and disadvantages of construction strategies

Through the introduction of the construction method of Millau Viaduct in the third Chapter, we can see that the construction process is very difficult, and the construction team adopted a new jacking method for construction. This construction method is relatively novel, with advantages and disadvantages simultaneously. This section analyzes and discusses the advantages and disadvantages of the construction of the Millau Viaduct.

## **4.1 The advantages**

### **4.1.1. Fast construction speed**

From the groundbreaking in October 2001 to the formal opening in September 2004, the Millau Viaduct was constructed in less than three years, one year earlier than the expected four years [3-4]. The construction process benefited from a variety of means. The construction team built a concrete plant near the construction site, shortening the transportation time of materials to the site.

At the same time, the construction processed reasonable planning of the use of concrete formwork. At the same time, they managed to ensure the quality of construction and construction speed. In addition, the construction team modularized the deck and transported it to the site for welding, transporting materials and welded at the tail end along with pushing. These measures accelerated the construction schedule [5].

### **4.1.2. High construction accuracy**

In the process of construction acceptance, the maximum deflection of the bridge deck measured by the 900 tons load test of 28 trucks is only 26 mm, meeting the requirements of construction acceptance. The construction precision of the Millau Viaduct is so high because the bridge deck is all made of steel, which has good isotropy and high specific strength. Compared with traditional concrete materials, it had a great advantage. The construction team sacrificed the economy for better results. In other words, the builders used steel, which was more expensive than concrete, to ensure a high finish quality and that the bridge would blend in with the surrounding landscape. It did not stand out that much. In addition, the structure of the bridge is highly symmetrical. The cross-section of the bridge deck is symmetrical, and the longitudinal seven piers were evenly divided into eight spans. This improved the bridge body's uniform force, small construction error, bearing capacity and stability. Most importantly, key steps in the construction process, such as pier pouring and deck jacking, were closely monitored during construction. Unlike traditional monitoring methods, the Millau Viaduct used a more advanced satellite positioning system that can meet high construction standards even with such a large span [6-8].

## **4.2 The disadvantages**

### **4.2.1. Teflon soil layer is easily damaged**

On 22 August 2003, the Teflon layer, which was used to reduce friction at the meshing surface, collapsed under heavy pressure. In the design process, only how to reduce the horizontal thrust in the jacking process is considered, and to some extent, the control of normal compressive stress on the slope surface is ignored. Therefore, the gravity of the bridge deck is not controlled, and the Teflon coating bears the weight of the entire bridge deck during construction, which is easy to cause damage to the Teflon coating.

### **4.2.2. Great construction risks**

There is an old saying in China that "a man of art is bold," and although the construction team took various measures to overcome difficulties and complete the construction of the bridge at a high level, the risks involved are still too great to be ignored. Despite the adoption of various methods to reduce risk factors and reasonable construction management, such as requiring the evacuation of all personnel when the wind speed reaches 70 km/h, the construction risk is still very high at 272 meters due to objective factors [1].

## **5. Suggestions for improvement**

The paper points out the various risks that may occur during the construction of the Millau Viaduct. Because of these risks, improvement measures are put forward.

### **5.1 Improvement of Teflon coating for easy damage**

Considering the large weight of the bridge deck, if the traditional rigid connection such as a pulley block is used to reduce the normal stress of Teflon, it is easy to produce stress concentration and then lead to local deformation of the bridge deck, affecting the construction quality and even construction safety. Therefore, the authors propose a kind of after loading device which can bear normal compression stress of Teflon coating without relying on roller.

Inspired by the working principle of the maglev train, the author proposes a device to reduce the force of Teflon coating by the electromagnet. A permanent magnet and electromagnet are arranged around the original slide block [2]. Slide pusher is due to the project itself, so the gap between electromagnet and permanent magnets can be small. Moreover, pushing the deck may produce longitudinal displacement between magnet and magnetic block can change spacing through hydraulic device, producing controllable magnetic force, decreasing the corresponding method to stress, and reducing the damage to the Teflon coating [9-12].

### **5.2 Improvement aimed at reducing the influence of wind on construction quality during construction**

Strong winds characterize the construction of the Milhaud Viaduct. In order to reduce the influence of wind on the bridge, the author believes that this method can be used to reduce the influence of wind on the construction quality.

High pier construction takes the initiative to take windproof measures on the windward side of the temporary windproof structure, used to reduce the wind on the pier template direct force, to ensure the safety of the template, construction personnel and concrete structure safety [2].

The proposed scheme of windproof facilities can ensure the separation of windproof structure and concrete formwork, windproof structure installation ahead of concrete formwork installation, when the concrete formwork is installed, or concrete just completed construction, when the wind comes, can independently bear the damaging effect of wind attack, personnel safety can be more reliable guarantee. The independent windproof structure facilities are designed with advanced concepts and saves investment. Different measures should be taken for different wind speed levels. Windproof facilities are easy to install, relatively simple to operate, less time occupation, and do not damage the main structure [13].

## **6. Conclusion**

This paper introduces the construction significance of Millau Bridge and its construction process in detail. Its advantages and disadvantages are analyzed, and some suggestions for improvement are put forward.

The construction process of the Millau Viaduct can be divided into six steps, foundation pit excavation, concrete bridge pier manufacture, temporary support, deck construction, wire rope tensile, and paving. Among them, the second step (concrete bridge pier manufacture) and the fourth step (deck construction) are the most important steps. Satellite positioning system in construction monitoring is applied.

The key technology of construction lies in how to apply jacking force reasonably and reduce the influence of wind force on construction during bridge construction. Instead of applying a jacking force at the tail, the team used sliding blocks to work together for propulsion. However, the Teflon coating between the sliders is difficult to withstand high pressure and easy to break. Concrete formwork is also large and susceptible to wind.

The authors believe that the pressure of bridge weight on Teflon coating can be reduced by means of magnetic levitation. In addition, the authors believe that the impact on the formwork can be reduced by installing windshields during the construction process.

## References

- [1] S. Doyle, Engineering places: Millau Viaduct, in *Engineering & Technology*, 2021, vol. 16, no. 6, pp. 1-2, doi:10.1049/et.2021.0612.
- [2] M. Buonomo, C. Servant, M. Virlogeux, et al. The design and the construction of the Millau Viaduct, *Steelbridge*, 2004, pp. 165-182.
- [3] F. Schlosser, C. Servant, A. Guilloux, A. Bergere, Millau viaduct geotechnical studies and foundations, *Journal of Rock Mechanics and Geotechnical Engineering*, 2013, vol. 5, no. 3, pp. 243-247
- [4] M. Virlogeux, The Millau cable-stayed bridge. In *Recent Developments in Bridge Engineering*, 2003, (pp. 14-29. CRC Press.
- [5] N.J. Gimsing, C.T. Georgakis, *Cable supported bridges: Concept and design*. John Wiley & Sons. 2011
- [6] M. Filipe, C. Elsa, C. Álvaro, Fl. Olivier, G. Gérard, Ambient and free vibration tests of the Millau Viaduct: Evaluation of alternative processing strategies, *Engineering Structures*, 2012, vol. 45, pp. 372-384, ISSN 0141-0296,
- [7] F. Olard, B. Hérítier, F. Loup, et al. New French standard test method for the design of surfacings on steel deck bridges: case study of the Millau Viaduct. *Road materials and pavement design*, 2005, vol. 6, pp. 515-531.
- [8] C.X. Li, G.S. Zou, Design and construction of Milhaux Viaduct-7 Tower cable-stayed bridge in France, *China academic journal electronic publishing house, World Bridges*, 2005, no. 4, pp. 18-20, U448.27,
- [9] B. Hérítier, F. Olard, F. Loup, et al. Design of a specific bituminous surfacing for the world's highest orthotropic steel deck bridge: France's Millau viaduct. *Transportation research record*, 2005, vol. 1929, no.1, pp. 141-148.
- [10] M. Virlogeux, C. Servant, J.M. Cremer, et al. Millau Viaduct, France. *Structural Engineering International*, 2005, vol. 15, no. 1, pp. 4-7.
- [11] F. Shaarani, A. Ghoul, A. Zeidan. Risk management in construction projects: application to Millau viaduct. 2013.
- [12] J. Han, M. Zeng, J. Song, J. Li, W. Liang, P. Zheng. Innovative Design of Maglev Bridge Support based on TRIZ theory. *Modern Urban Rail Transit*, 2022, no. 7, pp. 50-54.
- [13] B. Lin. Wind-resistant Construction Technology of Bridgein 100km Wind Area of South Xinjiang. *The construction technology*, 2012, vol. 41, no. 5, pp. 65-69.