

Systematic Analysis Based on the Optimal Design of Photovoltaic Inverter Circuit

Guanfang Wang*

College of Electrical and information Engineering, Hunan University, Changsha, China

*Corresponding author: guanfangwang@hnu.edu.cn

Abstract. As a clean and renewable energy source, solar energy is of great significance to reduce greenhouse gas and harmful gas emissions, stabilize energy supply, promote industrial innovation, and help achieve sustainable development and carbon neutrality goals. In this paper, the structure and working principle of photovoltaic cells are introduced, and the characteristics of solar photovoltaic cells and thin film photovoltaic cells are compared and analyzed. Then, the application scenarios of solar photovoltaic power generation and thin film photovoltaic power generation are compared, and the future development direction of photovoltaic cells is prospected. Finally, the structure and working mechanism of the inverter circuit are introduced, some problems in the current photovoltaic inverter circuit are summarized, and then some optimization design of photovoltaic inverter circuit based on the maximum power point tracking technology and leakage current related problems are analyzed, and suggestions on how to optimize the design of photovoltaic inverter circuit are given.

Keywords: Photovoltaic cells; Photovoltaic inverter circuits; Photovoltaic power generation.

1. Introduction

One of the most vital energy sources in contemporary civilization is electricity, which may be produced in a variety of methods, such as hydroelectric power production, thermal power generation, solar power generation, and so forth. In recent years, the depletion problem of global non-renewable energy has become increasingly severe, so photovoltaic power generation has emerged as an effective means to address environmental pollution and the shortage of traditional energy [1]. However, traditional solar power generation faces many challenges, the most important of which is the high dependence on weather conditions, resulting in unstable power generation. In order to solve this problem, scientists are committed to the development of new photovoltaic power generation technology, of which thin film photovoltaic cells because of their low light can still effectively generate electricity and have flexible characteristics of attention. To improve the efficiency of photovoltaic power generation system can be started from the optimization and improvement of photovoltaic cells.

One of the essential parts of a solar power generating system is a photovoltaic inverter circuit, whose job it is to change the direct current produced by photovoltaic cells into alternating current that the grid can use. The need for photovoltaic inverter circuit performance is growing along with the widespread use of solar power production in many application situations. In addition to lowering power loss and increasing overall power generating system efficiency, an ideal solar inverter circuit design also enhances the output power's quality. It is evident that one of the key strategies for raising the solar power generating system's efficiency is to create an ideal photovoltaic inverter circuit.

This paper compares and analyzes the features of solar photovoltaic power generation and thin film photovoltaic power generation based on the structural characteristics of photovoltaic cells and inverter circuits. It also systematically analyzes the best design approach for a photovoltaic inverter circuit, summarizes the applications of both solar and thin film photovoltaic power generation, and anticipates the direction of future developments in photovoltaic power generation technology. It offers theoretical support for the advancement of the photovoltaic sector as well as a reference for future research and development, design, and development of solar power production systems.

2. Comparison of Solar Photovoltaic and Thin-Film Photovoltaic Power Generation

2.1. Photoelectric Effect and Photovoltaic Cells

The fundamental idea behind photovoltaic power generation is the photoelectric effect, which can be defined as follows: when a photon strikes a semiconductor material, the material's electrons absorb the energy from the photon and move into the conduction band, where they split into free electrons and hole pairs. An electric field causes free electrons and hole pairs to flow in opposing directions, creating an electric current. The fundamental building block of solar power generation systems are photovoltaic cells, whose primary function is to directly convert solar light energy into electrical energy. Semiconductors are used in these cells. ever since photovoltaic cells were invented. Crystalline silicon solar cells are now ruling the industry. In recent years, thin-film photovoltaic cells based on CdTe, gallium selenide and copper (CIGS) or amorphous silicon have developed rapidly. It has improved mechanical properties and can be flexibly applied to a variety of scenarios, but it also brings the risk of reduced efficiency [2].

2.2. Solar Photovoltaic Cells

Common types of solar photovoltaic cells are monocrystalline silicon, polysilicon and so on. The internal structure includes: substrate material, doping layer, PN junction, positive electrode and back electrode.

The efficiency of silicon-based solar cells has increased from 15% in 1950 to approximately 28% now. This can be attributed to the silicon band gap's ability to absorb a broad range of solar spectrum, hence optimizing conversion efficiency. The availability of silicon, the second most prevalent material in the Earth's crust, is a major factor in the widespread use of solar cells based on silicon. Due to its semiconductor qualities, silicon is a perfect material for producing electricity from solar energy [3]. However, solar photovoltaic cells (especially monocrystalline silicon cells) require high-purity silicon, the production process is complex and high cost, in addition, solar photovoltaic cells have a strong dependence on direct light, and the conversion efficiency is low in low intensity light.

2.3. Thin-Film Photovoltaic Cells

The internal structure of thin-film photovoltaic cells usually consists of a substrate material, a thin-film semiconductor layer, a transparent conductive layer, a buffer layer, and a back electric layer. Its main materials are various compounds and amorphous silicon. Compared with traditional monocrystalline silicon solar cells, thin-film photovoltaic cells have a thinner light-absorbing layer, typically only a few microns.

Due to the higher cost of crystalline silicon cells, scientists have developed a more economical thin-film photovoltaic cell. Compared with crystalline silicon cells, thin film photovoltaic cells have the advantages of less pollution, wide range of use and low cost [4]. Additionally, it maintains a high power generation efficiency in a low light intensity environment. Nevertheless, thin-film solar cells also have certain issues: their photoelectric conversion efficiency is low (typically ranging from 10% to 15%); The lifespan is relatively short and requires frequent replacement; Some materials (such as cadmium telluride) are toxic.

2.4. Comparative Analysis

Comparative analysis of advantages and disadvantages and application scenarios is shown in table 1.

Table 1. Comparative analysis

Types	Advantages	Disadvantages	Application scenario
Crystalline silicon solar cells	High conversion efficiency Long service life Mature technology Thin and flexible	High cost Single appearance heavy	Large-scale surface power station Rooftop photovoltaic system
Thin film photovoltaic cell	Low light performance is good Low material consumption	Low conversion efficiency Short service life Poor stability	Building photovoltaic integration Mobile devices and wearables

Solar photovoltaics (crystalline silicon photovoltaics) are suitable for scenarios that require high efficiency and large-scale production. Because of its high conversion efficiency and mature production process, crystalline silicon photovoltaic cells have become the mainstream technology of large-scale ground photovoltaic power stations. These power stations are usually built in sunny areas, such as deserts, wastelands, grasslands and so on. With the progress of materials science, the photoelectric conversion efficiency of solar photovoltaic cells (crystalline silicon cells) will be further improved. The application of new materials and advanced manufacturing processes can help improve the efficiency of batteries without significantly increasing the cost. In addition, future research and development will further improve its reliability and stability in harsh environments, so that it is suitable for more application scenarios, such as at sea and in polar regions.

Thin film photovoltaic is widely used in building photovoltaic integration, wearable devices, mobile power and other fields by virtue of its lightweight, flexible and translucent characteristics. Building photovoltaic integration, or BIPV, is a type of solar power generation system that is integrated into the building's structure. This allows it to function as both a building material and a source of photovoltaic electricity. This method considers the building's aesthetics in addition to providing renewable energy. Thin film solar cells need less material and have a very straightforward production process. It is anticipated that the price of thin film batteries may drop even further in the future when new materials—like perovskite materials—are developed. Despite thin film solar cells' currently poor conversion efficiency, if material stability and structure are optimized, the efficiency of these cells will eventually approach that of crystalline silicon cells.

3. Structure and Optimization Design Analysis of Inverter Circuit

3.1. Basic Principle of Inverter Circuit

The inverter circuit plays a vital role in the photovoltaic power generation system. Photovoltaic power generation system is mainly composed of photovoltaic modules, controllers, inverters, batteries and other structures. Solar inverter is the core equipment to achieve power conversion in photovoltaic power generation system [5]. The main function is to convert the direct current generated by the photovoltaic cell into alternating current that can be used by the grid or household. The process consists of the following steps: Firstly, the direct current is transformed into a square wave or pulse-width modulated signal by a high-frequency switch, and then converted into an alternating current approximating a sine wave by a filter circuit. The inverter adjusts the voltage and frequency through a control algorithm which is shown in figure 1.

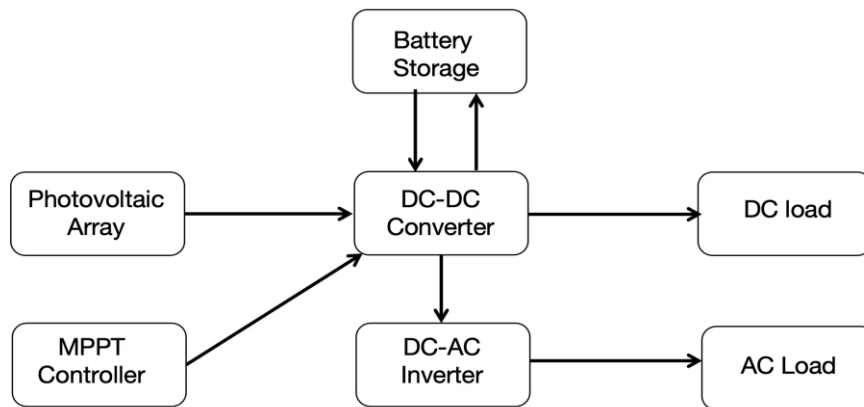

Figure 1. Working process of Solar generation

The following figure 2 is the basic schematic diagram of an inverter circuit simulated by Simulink.

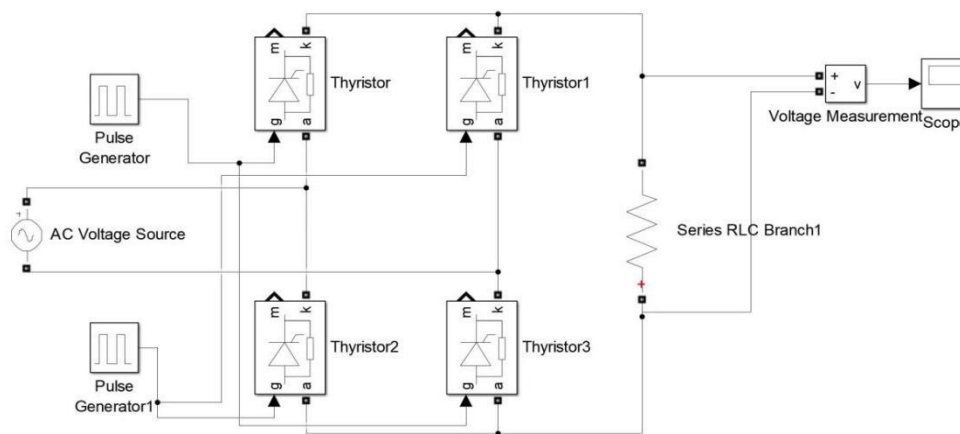

Figure 2. Basic schematic diagram of an inverter circuit

The conversion efficiency of the inverter is an important indicator to measure the performance of the inverter, which can help evaluate the loss of energy during the conversion of direct current to alternating current, and the formula is as follows (where η is the conversion efficiency, $P(\text{out})$ is the actual power provided by the inverter to the load, and $P(\text{in})$ is the input power of the DC power supply): $\eta = (P(\text{out})/P(\text{in})) * 100\%$.

In a photovoltaic inverter circuit, leakage current is another crucial characteristic that is crucial for maintaining system efficiency and safety. Therefore, while creating and refining a photovoltaic inverter circuit, leakage current regulation is an issue that cannot be disregarded. The researchers developed transformerless inverters to address the issue of transformers' increased size, expense, and decreased system efficiency. However, the leakage current in the system has the potential to distort the grid current and lower power quality because there is no current isolation between the inverter and the grid. Consequently, when constructing the photovoltaic inverter circuit, the leakage current value in the transformerless inverter should be minimized [6].

The photovoltaic inverter circuit encounters certain problems in practical application: factors such as temperature and humidity will affect the lifespan of the inverter; High-frequency switching will generate electromagnetic interference and impact power quality. In the future, the application of new materials can be strengthened to enhance system efficiency; It can also be combined with artificial intelligence technology and adaptive technology to achieve more efficient operation; Additionally, the inverter can adopt a modular design to reduce maintenance costs.

3.2. Maximum Power Point Tracking Technology

The goal of Maximum Power Point Tracking (MPPT) in solar power generation systems is to optimize the output power of photovoltaic cells. Photovoltaic cells have an optimal operating point (i.e. maximum power point) under varied environmental variables, such as temperature and light intensity. These parameters also affect the output power of the cells. This technique works based on adjusting the photovoltaic cell pack's operating voltage in real time to maximize solar cell array output power, increase power generation efficiency, and decrease energy loss. Incremental conductivity (IC), perturbation and observation (P&O), constant voltage (CV), and so on are common methods. The P&O method is widely used because of its inherent simplicity and ease of control. However, it is susceptible to fluctuations near the maximum power point, resulting in energy loss and system instability [7]. The intelligent MPPT algorithm combined with artificial intelligence will become a research hotspot in the future.

3.3. The topology of photovoltaic inverter

The topology of photovoltaic inverter refers to the configuration of the internal circuit of the inverter, which directly affects the efficiency, performance and application of the inverter. PV inverter topologies usually include centralized inverters, multilevel inverters, PV grid-connected inverters, and so on. A proper topology needs to be selected based on specific application scenarios and requirements. By optimizing the topology, the dependence on some expensive components can be reduced, thus reducing the cost of materials; The optimized topology can make the system output closer to the standard sine wave AC, reduce the harmonic content, and improve the power quality. Through the optimization of the topology, the inverter will have a better anti-interference ability to reduce the impact of electromagnetic interference (EMI) and voltage fluctuations on the system.

3.4. Optimal Design of Photovoltaic Inverter Circuit

The optimal design of the photovoltaic inverter circuit holds the following significance: Firstly, it can enhance the efficiency of the photovoltaic power generation system and strengthen the stability of the system; Secondly, it can improve power quality and provide more stable alternating current. Additionally, it can also enhance the level of system intelligence. The optimal design of photovoltaic inverter circuit involves many aspects, including the choice of topology structure, the choice of switching devices, the optimization of control strategy, etc., the following will analyze some optimization design cases.

Traditional climbing MPPT methods perform poorly under rapidly changing weather conditions. Therefore, H. A. Sher, K. E. Addoweesh, and K. Al-Haddad combined partial short-circuit currents with climbing disturbances and observation methods [8]. The difference between the short-circuit current and the photovoltaic current is continuously monitored by using current limiting technology to accurately detect changes in weather conditions. Simulation results indicate that the two-stage hybrid MPPT method requires only two sensors for current and voltage measurement, which is low-cost and reliable. Compared to the P&O method, the hybrid MPPT performs better in uniform and dynamic weather conditions.

A new piecewise adaptive step size MPPT method that combines the benefits of partition control MPPT and adaptive step size MPPT was proposed by Y. Xue, S. Sun, J. Fei, and H. Wu [9]. First, the tracking zone is split up into several smaller sections, and each little region is given a unique set of adaptive steps. The experimental findings demonstrate that the suggested strategy can enhance MPPT's dynamic and steady state reaction speed and accuracy. Effective solution to the tracking skip step problem is provided by the partition control algorithm. The long-term use of the MPPT algorithm's short step size algorithm is avoided by employing distinct variable step size algorithms in each small area. Transformerless photovoltaic inverters have garnered significant interest due to their affordability, compact design, and exceptional efficiency.

Transformerless solar inverters do, however, contain common mode leakage currents, which pose a risk to safety and can result in significant electromagnetic interference. Z. Yao, Y. Zhang, and X.

Hu suggested a transformerless grid-connected photoelectric inverter without common mode leakage and penetration issues to address the issues [10]. A multiplier converter plus a double multiplier half-bridge inverter makes up the inverter. The system's efficiency is increased because there is no leakage current and no current passing through the switch's body diode because the input source is grounded and the grid is short-circuited. In addition, because there is no dead time between switches in the same section of the inverter, the waveform quality of the grid current is improved.

When designing a photovoltaic inverter circuit, it is necessary to improve the accuracy and speed of MPPT as much as possible. In the future, MPPT technology should apply more artificial intelligence and machine learning algorithms to optimize traditional algorithms to improve the response speed and accuracy of photovoltaic systems under different environmental conditions. The design of photovoltaic inverter circuit should also consider how to suppress leakage current, the future inverter should adopt advanced leakage current detection and suppression technology, real-time monitoring and adjustment of system status, reduce the impact of leakage current on system safety. Future inverters should also be developed in the direction of low power consumption, by optimizing circuit design and using new materials, not only help to improve system efficiency, but also reduce the probability of leakage current.

4. Conclusions

This paper systematically analyzes the optimal design of the photovoltaic inverter circuit. Firstly, it introduces the structure and principle of solar photovoltaic cells and thin-film photovoltaic cells, and compares their advantages and disadvantages in different application scenarios. Using perovskite solar cells and other cutting-edge technologies to increase the photoelectric conversion efficiency, photovoltaic cell advancements help to increase the efficiency of photovoltaic power production systems. Thin-film photovoltaic technology research has advanced portable equipment, building integration, and other areas while lowering the cost of producing solar cells. The application possibilities for thin-film and solar photovoltaic power generation, as well as prospects, are covered in this study. The fundamental part of the solar power generation system is the photovoltaic inverter circuit, whose ideal design aims to increase power quality and system efficiency. Through the discussion of the structure and basic principle of the inverter circuit, and the analysis of the MPPT technology, this paper summarizes some optimal design cases of the photovoltaic inverter circuit and puts forward a series of optimization suggestions, including the application of new materials, the combination with artificial intelligence, adaptive technology, and the promotion of modular design. With the continuous advancement of photovoltaic power generation technology, photovoltaic inverter circuits will continue to develop in the direction of high efficiency, miniaturization, and intelligence.

References

- [1] Al-Shahri O A, Ismail F B, Hannan M A, et al. Solar photovoltaic energy optimization methods, challenges and issues: A comprehensive review. *Journal of Cleaner Production*, 2021, 284: 125465.
- [2] Pastuszak J, Węgierek P. Photovoltaic cell generations and current research directions for their development. *Materials*, 2022, 15(16): 5542.
- [3] Machín A, Márquez F. Advancements in photovoltaic cell materials: Silicon, Organic, and Perovskite Solar cells. *Materials*, 2024, 17(5): 1165.
- [4] Lin Y, Wu X, Zhi W, et al. Research on Modeling and Simulation of Cd-Te Thin Film Solar Photovoltaic Cells. 2022 2nd International Conference on Electronic Information Technology and Smart Agriculture (ICEITSA). IEEE, 2022: 15-23.
- [5] Qin H, Pan Z, Su J, et al. MPPT Simulation of Cluster Photovoltaic Power Stations for New Power System Planning. 2024 7th International Conference on Energy, Electrical and Power Engineering (CEEPE). IEEE, 2024: 1383-1387.

- [6] Chamarithi P K, Al-Durra A, El-Fouly T H M, et al. A novel three-phase transformerless cascaded multilevel inverter topology for grid-connected solar PV applications. *IEEE Transactions on Industry Applications*, 2021, 57(3): 2285-2297.
- [7] Ullah K, Ishaq M, Tchier F, et al. Fuzzy-based maximum power point tracking (MPPT) control system for photovoltaic power generation system. *Results in Engineering*, 2023, 20: 101466.
- [8] Sher H A, Addoweesh K E, Al-Haddad K. An efficient and cost-effective hybrid MPPT method for a photovoltaic flyback microinverter. *IEEE Transactions on Sustainable Energy*, 2017, 9(3): 1137-1144.
- [9] Xue Y, Sun S, Fei J, et al. A new piecewise adaptive step MPPT algorithm for PV systems. 2017 12th IEEE Conference on Industrial Electronics and Applications (ICIEA). IEEE, 2017: 1652-1656.
- [10] Yao Z, Zhang Y, Hu X. Transformerless grid-connected PV inverter without common mode leakage current and shoot-through problems. *IEEE Transactions on Circuits and Systems II: Express Briefs*, 2020, 67(12): 3257-3261.