

# Application Status and Development Prospect of Liquid Air Energy Storage

Qifan Chen<sup>1, †</sup>, Hang Xu<sup>2, \*, †</sup>

<sup>1</sup>Hefei No.1 High School, Hefei, China

<sup>2</sup>School of Energy and Power Engineering, Jiangsu University, Zhenjiang, China

\*Corresponding author: 3200212193@stmail.ujs.edu.cn

† These authors contribute equally

**Abstract.** The growth of the energy storage sector has garnered increasing attention from nations in recent years. In recent years, the energy storage sector has grown at a rate that has outpaced the expansion of the power sector in terms of real industrial output and application. Due to the obvious growth of renewable energy, there is a sizable market potential for the development of the energy storage industry, which is mostly represented by wind and light. Yet, there is still demand to integrate renewable energy into the grid on a wide scale and run safely and steadily because new energy sources are sometimes available and sometimes not, so they cannot provide a steady, reliable source of power directly by themselves. The aforementioned issues can be successfully resolved through the utilization of technological advancements in energy storage on a grand scale. There are many different ways to store energy, but some of the most common large-scale methods are using batteries, hydroelectric dams, and compressed air. As a novel form of cryogenic technology, liquid air energy storage (LAES) represents a significant step forward in energy storage. It can realize grid-connected new energy consumption, reasonably absorbs low-valley electricity and waste heat resources, and can steadily output various energy sources, including cold, heat, electricity, and industrial gas. This article will discuss the basic principles of LAES and its integrated systems and hope to facilitate future efficient energy storage and renewable energy usage by using LAES technology.

**Keywords:** Liquid Air Energy Storage (LAES), Round- trip Efficiency, Advantages of LAES

## 1. Introduction

The proportion of renewable energy sources used to generate electricity is increasing rapidly, which significantly impacts the energy sector. A straightforward challenge of the rising usage of electricity is the peaks and troughs caused by the fluctuations in the electricity market. Energy storage systems (ESSs) may perform a number of additional helpful functions in addition to balancing the electric grid, including price arbitrage, stabilizing conventional power, and more. So it should come as no surprise that several research initiatives are being carried out to examine the possibilities of cutting-edge technology for electric energy storage. Just two technologies - compressed air energy storage (CAES) and pumped hydro energy storage (PHES) - can presently be recognized as suitable for grid-scale energy storage [1, 2]. Both choices, however, have a considerable disadvantage. Geological characteristics restrict where plants may grow (for instance, the accessibility of an underground cavern for CAES systems). Because the most desirable locations have already been taken, it is impossible to predict any considerable rise in the volume of pumped hydro equipment, especially not in industrialized nations. As a result, people have been working hard to come up with lots of different ways to store electricity so that it can be used later. These ways are effective, affordable, and can be used anywhere. They are also safe for the environment. LAES was born under such circumstances.

Outstanding benefits of LAES include its large-scale, clean, and low-carbon energy storage, as well as its longevity, safety, and independence from geographic circumstances. Areas such as startups, distributed energy, microgrids, and integrated energy services have advantages.

From a technological perspective, in the process of the storage stage, the system drives the compressor to compress the ambient air from storage while storing the heat of compression at night using renewable electric energy or a power grid.

During the release process of energy, after the cryogenic pump pressurizes the liquid air, the regenerator stores and releases cold energy. And the air turbine is powered by high-pressure, high-temperature gas that is produced by the regenerator after the air has been heated with compressed heat (additional solar energy or low-temperature waste heat in the factory). Rotating to carry out tasks, power the generator, and connect to the grid. Additionally, the system's extra compression heat energy may be split between providing domestic hot water or winter heating and operating an absorption refrigeration unit to provide air conditioning cold water for summer cooling.

## **2. Advantages of the LAES system compared to other ESSs**

### **2.1. Less geographic limitation**

Compared with other storage technology, the significant advantage of LAES is it has fewer geographic limitations. Pumped hydro energy storage (PHES), is a popular storage technique with a large energy storage capacity which is the most obvious advantage of PHES. However, the disadvantage of PHES is obvious. The running of PHES should be based on lakes and rivers, and it is very geographically limited. The flexibility of PHES is too low, which means that PHES will not be used somewhere that really needs a system to store energy. CAES is a system that possesses similar principles to LAES, but the basic disadvantage of CAES is that it has many geographic limitations. The low energy density of CAES results in CAES needing a huge volume to store air for energy storage. Therefore, building a huge tank for storing air is very expensive. For economic reasons, it is not sagacious to build a huge tank to store air. In general, people build CAES systems in caves rather than a tank. In contrast, there are fewer geographic limitations for LAES. The major difference between LAES and CAES is that LAES has relatively high energy density, which means that LAES only need a relatively small storage volume. The small storage volume allows people to build a tank for storing air from an economic point of view. That is the benefit that brings less geographic limitation.

### **2.2. Long Duration and Mature Development**

An essential criteria for an ESS is the period of usage. Overall, the LAES system has a very long service life, ranging from 20 years to 40 years. According to the Energy Storage Association, the LAES system's service life would be about 20 - 40 years [3]. On the other hand, as for the CRYO Battery developed by Sumitomo Heavy Industries (SHI) and Highview Power Partner, the service life of this LAES system can be even higher.

The low maturity of technology will bring much indeterminacy to users of technology. With the development of new technology, the technology will be more and more advanced, and indeterminacy will be less and less. In 1995, NASA (National Aeronautics and Space Administration) mentioned the term TRL(Technology Readiness Level) to represent the maturity of a technology. TRL has 9 levels to represent the maturity of a technology. Level 1 means most immature, and level 9 represents most advanced. As of 2021, the TRL of LAES is 7-8, which means it is relatively advanced.

### **2.3. Cost-effective for energy storage**

The cost of new technology is an important way to measure if it is cost-performance. Table 1 illustrates the average costs of LAES systems vs. Lithium-ion battery systems by years.

The unit of average costs is \$/MWh with an exchange rate that one euro is equal to 1.02 USD. The lithium-ion battery system is also an important energy storage way. The data from Table 1 demonstrate that the trend of cost of LAES is declining, and data in 2022 is too big and considered an outlier. From 2017 to 2021, the cost of the LAES system reduces by about half, which is huge progress for LAES. According to President and Chief Executive Javier Cavada, the LAES system is

estimated to have a reduced cost of \$50/MWh by 2029 [4,8]. Overall, the future of LAES is very bright, and the cheap cost will be a significant advantage to LAES.

**Table 1.** Average costs of LAES systems vs. Lithium-Ion Battery systems by years. Data from previous research [5- 11]

Year	LAES systems - \$/MWh	Lithium-ion Battery systems- \$/MWh
2016	NA.	267-561
2017	220-280	NA.
2018	NA.	NA.
2019	140	NA.
2020	163	NA.
2021	116-142	136-286
2022	182.6-219.8	NA.

Furthermore, the charging device of LAES uses peak-off electricity and excess industrial electricity to keep the working of LAES. Thus, the electricity cost of LAES has been reduced substantially.

### 2.4. High Energy Density

Energy density is a very important part of the introduction of a new storage technology because it is related to the storage volume of the technology. With the same volume, higher energy storage and transportation efficiency could be achieved by the utilization of a system with higher energy density. The main factor that affects the energy density of technology is the structure of the ESS itself and the volume of the ESS. The basic reason why LAES has relatively high energy density is that the system exerts high pressure on air and liquefies air. Energy density can be represented by two units, Mega joule per kilogram (MJ/kg) and megajoule per liter (MJ/L). Figure 1 is a selected energy densities table; and the x-axis represents MJ/kg, and the y-axis represents MJ/L. The red point represents the changing of energy density as the changing of the pressure that is exerted on the material. For example, natural gas, natural gas under 250 bar, liquid natural gas. As the pressure exerts on the natural gas to higher and higher, it is obvious that the energy density of natural gas is to be higher and higher. Similarly, the reason why LAES has high pressure is that there is a high pressure exerted on the air of the LAES system. The running process of LAES and CAES are similar because they have a similar principle which is to compress air. However, the energy density of LAES is much higher than CAES. The energy density of LAES is 10 times higher than CAES, the huge difference in energy density between LAES and CAES makes sure LAES will have more cost performance than CAES, and high energy density will be an obvious advantage of LAES.

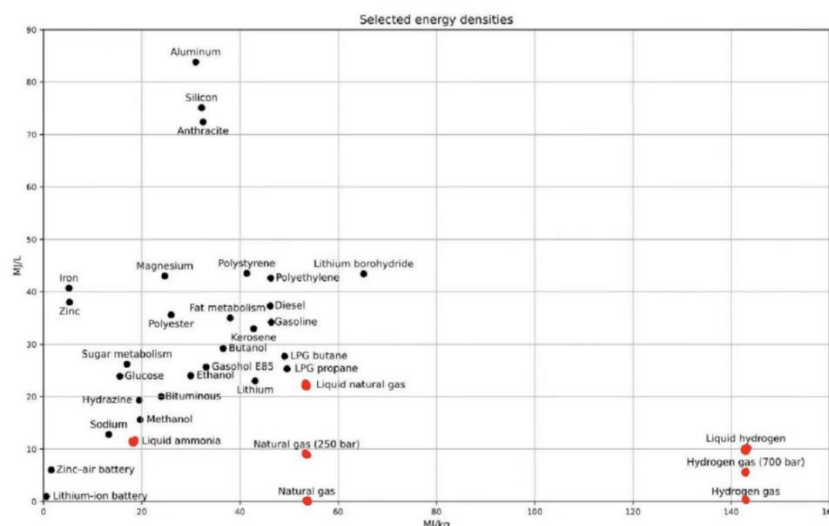

**Figure 1.** Selected Energy Density Table [12]

Table 2 compares the following technologies: PHSE, CAES, PTES, and LAES. According to Fig. 2, LAES has the highest rank in terms of energy density. High energy density is a unique advantage of LAES, among others. However, LAES also has some disadvantages of LAES. The volume of the tanks of LAES is relatively lower than the volume of other compressed storage technology, such as CAES. Despite having an energy density more than ten times greater than CAES, LAES has storage space for energy that is around half that of CAES. Thus, further research is necessary to improve the storage volume of LAES.

**Table 2.** A comparison of the energy density of four major mechanical storage technologies [3]

	PHES	CAES	PTES	LAES
Energy Density (Wh/L)	0.5 ~2	0.5~20	10~100	50~200

### 3. Overview of the LAES system

#### 3.1. LAES system working mechanism

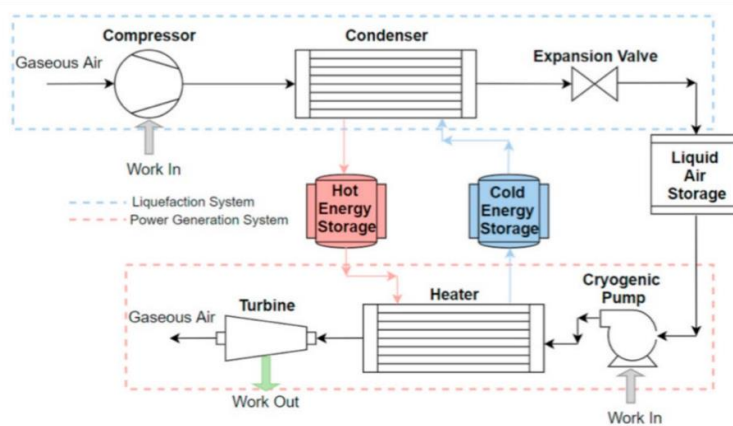

**Figure 2.** Flowchart showing the fundamental LAES system's operation [13].

Figure 2 above shows the process for a basic LAES system. The process in the blue dashed box is the liquefaction or charging process. The red dashed box represents the power generation process. Black arrows show the entire cycle of the system. Air will first be pumped into the compressor from the atmosphere, leaving under high pressure and high-temperature conditions. The hot, high-pressure gas is then passed to a heat exchanger where the temperature of the gas will drop to or below about  $-190^{\circ}\text{C}$  (at a given high pressure, the air will be in liquid form). After that, the expansion valve will further cool the liquid (usually to  $-196^{\circ}\text{C}$ ) and expand it until the final pressure is close to atmospheric. The liquid air will then be stored for future use. During the liquefaction process, the heat removed during the compression process is stored and further used in the power generation system. Also, during the final stages of the liquefaction cycle, some of the liquid air will evaporate from the expansion valve and form a liquid-gas mixture. Therefore, finding the optimal liquefaction cycle configuration is important in improving the LAES system efficiency.

For power generation systems, liquid air will be pumped into the heater by cryopumps, where the liquid is vaporized and superheated (usually 700 times the liquid). The heat used to drive the heater refers to the heat generated and stored during the compression process. The hot gas will then be used to drive turbines and evaporators to generate electricity and cooling. To increase the efficiency of the LAES system, the heating and expansion process is usually repeated multiple times. In addition, cold energy will also be stored from the expansion process and used in future liquefaction cycles.

As shown in Figure 3 below, three phases may be used to further categorize the standard LAES system operating procedure. The first step is the charging procedure, which uses surplus electricity to deal with the air. Step two represents the procedure of storage. The liquefied air created in step one will be kept in an insulated tank at a pressure close to atmospheric pressure. The third stage, known as the discharge process, recovers energy by handling it through several measures in order to generate

electricity. In addition, step 2 stores heat from the air compression process and high-grade cold energy from reheating process. In stages 3 and 1, respectively, the heat and cold energy can be recognized to be employed to boost power output and cut down on energy usage in the liquefaction process.

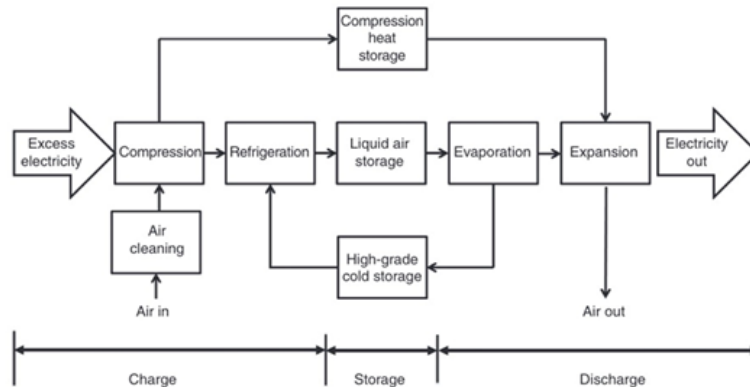
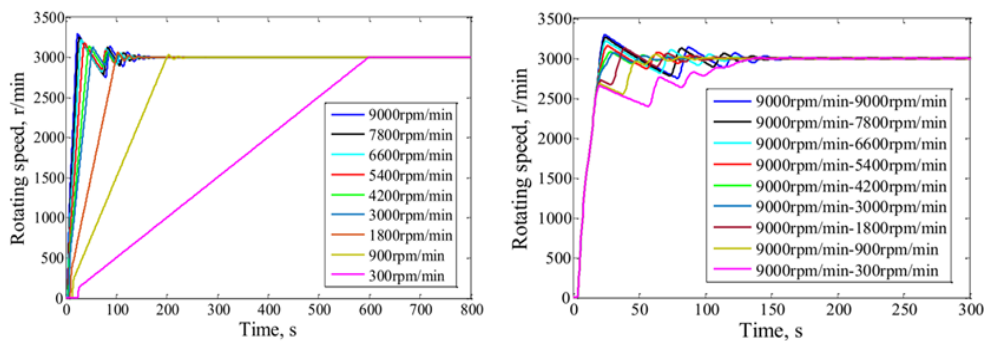

**Figure 3.** A scheme of the LAES system [14]

Round-trip efficiency, as a crucial component of efficiency, may be determined by dividing the total quantity of work input in storage mode by the total amount of work generated in recovery mode. The result for round-trip efficiency was found to be 54% [15], which is a bit low. Therefore, low round-trip efficiency remains a key challenge for LAES technology in industrial applications.

### 3.2. Electricity generation speed of LAES system

In the process of electricity generation, the liquid gas is heated, and the gas drives the turbine to generate electricity. The key to a rapid generation of electricity in a system is a long period of time in which the liquid heated system can operate smoothly, which would enable the gas vaporization to be continuously fed into the generator to generate electricity.



**Figure 4.** The rotating speed vs. time under different startup speeds (left), and The rotating speed vs. time under different segmented startup schemes (right) [16].

Figure 4 above demonstrates how long can the rotation speed of the expander become stable under a specific startup speed or a frequency-modulation scheme. The figure on the right is the system has been segmented with frequency modulation equipment. According to the previous report, the quickest startup time is experimented to be 145s under 9000rpm/min – 3000rpm/min segmented startup scheme, which is decent for a grid-scale ESS [3 in TM][16]. However, further study is needed for the adjustment system of the turbine rotation under the safety condition (the safe overspeed ratio is calculated to be less than 110% [16]).

## 4. LAES system integration with other systems

### 4.1. Combining LAES with gas turbine peaking plants

By combining the peak shaving equipment, it is feasible to take advantage of the waste heat generated, increasing overall efficiency and peak shaving capacity [14]. Incorporating both processes

allows for the distribution of dry ice while still capturing CO<sub>2</sub> with more efficiency. Figure 5 depicts the cycle's flow diagram, which works as follows: The air separation and liquefaction (ASU) unit, which creates liquid nitrogen and oxygen during off-peak hours, is powered by extra energy produced by the base load, while the remainder of the system is powered by the high-pressure turbine (HT) off, which is utilized to generate power in the system. In order to help combustion in the combustor (B) during peak hours, a cryogenic and low-pressure turbine (LT) maintains extra pressure while liquid nitrogen and oxygen are retained in pressurized containers. The created liquid nitrogen also functions as a form of energy storage. Throughout peak hours, compressor C1 brings natural gas up to operating pressure. In the following time, working fluid is combined with oxygen in the combustor (B), resulting in the production of a flue gas that is made up of CO<sub>2</sub> and H<sub>2</sub>O with high temperature and high pressure. Temperatures produced in this way are too high for a gas turbine (GT). For the purpose of lowering these temperatures, a suitable quantity of helium is added to the flue gas before it is passed through the generator (G) and into the GT, where it is used to generate electricity. It should be noted that the helium gas is cycled throughout the system rather than being consumed; see figure5. The helium-containing flue gas experiences heat exchangers 1 (HE1), 2 (HE2), and 3 (HE3) in order to reuse the waste heat; see Figure 5. The condenser (WS) removes the vapor from the flue gas during heat recovery, whereas the condenser (CS) solidifies the CO<sub>2</sub>, which has a triple point of 571.8 kPa (5.718 bar) and 56.6 °C, and removes it as dry ice during the process. As a result, when the CO<sub>2</sub> has been removed, all that is left is helium in the flue gas stream. Prior to returning to the combustion chamber, the helium stream undergoes more cooling in HE3, compression to working pressure in compressor C2, and then heat exchanging in HE2 and HE1.

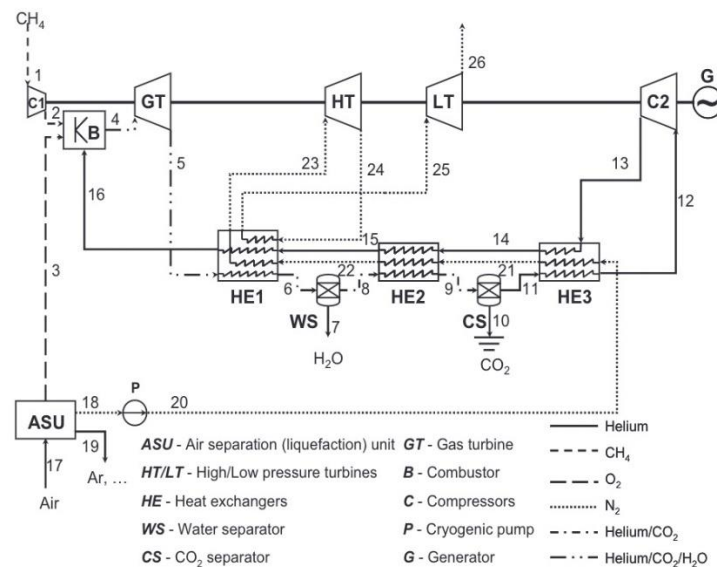

**Figure 5.** Process flow for a peaking power system using a combination of gas turbines and LAES [14]

A cryogenic pump (P) raises liquid nitrogen pressure to its operating level when the nitrogen flow begins in the cryogenic storage tank. After being heated through HE3, HE2, and HE1 in that order, the high-pressure nitrogen is expanded separately through HT and LT, producing electricity in turn. Between the two expansion stages, a heater called the heat exchanger 1 (HE1) is employed.

As may be deduced from the foregoing, the integrated system consists of an open-bottoming nitrogen direct expansion cycle and a closed-loop topping Brayton cycle [4] using He/CO<sub>2</sub>/H<sub>2</sub>O as the working fluid. The bottoming Brayton cycle is 18/20/21/22/23/24/25/26, whereas the peaks may be found as 4/5/6/8/9/11/12/13/14/15/16. The two cycles together are what generate power during peak hours. The ASU creates pure oxygen, which is then used to burn natural gas. The gist of it is that helium is recirculated and used to regulate the intake temperature of the turbine. The real energy carrier of the off-peak power is nitrogen, which serves as the open cycle's working fluid.

With such an integrated system, the CO<sub>2</sub> in the flue gas is completely absorbed, while the ideal energy storage efficiency is close to 70%.

#### 4.2. LAES integrated with nuclear power plants

Nuclear power stations frequently need to be down hauled in order to balance supply and demand during off-peak hours, particularly when the installation surpasses the base load requirement. In addition to raising the price of energy, the partial-load operation has a negative impact on the safety of the plants. A viable option for effective time-shifting of power production is the combination of the stations with LAES. The flowchart of this integration is shown in Figure 6. The integrated system is made up of both a LAES subsystem and a subsystem for nuclear power plants. The integrated system in the subsystem of the plant is comparable to a conventional pressurized hydropower station. The main distinction is the presence of two three-way valves in the secondary circuit. This circuit makes the working fluid able to get into either the heat exchanger 4 to overheat high-pressure air in LAES subsystems or the turbine. The LAES subsystem consists of the energy extraction unit in the lower right corner of Figure 6 and the air liquefaction unit on the left. Based on the system, an integrated system may have three modes of operation.

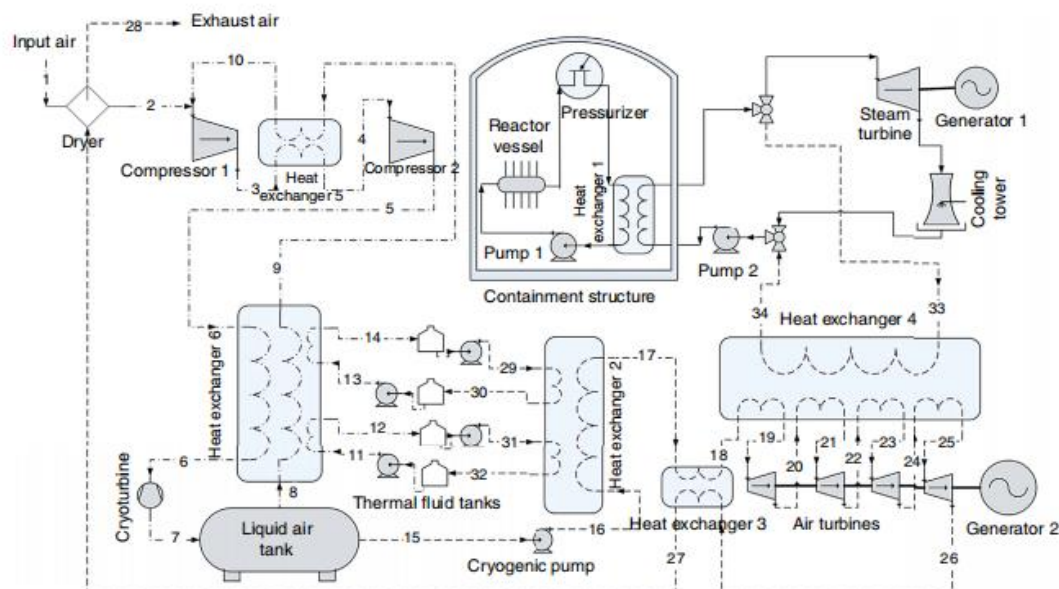

**Figure 6.** LAES integrated with a nuclear power plant [14]

The needs of the end user are as described below:

**Energy storage method:** During off-peak hours, the power plant operates as its traditional procedure. The steam turbine is driven to create electricity, as well as the air liquefaction device is driven with excessive power to make liquid air.

**Energy Release Mode:** The system can be activated to provide extra power during peak hours when demand exceeds the plant's rated capacity.

**Conventional mode:** Whenever supply and demand are roughly equal, the energy extraction mechanism and the air liquefaction are out of action, allowing the energy to function conventionally and power the turbine to supply electricity.

#### 4.3. LAES integrated with the solar power plants

Extra heat production, such as those produced by commercial operations or renewable solar radiation, can increase round-trip performance and minimize the investment costs of the LAES system. This part looks at how solar thermal is used in big concentrated solar power (CSP) facilities. Figure 7 depicts the hybrid system with combined LAES and solar thermal power generation.

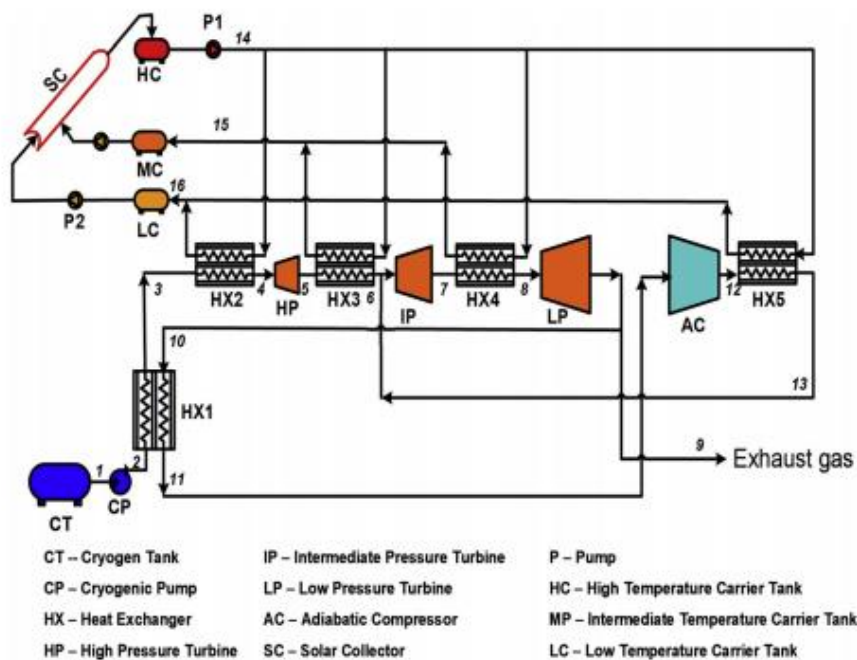

Figure 7. Combining LAES with a solar power system [14]

#### 4.4. Combining LAES with liquefied natural gas regasification

Additionally, LAES can be considered to combine liquefied natural gas (LNG) regasification facilities for the aim of benefiting from waste cooling at the time of air liquefaction [14]. The LNG import terminal is quite important given the substantial volume of LNG storage. In order to regasify LNG, a portion of natural gas is often heated and combusted with seawater, which results in the accumulation of waste of cold and combustible natural gas in LNG. The generated cold air may be sent into air liquefaction, which can cut energy use by up to two-thirds, provided the lye is co-placed at the LNG endpoints as well as adopts air instead of saltwater for the purpose of creating heat which is needed in LNG regasification. Many nitrogen liquefiers are now located at the parts near the LNG import in several countries, and they employ this refrigeration to cut power usage. The only hurdle that must be addressed is lowering the capital cost of such funds through the use of the combined system.

#### 4.5. Combining LAES with decentralized energy systems

Up until now, the majority of research has focused on patent-like (called benchmark LAES) with operating pressure ranges that are identical to those in the patent. In recent research, 1e21 MPa, at the extreme of the working pressure, was explored as a larger charging pressure range [17].

According to the investigation, the baseline return is capable of achieving the aforementioned electrical round-trip efficiency (eRTE) of 60% at the point of 19 MPa. Yet, baseline LAES brings significant extra heat, particularly happens at the point of w1 MPa. In addition to evaluating performance, baseline LAES measures surplus heat, which produces substantial eRTE, approaching an utmost - 62% at the point of w4 MPa. For the aforementioned reasons, the integrated LAES system can be recommended in the process of generating energy, cooling and so on.

### 5. Conclusion

Depending on this study about LAES, we hold an idea that LAES will be a main storage technology in the future, it will fit to almost all terrain all over the world. Just like it was written in the introduction part of the paper, there is almost no geographic limitation for LAES, and that's the most attractive advantage of LAES. The second essential advantage of LAES is green, clean, and non-pollution. Therefore, LAES is in line with the current global development trend. This means that

LAES will conform to the policies of each country in the future. In addition to the economic advantages of policies, the most important is for the environment.

Efficiency is a significant point for storage technology. Although the efficiency of LAES is only 55.4%, the efficiency of LAES can be improved when LAES work with other power station, such as nuclear power station and solar power station. In the future, with energy problem, and in the situation that all most every government limit energy consumption, some factor, such as the efficiency of electricity storage, geographic fitness, and pollution discharge, will be very important. In this situation, it is important to meet the government's requirement for storage technology. After many years, the LAES will be advanced, and LAES will become promising technologies for energy storage applications.

## Reference

- [1] Evans A, Strezov V, Evans T J. Assessment of utility energy storage options for increased renewable energy penetration[J]. *Renewable and Sustainable Energy Reviews*, 2012, 16(6): 4141-4147.
- [2] Rodrigues E M G, Godina R, Santos S F, et al. ESSs supporting increased penetration of renewables in islanded systems[J]. *Energy*, 2014, 75: 265-280.
- [3] Vecchi A, Li Y, Ding Y, et al. Liquid air energy storage (LAES): A review on technology state-of-the-art, integration pathways and future perspectives[J]. *Advances in Applied Energy*, 2021, 3: 100047.
- [4] O'Callaghan O, Donnellan P. Liquid air ESSs: A review[J]. *Renewable and Sustainable Energy Reviews*, 2021, 146: 111113.
- [5] Collins, L. GWh-scale liquid-air battery offers storage at half cost of lithium. 2019. <https://www.rechargenews.com/transition/gwh-scale-liquid-air-battery-offers-storage-at-half-cost-of-lithium/2-1-629164>
- [6] Lazard's levelized cost of storage analysis- version 2.0. (p. 11) [R]. 2016. Retrieved from: <https://www.lazard.com/media/438042/lazard-levelized-cost-of-storage-v20.pdf>
- [7] Lazard's levelized cost of storage analysis- version 7.0. (p. 13) [R]. 2019. Retrieved from: <https://www.lazard.com/media/451882/lazards-levelized-cost-of-storage--version-70-vf.pdf>
- [8] Nelmes, S. Liquid air energy storage (LAES) (p. 19) [R]. 2017. Retrieved from: [https://warwick.ac.uk/fac/sci/eng/research/grouplist/electricalpower/images/newsnews/hies2017/presentations/hies2017\\_highview.pdf](https://warwick.ac.uk/fac/sci/eng/research/grouplist/electricalpower/images/newsnews/hies2017/presentations/hies2017_highview.pdf)
- [9] Brownlee, J. How to Decompose Time Series Data into Trend and Seasonality. 2017. Retrieved date: 30 July 2022, from <https://machinelearningmastery.com/decompose-time-series-data-trend-seasonality/>
- [10] Tafone A, Ding Y, Li Y, et al. Levelised Cost of Storage (LCOS) analysis of liquid air ESS integrated with Organic Rankine Cycle[J]. *Energy*, 2020, 198: 117275.
- [11] Cui S, He Q, Liu Y, et al. Techno-economic analysis of multi-generation liquid air ESS[J]. *Applied Thermal Engineering*, 2021, 198: 117511.
- [12] Dial, S. A plot of selected energy densities (excluding oxidizers). 2018. Retrieved 6 August 2022, from [https://en.m.wikipedia.org/wiki/Energy\\_density](https://en.m.wikipedia.org/wiki/Energy_density)
- [13] O'Callaghan O, Donnellan P. Liquid air ESSs: A review[J]. *Renewable and Sustainable Energy Reviews*, 2021, 146: 111113.
- [14] Ding Y, Li Y, Tong L, et al. Liquid air energy storage[M]. *Storing energy*. Elsevier, 2022: 191-205.
- [15] Guizzi G L, Manno M, Tolomei L M, et al. Thermodynamic analysis of a liquid air ESS[J]. *Energy*, 2015, 93: 1639-1647..
- [16] Cui S, Lu C, Shi X, et al. Numerical investigation of dynamic characteristics for expansion power generation system of liquefied air energy storage[J]. *Energy*, 2021, 226: 120372.
- [17] She X, Zhang T, Peng X, et al. Liquid air energy storage for decentralized micro energy networks with combined cooling, heating, hot water and power supply[J]. *Journal of Thermal Science*, 2021, 30(1): 1-17.