

Gain Modeling and Numerical Simulation of Fiber Amplifier

Yuzhi Huang^{1,*}, Tianyi Wang²

¹Beijing University of Posts and Telecommunications, Beijing, China

²Beijing University of Posts and Telecommunications, Beijing, China

*Corresponding author: 2020213096@bupt. cn

Abstract: As optical communication technology has been developing fast these years, its application in S-band has been valued by people, especially in the field of WDM/DWDM. The energy structure in Tm³⁺ exist the transition which can meet the S-band and S+-band. Although the energy structure of ions are very complex, the fiber amplifier is an important device for the S+-band optical amplification. And its research will be very significant for further broadening the optical communication bandwidth. Fiber amplifiers have become a new hot spot for optical fiber communication devices. This paper mainly do analysis, simulation and comparison about the semiconductor laser multi-core pigtail outputting light field intensity, as well as the outputting light field intensity distribution of LD multi-core pigtail single-lens and dual-lens coupled. This paper analyzes fiber amplifier performance based on the rate equation, transfer equation and simulations.

Keyword: Fiber amplifier, Numerical simulation, Application

1. Introduction

The history of fiber amplifiers is over 100 years until now. Since 1972, Raman first discovered Raman gain in the experiment of Raman fiber amplifier, the research of the fiber amplifier has entered an era of rapid development. In the mid-1980s, the University of Southampton made a breakthrough in Er³⁺ fiber, it is the first successful fiber amplifier in the world, making the rare earth doped fiber amplifier more practical and shows a very attractive application prospect. Due to the successful large-scale commercial application of fiber amplifiers and the continuous demand for the capacity of optical fiber communication systems, the communication window of fiber communication systems is bound to expand to S-band. As early as the early 1960s, a large number of experiments were finished to study effect of ions (Tm³⁺). In 1982, B. M. Antipenk first obtained the 1.47 μm band transition that can be used for optical fiber communication, which opened the prelude of the research of doped fiber amplifiers by researchers in various countries. Then in 1989, J. Y. Allain used a 676 nm hydrogen ion laser as the pump source to pump Tm³⁺ multimode fiber. A laser output of 1.47 m was obtained. At last, in 1992, NTT company of Japan first proposed the pumping mode of energy upconversion, which solved the second problem of the fiber amplifier. It promoted the development of dopant fiber amplifier. After that, NTT company, NEC company, Alcatel company, and other scientific research institutions continued to do a lot of experimental research. They focused on researching doped fiber amplifiers so that doped fiber amplifiers have been able to achieve 40% power conversion efficiency.

As This paper already got a lot of achievements in theoretical, the recent research direction tends to the research of materials. The main substrates are fluoride glass, quartz glass, and fluoride glass. Fluoride glass is a widely used matrix material nowadays. Still, its chemical stability and mechanical properties are poor, and the preparation process is complex, which makes it difficult for the existing widely used quartz glass optical fiber to achieve physical docking. Quartz glass has excellent physical properties and is easy to process. It can be well connected with optical fibers that have been widely used. However, the doped quartz fiber also has problems such as large phonon energy, and easy formation of ion fragmentation, which is not conducive to optical amplification.

The article is aimed to show the Gain modeling and numerical simulation of the fiber amplifiers. An optical amplifier is significant in optical fiber communication and is also indispensable in optical fiber communication components. Among all fiber amplifiers, TDFA is an important kind. With its wide gain bandwidth, low noise figure and excellent power stability, it was favored by scientists.

In the front part of the paper, This paper introduced the general situation of TDFA according to the logic of development history and the latest development. In the later part of the article, This paper will show the gain modeling and numerical simulation of TDFA through the experimental process and charts. In the future, TFDA will be applied to develop optical fiber communication technology for the S-band. It is of great practical significance and function to improve the system communication capacity and upgrade the optical fiber communication system.

2. Principle

Tm is the 69th element in the periodic table of elements, and its atomic electronic structure is $1s^2 2s^2 2p^6 3s^2 3p^6 3d^{10} 4s^2 4p^6 4d^{10} 4f^{13} 5s^2 5p^6 6s^2$. Its relative atomic mass, atomic radius, volume, and ion radius are 168.93421, 0.242nm and 18.1/cm³/mol, 0.0869nm. Theodore Cleve was the discoverer of Tm. In 1897, he discovered it from "Baitu". In order to commemorate its motherland Scandinavia, the Tm was named metal iron is silver, with excellent physical elasticity and soft texture, which be cut with a knife. The chemical activity of Tm is stable in the air relatively. Because of these special characters, it is suitable for the S-band.

According to the energy level structure of the doped ions in the optical fiber and the wavelength of the pump light, the fiber amplifier can mainly divide into a three-level system, a level system and an up-conversion system. In contrast, the energy level system of Tm belongs to level system. As shown in figure, after ions in the ground state energy level absorb the pump light energy, particles jump to the high energy level E3. The particles on the energy level will rapidly transfer to a metastable state through a non-radiative transition, called the E2 energy level. As the lifetime of E2 energy level is too long, particles at ground level transfer to E2 energy level, so that the number of particles on E2 energy level is continuously accumulated, and finally, realize E2 energy level and lower energy level stable. The number of particles is reversed. When the signal light corresponding to the E1 transition passes through the amplifier, under the action of emission, the particles at the E2 level release the same laser light as the signal light and return to E1. The particles of the energy level then return to the ground state energy level E0 through the radiative transition so that the signal passing through the amplifier is effective.

Just like other kinds of fiber amplifiers, the structure of TDFA is just like different kinds. They are all composed of a pump source, gain medium (i. e. , doped fiber), isolator, wavelength division multiplexer, power control module, and temperature control module. In practical application, according to the different requirements of the system for gain, output power and noise figure, different structural schemes need to be adopted. There are usually three basic structures: forward. As shown in the figure 1, it can be called forward pumping means that the pump light and the signal light pass through the doped fiber in the same direction. Reverse or backward pumping means that the pump light and the signal light pass. In the bidirectional pumping structure, the pump light passes through the doped fiber in both directions.

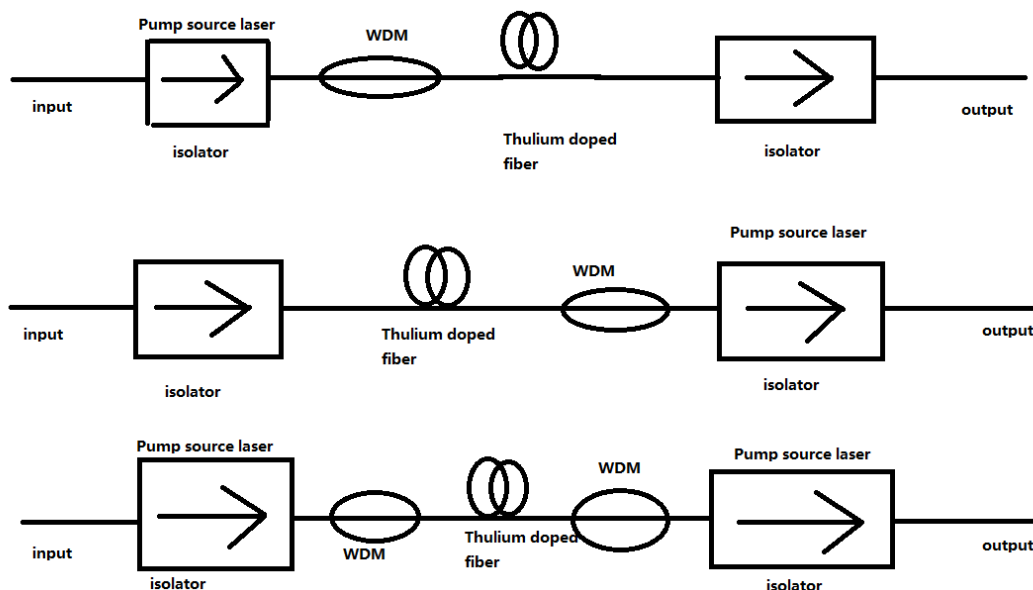

Figure 1. Forward, backward, double sides pumping structure of TDFA

3. Experiment

Tm doped amplifier gain modeling and numerical simulation for 1400 – 1520nm signal. The parameters of this experiment are set to:

Input signal power $1 \times 10^{-6}W$, signal wavelength 1500nm, pump wavelength 980nm, pump power at input end of fiber ($z=0$) 0.1W, ASE power in signal bandwidth power at input end of fiber ($z=0$) 0W, emission cross section at signal wavelength $1 \times 10^{-24}m^2$, absorption cross section at signal wavelength $1 \times 10^{-24}m^2$ absorption cross section at pump wavelength $2 \times 10^{-24}m^2$.

The length of optical fiber has a great influence on signal transmission. Of course, there is an optimal length of optical fiber for signal transmission. This experiment aims to explore the influence of different optical fiber lengths on signal amplification gain and the optimal length of optical fiber when the input signal power and pump power are certain. By solving the rate equation and the transmission equation, a simulation model of the effect of different fiber lengths on signal gain, signal power, pump power, and ASE power is constructed at the same input power, the same signal wavelength, and the same pump wavelength. Finally, the optimal fiber length for 1500nm signals is obtained based on these simulation models.

The code has simulated the change of 1400-1520nm signal gain, signal power, pump power and ASE power at different fiber lengths. A numerical model of the doped amplifier is developed by solving the laser rate and transmission equations.

3.1 Tm doped amplifier gain modeling

Gain simulations for thulium-doped fiber amplifiers are designed to explore the optimal fiber length for maximum signal gain. The curves in the image represent the change in signal gain with the length of the fiber. When the thulium-doped fiber length is greater or less than the optimal length, the number of particles is not completely reversed, and the signal gain does not reach the maximum. The length of the optical fiber is 2.6m, at this time, the number of particles excited by each energy level reaches the maximum value, and the signal gain reaches the maximum value.

Model the incorporation amplifier gain by code, and Figures 2. (a-b) show the incorporation amplifier gain at different fiber lengths. The gain reaches a maximum value of 46 dB at a fiber length of 2.61m. Moreover, when the fiber length is below 2.6m, the amplification gain of the signal is significantly increasing from 0dB to about 46dB. After the signal gain reaches the maximum value of 46db, the signal gain begins to decrease gradually and slowly as the length of the fiber increases. However, the slope of the falling curve is significantly lower than the slope when it rises. Then when

the fiber length is about 7m, due to the excessive length of the optimal fiber, the utilization efficiency of the pump light is significantly reduced, resulting in a more obvious decrease in the gain coefficient and an increase in the slope of the decline. As the length of the fiber increasing, the gain coefficient first undergoes a linear change. Then the gain reaches the maximum, indicating that the gain coefficient reaches saturation due to the gain saturation caused by the pump light. Then the gain coefficient gradually decreases, indicating that when the length of the fiber exceeds the optimal length, the utilization efficiency of the pump light is significantly reduced, which reduces the gain coefficient. In order to maximize the signal gain as much as possible, it set the fiber length to be between 2 and 3 m.

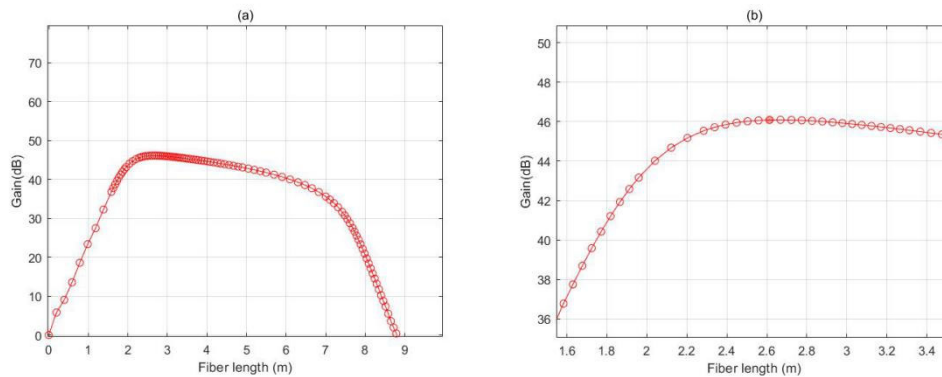

Figure 2(a) Gain of the doped amplifier at different fiber lengths. (b)Gain of the blending amplifier at different fiber lengths (local amplification diagram).

3.2 Modeling of the signal power of the Tm doped amplifier

This curve is a curve that represents the change of signal power with the length of the fiber. It can be observed in the Figure 3. (a-b) that the signal power varies with the fiber length for a certain pump power. When the fiber length is 2.671m, the maximum signal power is 0.04142W. This paper can observe that when the length of the fiber is more than 7.6m below 1.3m, the signal power is 0W. When the fiber length increases to more than 1.3m, the signal power increases significantly until the maximum value is 0.04W, at which point the fiber length is about 2.6m. When the length of the fiber is greater than 2.6m, the signal power begins to decrease gradually, and finally, power drops to 0W.

The principle of fluctuation of the signal output power image is the same as the principle of gain coefficient change, both because the utilization efficiency of pumped light varies with the length of the fiber. As with the change in gain coefficient, when the length of the fiber is within 2.6m, the pump light utilization efficiency does not reach the maximum value, and it is positively correlated with the length of the fiber, so the signal output power is also increasing. At 2.6m, the utilization efficiency reaches the maximum value, which is the optimal fiber length, and the signal output power reaches a maximum of 0.04W. After the length of the optical fiber exceeds 2.6m, the pump light utilization efficiency is weakened, so the signal power is gradually reduced to 0W.

At a certain pump power, when the optimal fiber length is around 2.6m, the amplification conditions are met everywhere, so that the pump power utilization rate is maximized, and the signal power reaches the maximum value. After the optimal fiber length is reached, the signal power gradually decreases as the pump power utilization decreases, then decreases to 0W. Comparing the optimal fiber length when the maximum gain 46dB is generated, it is found that the best fiber length of gain and signal power are about 2.6m. And according to the formula $P_{\text{signal power}} = G \times P_{\text{input power}}$, where $P_{\text{signal power}}$ is signal power, G is gain coefficient, $P_{\text{input power}}$ is signal input power, the correctness of the experiment can be confirmed.

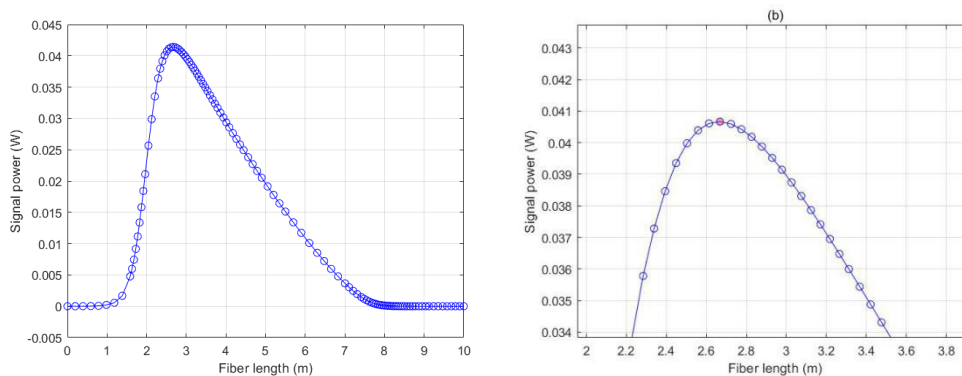

Figure 3. (a) Signal power of the doped amplifier at different fiber lengths. (b) Signal power of the doped amplifier at different fiber lengths. (local amplification diagram)

3.3 The Tm doped amplifier pump power modeling

Pumping is a process that uses light to raise electrons in atoms or molecules from lower levels to higher levels. The threshold pump power can be either input or absorbed for optical pump lasers. For applications, more concern about the input pump power. However, the absorbed pump power is more useful for determining the gain efficiency of the gain medium. Low pump threshold power is obtained only when the cavity loss of the resonator is low, and the gain efficiency is high. High gain efficiency is usually obtained using a small mode field area gain medium with a high-product. The emission bandwidth limits the $\sigma\tau$ product. Thus, the broadband gain medium tends to have a higher laser threshold.

In the image is a curve of pump power changing with the length of the fiber, the overall change is similar to exponential decay. It is obviously to observe in Figure 4. (a-b), the input pump wavelength is 980nm, the pump power at the end of fiber($z=0$) is 0.1W, the pump power gradually decays to 0W along with the length of the optical fiber increasing. The pump power must be higher than the laser threshold. When the length of the fiber exceeds 2.6m until it is close to 3.3m, the pump light gradually decreases to the threshold light intensity, indicating the optimal fiber length must be less than 3.3m when the threshold light intensity is dropped.

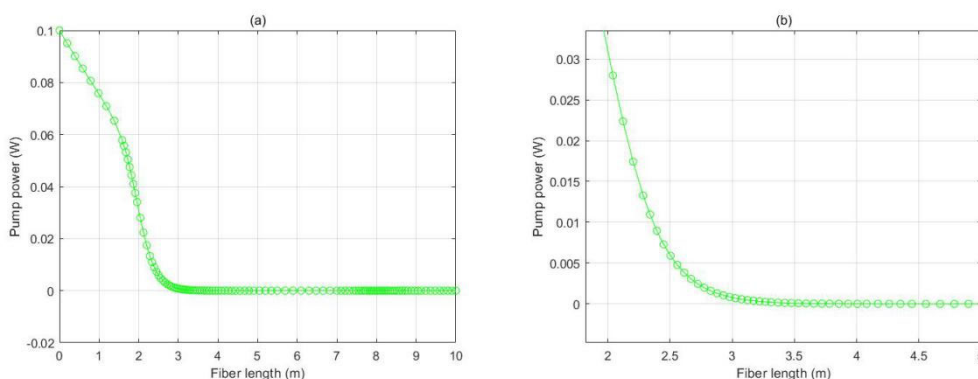

Figure 4. (a) Pump power of the doped amplifier at different optical fiber lengths. (b) Pump power of the doped amplifier at different optical fiber lengths (local amplification diagram).

3.4 ASE power modeling of the Tm doped amplifier

As the activated particle returns to the ground state from the excited state and amplifies the light signal, it also produces random incoherent spontaneous radiation of the excited particle, which is the source of ASE noise. In some fiber amplifiers, no laser light can be generated at other wavelengths, if the gain is sufficient to produce a strong ASE, then at specific frequencies. This problem can be solved by optimizing the laser design, for example by optimizing the fiber length, doping degree, etc. Although the ASE in an optical fiber amplifier is not strong enough to extract a lot of energy from it, it produces a lot of noise for the amplified signal.

As shown in Figure 5. (a-b), the spontaneous amplified radiation reaches the maximum value when the fiber length is about 2.6m. It then gradually decreases to 0W when the fiber length is about 8m.

The number of particles excited under certain conditions is determined, and the more particles used to generate ASE, the fewer particles can be used to provide signal gain. That is to say, the greater the ASE noise, the less power the signal is amplified, the smaller the signal gain. The time coherence of ASE is weak. In the time domain, there is a very fast random fluctuation of the associated electric field, that is, it has a very short coherent time and coherence length. In the frequency domain, this corresponds to a large bandwidth. This bandwidth can be of the same order of magnitude as the gain bandwidth, but it is usually much smaller than the gain bandwidth, especially at high gain. So even when the signal generates maximum gain, the ASE noise reaches its maximum value, but the ASE noise is negligible compared to the signal gain.

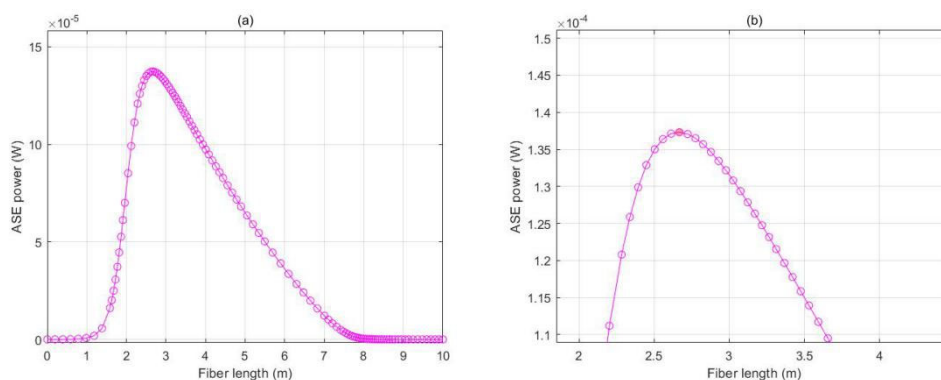

Figure 5. (a) The ASE power of the doped amplifier at different fiber lengths. (b) The ASE power of the doped amplifier at different fiber lengths(local amplification diagram)

4. Conclusion

The output characteristics of gain modulated Thulium-doped fiber oscillator and amplifier are studied by numerical simulation and experiment. The numerical models of the oscillator and the amplifier are constructed based on the laser rate equation and the transmission equation. The output of the laser is simulated by the FDTD method. This chapter analyzes some basic theories and knowledge of doped fiber amplifiers. Rust ion belongs to a four-level system but has a complex energy-level structure. Among them, the wavelength range of them emitted by the stimulated transition of is exactly S band.

Based on the rate equation and the transmission equation, this paper derives the model of the change of signal gain, signal power, pump power, and ASE power with fiber length in TDFA. When the length of the fiber is about 2.6m, the signal gain can be maximized. At this time, the signal power and the pump power also reached the maximum, confirming the experiment's correctness. When the fiber length is about 2.6m, the utilization rate of the pump light intensity reaches the maximum, but at the same time the ASE noise also reaches the maximum value, but comparing the signal gain with the ASE noise, due to the incoherence of the ASE noise, the ASE noise can be ignored, 2.6m is the best fiber length for the 1500nm wavelength signal of the thulium-doped fiber amplifier.

The main research work of this paper is carried out under certain ideal conditions. During the simulation, some parameter was ignored. Therefore, the conclusion is not very accurate. But for studying its basic amplifier, the relationship between output signal gain performance, fiber length, doping concentration, and pump power is sufficient. And the author will do more research to perfect the experiment.

References

- [1] M. A. Noginov, M. Curley, P Venkateswarlu, A. Williams. Excitation Scheme For The Upper Energy Levels In A Tm:Yb:Bay2fg Laser Crystal. Optical Society Of America. 1997. 14(18). 2126-2136

- [2] Allain, J. Y Monerie, M. Poignant, H. Tunable Cw Lasing Around 0.82, 1.48, 1.88, 2.35, *M In Thulium-Doped Fluorozirconate Fiber*. Electronics Letters. 1989. 25(24). 1660-1662
- [3] Dai Shixu, Yang Jianhu, Liu Zhuping, Jiang Zhonghong. Latest Research Progress Of Tdfa. *Optical Fiber And Cable And Its Application Technology* 2000. (3). 12-17
- [4] Komukai, T. Yamamoto, T. Sugawa, Y Miya Ima. 1.47. *M Band Tm³⁺ Doped Fluoride Fibre Amplifier Using A 1.064. μ m Upconversion Pumping Schemet*. Electronic S Letters. 1993. 29(1). 110-112
- [5] S. Aozasa, T. Sakamoto, T. Kanamori, K. Hoshino, K. Kobayashi, M. Shimizu. *Tm-Doped Fiber Amplifiers For 1470-Nm-Band Wdm Signals*. Ieee Photonics Technology Letters. 2000. 12(10). 1331-1333
- [6] Du Zo, Li Da, Li Hong-Wei, Ruan Shuang-Chen. *A Bi-Directionally Pumped S-Band. Thulium-Doped Silica Fiber Amplifier Using Up-Conversion Pumping At 1064nm*. Acta Photonica Sinica. 2007. 36(17). 966-968
- [7] V T. Chen, Lon A. Wang. *Laser-To-Fiber Coupling Scheme By Utilizing A Lensed Fiber Integrated With A Long-Period Fiber Grating*. Ieee Photonics Technology Letters. 2000. 12(5). 501-503
- [8] Xue Chunrong. *Characteristics Of Fused Taper Optical Fibers-Laser And Infrared* 2006. 36(9). 886-888
- [9] Ma Yan, Xie Fuzeng. *Design Of A Tapered Lens For Semiconductor Laser To Single-Mode Fiber Coupling*. Chinese Journal Of Semiconductors. 2004. 25(11),1356-1359
- [10] Li Aiyun, Wang Xiaoying, *Study On Optical Field Characteristics Of Fiber Coupled Ld Output*. Acta Photonica Sinica. 2007. 36(9). 1664-1667
- [11] Abdul Azeez R. Al-Rushed, Bahaa E. A. Saleh. *Decentered Gaussian Beams*. Applied Optics. 1995. 34. 01. 6819-6825
- [12] Zhang Jun, Feng Ying, Chen Shuang. *Design And Analysis Of High-Power Laser Fiber Coupling System*. Optics And Photoelectric Technology. 2007. 5(1). 47-52
- [13] Zheng Yong. *Laser Semiclassical Theory Of Three-Level System*. Journal Of Beijing University Of Technology 1994. 20. 120-123
- [14] Liu Lin. *Radium Doped Fiber Amplifier And Its Applications*. Thesis 1. Southeast University. Southeast University. 2003. 25-32
- [15] Liao Meisong, Fang Yongzheng, Sun Hongtao, Hu Lili, Zhang Junjie, *Structure, Thermal Properties And Spectral Properties Of Iron Doped Fluorophosphate Glass*. Acta Optica Sinica. 2006. 26(5). 713-719
- [16] Won Jae Lee, Bumki Min, Jaehyoung Park, Namkyoo Park. *Study On The Pumping Wavelength Dependency Of S-Band Fluoride Based Thulium-Doped Fiber Amplifiers*. Ofc. Anaheim. 2001. American. 2001.
- [17] Liu Bin. *Research On Iron Doped Fiber Amplifier*. Thesis 1. Beijing Jiaotong University. Beijing Jiaotong University. 2006. 3-40
- [18] Mira Naftaly, Shaoxiong Shen, Animesh Jha. *Tm³⁺-Doped Tellurite Glass For A Broadband Amplifier At 1.47. μ m*. Applied Optics. 2000. 39(27). 4979-4984
- [19] Wang Xunsi, Nie Qiuhua, Xu Tiefeng, Shen Xiang, Dai Shixun, Gai Na. *Tm³⁺-Doped Tellurite Glass With Yb³⁺ Energy Sensitized For Broadband Amplifier At 1400-1700nm Bands*. Journal Of Rare Earths. 2008. 2b(Fi. 907-911
- [20] A. Cucinotta, F Poli, S. Selleri. *Gain Characteristics Of Thulium-Doped Tellurite Fiber Amplifiers By Dual-Wavelength (800nm+1064nm) Pumping*. Ofc. Martin Fermann. 2003. America. 2003. 11-12
- [21] Deng Yuanlong, Yao Jianshuan, Ruan Shuangshen, Sun Xiuquan. *High Power Laser Fiber Lens Coupling System Design*. Photoelectric Technology Application. 2007. 20 (3). 7-10
- [22] He Shenjuan, Chen Xiaobo, N. Sawanobori, Sun Yinguan, Chen Ying, Meng Chao. *Spectral properties of Tm³⁺-in oxyfluoride glass ceramics*. Spectroscopy and spectral analysis. 2001. 21 (2). 147-150