

Design and Risk Analysis of an Escalator Safety Step

Zhuo Chen ^a, Shuai Wan ^{b,*}, Zhonggeng Chen ^c, Feng Yang ^d

Chongqing Special Equipment Inspection and Research Institute Chongqing, China

^a Chenzhuo2069@163.com, ^b 2644686842@qq.com, ^c dzcz523@sina.com, ^d 342700934@qq.com

Abstract. In view of the prominent potential safety hazards and frequent accidents of escalator step gap, this paper makes an in-depth analysis of escalator movement gap from the perspective of risk prevention and control, and puts forward a safe step structure, which can effectively isolate passengers from movement gap, greatly reduce the safety risk of movement clearance, avoid involvement in accidents and improve the overall safety performance of escalator. It is conducive to extensive promotion and application.

Keywords: risk analysis, safety step, step gap, involvement accidents, Escalator

1. Introduction

Escalators can be seen everywhere in subway stations, railway stations, shopping malls, airports and buildings, and have become an indispensable part of urban people's travel. However, the escalator clamping accidents occur frequently, which are often seen when the hands or feet of the personnel are clamped into the gaps on both sides of the step tread during the movement of the escalator, and are easy to cause serious consequences [1].

On August 24, 2012, at Wanda Square in Shaoxing, a little boy's left foot was caught in the gap between the step tread and skirting of the escalator. On May 8, 2013, a one-and-a-half-year-old girl in Zhanjiang was caught and her left foot was broken by the escalator when she took the elevator downstairs. On October 24, 2015, in Bao'an District, Shenzhen, a boy broke his toe bone by an escalator.

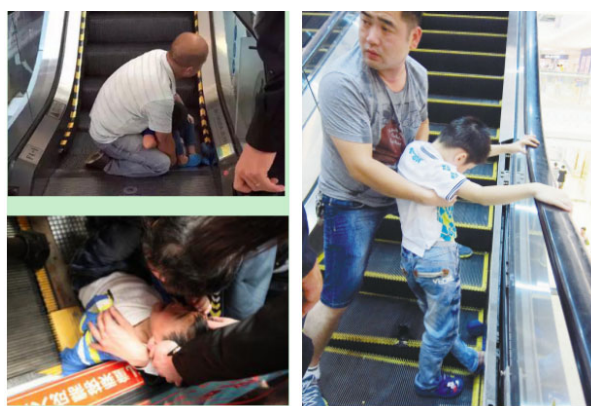

Fig. 1. Accidents of children's limbs stuck in escalators occur frequently

The above accidents are shocking, as shown in Figure 1. They are all caught in the gap on both sides of the step tread during the movement of the escalator, resulting in shear injury [2]. There is also a common and important incentive for children to wear soft shoes. The safety design of the escalator includes the anti pinch device installed on the skirting, and the design of reducing the friction coefficient is adopted at the position close to the gap of the step, which reduces the safety risk to a certain extent.

However, the continuous and frequent accidents show that the safety risk of escalators needs to be further reduced [3].

2. Other similar solutions and problems

In addition to the anti pinch safety device of escalator steps currently used, Jiangnan Jiajie Elevator Co., Ltd. has proposed the invention patent "an apron protection device on escalator or moving sidewalk" (No.201510075540.0)[4], as shown in Figure 2. The patent proposes to install a microswitch behind the apron. When foreign matters enter the gap between the apron and the step or pedal, the apron bulges outward and deforms to trigger the microswitch to stop the operation of the escalator or sidewalk.

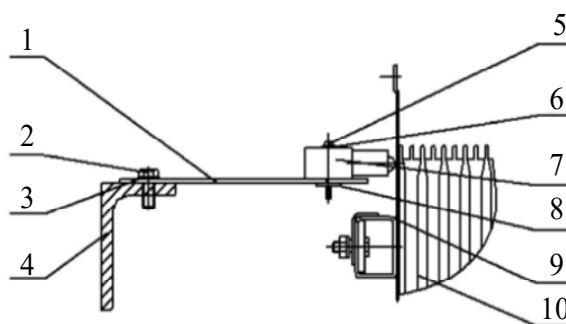

- 1 switch support plate; 2 hexagon head bolts; 3 lock washer;
4 angle steel; 5 cross recessed pan head screws; 6 flat washers;
7 micro safety switch; 8 plate; 9 apron board; 10 rungs or treads.

Fig. 2. Diagrammatic drawing of the apron protection device

The feasibility of this method is low. Firstly, the apron has rigid requirements, which is contrary to the force applied to the microswitch; Secondly, the premise of the safety switch action of this method is that the gap is expanded, which means that the safety device may act after being clamped, which basically does not play a good protective role, with huge investment and unsatisfactory effect.

Adding filler in the gap of the step is also a method, but the filler is easy to wear, troublesome to replace and expensive, so it should not be practical.

Kone Elevator Co., Ltd. proposed a relatively novel escalator and its skirt and steps (Patent No.201210407806.3)[5], as shown in Figure 3. The escalator apron and the step can be embedded with each other in motion, and the contact surfaces of each other are provided with concave convex grooves along the moving direction, just as the side of the step walks on the apron track. The gap is basically eliminated to a very low level.

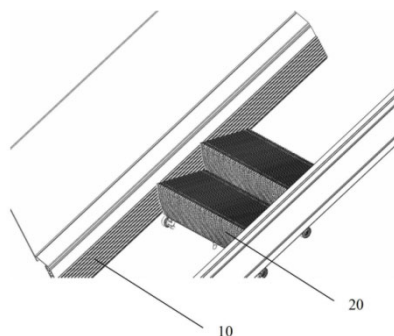

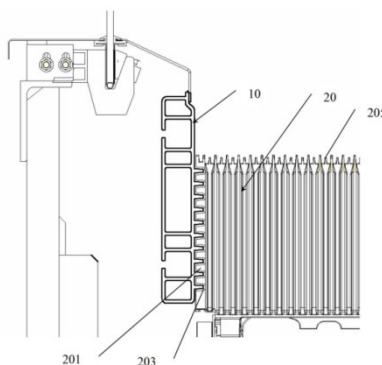

10 skirting; 20 step; 201 Rib; 203 groove; 205 step tread.

Fig. 3. Diagrammatic drawing of the apron board and steps in the shape of the card slot

However, because the apron is only available at the upper part of the escalator, there is no apron inside the escalator. If you want to maintain the normal circular movement of the steps, you need to add the apron of the structure inside the escalator. In this way, the escalator structure is greatly changed, and the manufacturing and installation process requirements of the changed steps and skirt structural parts are high and the cost is increased, which is very unfavorable to promotion and application.

3. Risk analysis of escalator movement gap

The escalator has an open running space, which makes it difficult to meet the basic requirements of intrinsic safety at the beginning of design, and the equipment has unavoidable safety risks [6]. The safety risk caused by the gap between moving steps and stationary skirting is particularly prominent[7].

First, the distance between the gap and passengers is relatively close, especially children are easier to access or even contact the edge of the step. Second, the gap is always accompanied by passengers in the whole process of taking the ladder. Third, there are no other safety measures between the gap and passengers except the safety brush and yellow warning line, and the safety of passengers is not fully guaranteed [8]. Fourth, the soft shoes worn by passengers are more likely to be involved when approaching the gap. Fifth, once the passenger's limbs are involved in the gap, cutting injury will occur, and the consequences are generally serious. Sixth, when an accident occurs, the escalator can be effectively stopped only when the personnel press the emergency stop button, and the injury risk is difficult to control in time.

4. Basic design scheme of safety steps

4.1 Overall Design

According to the above cases, methods and risk analysis, aiming at the safety risk of the movement gap, this paper proposes a safety step and its support plate, which can effectively isolate the passengers from the movement gap without changing the existing escalator step structure, greatly reduce the safety risk of the movement gap and avoid the passengers' limbs from being caught in the gap between the step and the apron [9].

The main structures of safety steps shown in the figure 4 include step, spacer plate, support plate and buffer baffle (shown in the figure 5) .

A spacer plate is set at both ends of the step tread. The support plate at the entrance and exit of the escalator is fixed with a U-shaped structure to ensure that the step and its diaphragm can smoothly pass through the support plate and enter and exit the escalator without obstacles for circular movement. The diaphragm is divided into integral type and split type; The integrated diaphragm and step tread are an integral structure; As an independent component, the split diaphragm is provided with a clamping groove or screw hole at the bottom, the corresponding positions at both ends of the step tread are provided with corresponding clamping grooves or screw holes, and the diaphragm can be fixed at both

ends of the step tread; The tread position of the support plate remains unchanged, and the positions at both ends are raised to an appropriate height to make a gap between the vertical surface and the skirt. The height of the gap is slightly greater than the height of the baffle, and the width is also slightly greater than the width between the baffle and the skirt, so that the step baffle can pass through without being affected. Both ends of the support plate extend into the interior of the escalator skirt and are fixed.

The spacer plates are designed at both ends of the step tread, perpendicular to the tread without increasing the total width of the step, and are consistent with both sides of the step tread.

As the diaphragm protrudes from the tread, the support plate at the inlet and outlet of the step shall be designed into a U-shape to leave clearance space for the diaphragm. The comb width is consistent with the width of the support plate.

The buffer baffle is installed on the side plate of the support plate to block the movement gap of the diaphragm.

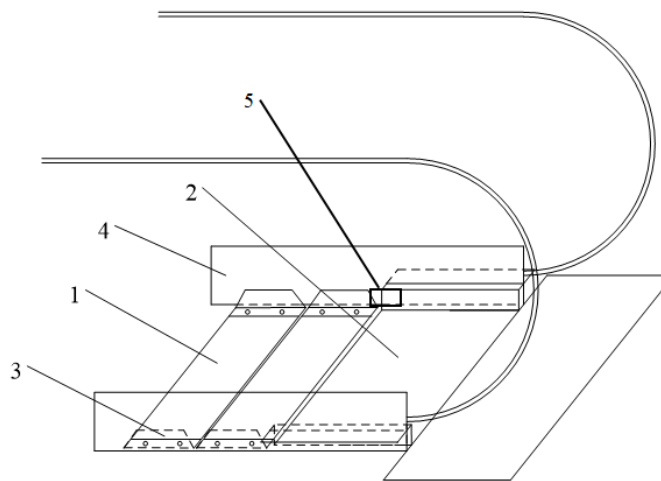

1 step; 2 support plate; 3 spacer plate; 4skirting; 5 buffer baffle.

Fig. 4. Diagrammatic drawing of safety step

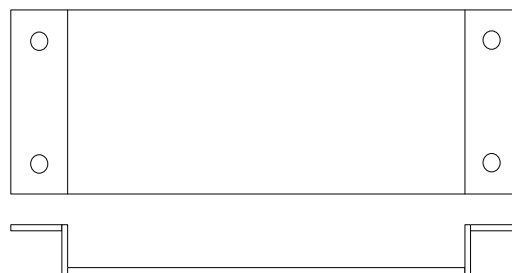

Fig. 5. Diagrammatic drawing of buffer baffle

4.2 Design Features of the Spacer Plate

The shape, height, width and thickness of the spacer plate can be designed according to the structural characteristics of different escalators.

First, the strength of the spacer plate shall meet the requirements that plastic deformation is not easy to occur under the conditions of passengers stepping on and objects impacting. Second, the position of the spacer plate will not shift under the conditions of passenger stepping, object impact, step vibration and so on. Third, the spacer plate shall avoid friction and collision with the bottom of the escalator.

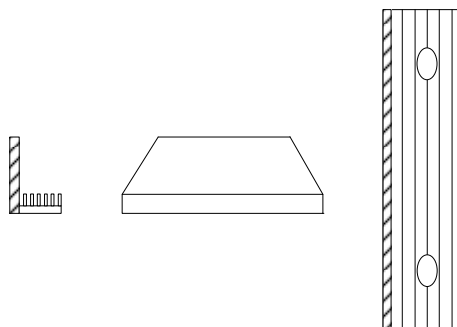

Fig. 6. Diagrammatic drawing of spacer plate

In this principle, the height of the spacer plate shall be within 20 mm ~ 30 mm, and the thickness shall not be less than 2mm, as shown in Figure 6. The spacer plate shall be installed at the edge of the step tread and painted with warning color.

The spacer plate blocks the movement gap at the edge of the step tread, effectively blocks the position of the passenger's feet from the movement gap, avoids the danger of further approaching, touching or even clamping in, reduces the probability of injury to passengers, reduces the safety risk of the movement gap to a relatively low level, effectively protects the safety of passengers and improves the overall safety of the escalator. On the other hand, the spacer plate has the advantages of simple structure, low cost, flexible means of implementation, small changes to the escalator structure, and easy to promote and implement.

4.3 Design Features of the Buffer Baffle

When the moving step passes through the comb plate, the movement gap between the spacer plate and the support plate also has safety risks, which can be reduced by adding a buffer baffle.

The buffer baffle is made of rubber material, fixed on the side of the support plate and covers the movement gap.

When the foreign matter is brought into the gap by the spacer plate, the colloidal baffle will be squeezed into the movement gap first. When it is slightly squeezed, the foreign matter will pop up or retract immediately when it is blocked. If the extrusion is serious, the flexible buffer block squeezed more strongly will drive the support plate to move, which will immediately cause the action of the safety protection device of the support plate and stop the elevator immediately. At this time, it will be handled by professional personnel to avoid the possibility of further injury.

4.4 Overall safety risk analysis

The safety step is an active safety design. Its own structural characteristics ensure that passengers have a more effective barrier between the whole process of taking the ladder and the risk gap, making it difficult for passengers' limbs to get involved in the step gap.

The gap between the spacer plate and skirting is above the step gap. Even in case of involvement danger, the spacer plate gap can give early warning and increase the reaction time of passengers to avoid further injury [10].

5. Conclusion

At present, there are some problems in the step gap of escalator, such as long process, weak safety measures, serious injury and so on, which have great safety risks. The safety step proposed in this paper can effectively reduce the safety risk of step gap, help to avoid the occurrence of involvement accidents, help to improve the overall safety performance of escalator, and help to widely carry out popularization and application.

Acknowledgments

The authors would like to express their sincere thanks to the anonymous reviewers for their invaluable suggestions and comments to improve this paper. This work was financially supported by Chongqing Technology Innovation and Application Development Special Project(No.cstc2019jscx-msxmX0065) of Chongqing Science and Technology Bureau.

References

- [1] Y. Hu, P. Wen, "Analysis of an escalator trapping accident," *China Elevator*, vol. 30, no. 12, pp. 55+57, 2019.
- [2] J. Wu, "The setting of escalator safety devices from the perspective of escalator accidents," *Hoisting and Transporting Machinery*, no.5, pp. 91-92+100, 2012.
- [3] A. Ma, "Analysis and Countermeasures of Frequent Escalator Accidents," *Science and Technology Information*, no. 25, pp. 258-259, 2013.
- [4] Jiangnan Jiajie Elevator Co., Ltd.. An apron protection device on an escalator or moving walk[P]. China: 201510075540.0, 2015-6-3.
- [5] Kone Elevator Co., Ltd.. Escalator and its skirt and steps[P]. China: 201210407806.3, 2014-5-7.
- [6] W. Sun, L. Yan, "Technical Analysis of Escalator Safety Accidents," *China Elevator*, vol. 30, no. 1, pp. 45-47, 2019.
- [7] C. Zhu, Z. Hong, "Safety problems on both sides of escalator steps ," *Hoisting and Transporting Machinery*, vol. 2000, no.6 , pp. 28-30.
- [8] X. Wang, "Research on Escalator Accident Mode and Emergency Plan," *China Elevator*, vol. 30, no. 6, pp. 52-53, 2019.
- [9] J. Wang, "Design and research of a safety protection device to reduce the injury degree of escalator trapping accidents," *China Special Equipment Safety*, vol. 34, no. 2, pp. 20-22, 2018.
- [10] H. Wu, "Research on Risk Assessment of Escalator Safety Accidents by LEC Method," *China Elevator*, vol. 29, no. 22, pp. 65-66+72, 2018.