

Design and Implementation of a Chip Removal Device for Metal Fittings with Adjustable Cleaning Range

Qingqing Zhang, Zhiqiang Wan

Anhui Technical College of Mechanical and Electrical Engineering, Wuhu, Anhui, China

Abstract. The design and implementation of a chip removal device for metal fittings with adjustable cleaning range. The device includes a base, a first motor, a handle, a collecting box, a second motor and a fan. The left and right sides of the upper part of the base are separately welded and connected with the left and right columns, and the left and right sides of the placing plate are provided with a limited position plate. The limit plate and the left column and the right column are respectively sliding connection, and the spacing between the two splints on the placement plate can be adjusted, so that the placement plate can be moved back and forth without affecting the fixation of metal accessories, and then the opening operation can be carried out for different positions of accessories, which improves the flexibility of the device in use.

Keywords: Metal Accessories; Opening; Chip Removal Device; Cleaning.

1. Introduction

Metal accessories refer to some parts of mechanical equipment, which play an important role in the use of mechanical equipment. Some accessories need to be perforated during production and processing to adapt to the use of mechanical equipment. Moreover, the shapes of accessories are different, including rectangular shape and circular shape. When the accessories are perforated, waste chips will be generated, so chip removal device will be used [3].

However, the existing chip removal device still has some deficiencies in the use process, such as:

1. The waste chips during the opening of accessories are easy to remain in the corner and are not easy to clean. The chip removal device is inconvenient to adjust the cleaning range, resulting in insufficient cleaning and affecting the cleanliness of the chip removal device [1] [2].

2. When the accessories are opened, the waste chips will splash, which not only affects the surrounding environment, but also is not convenient for the later staff to clean up, thus reducing the practicability of the chip removal device. Based on this, a chip removal device for opening metal parts with adjustable cleaning range is proposed to solve the above problems [8].

2. Technical Design Scheme

The utility model relates to a chip removal device for opening metal accessories with adjustable cleaning range, as shown in Fig. 1, which comprises a base, a first motor, a handle, a collection box, a second motor and a fan. The left and right sides above the base are respectively welded and connected with a left column and a right column, the inner wall of the left column is bolted with a hydraulic cylinder, the output end of the hydraulic cylinder is connected with the cross plate, and the bolt of the first motor is installed directly above the cross plate, The output end of the first motor is connected with the drill pipe, and the left and right sides of the drill pipe are connected with the first rotating shaft through the first transmission belt. The bottom end of the first rotating shaft is installed with a suction fan blade, and the outside of the suction fan blade is provided with a baffle. The rear side of the baffle is installed with a collection cylinder, and the inside of the collection cylinder is connected with a filter screen. A placement plate is arranged below the drill pipe, and the inside of the placement plate is provided with a screw rod, and the screw rod is connected with the connecting plate, The upper part of the connecting plate is connected with a splint, the inner wall of the splint is installed with cushion blocks, the left and right sides of the placement plate are installed with limit plates, the handle is welded and connected to the right end of the screw rod, and a fixing piece is arranged above the handle, a connecting hole is arranged on the handle and the fixing piece, and an

inserting rod is connected inside the connecting hole, the front and rear sides of the connecting plate are provided with clamping blocks, and the clamping blocks are connected with the placement plate through grooves, The groove is arranged on the inner wall of the placement plate, the collection box is arranged below the placement plate, the collection box is welded on the inner sides of the left column and the right column, the second motor bolt is connected to the outer wall of the right column, the output end of the second motor is connected with the second rotating shaft, the outer wall of the second rotating shaft is welded and connected with the second conical gear, and the second conical gear is meshed with the second conical gear, The interior of the second bevel gear is penetrated with a first rotating rod, and the first rotating rod is connected with the second rotating rod through the second transmission belt. The second rotating rod is provided with an air outlet, and the second rotating rod is connected with the collection box through the support rod, and the interior of the support rod is provided with a connecting pipe. The fan is installed on the right side of the base, the bottom of the fan is provided with an air inlet pipe, and the top of the fan is connected with the connecting pipe.

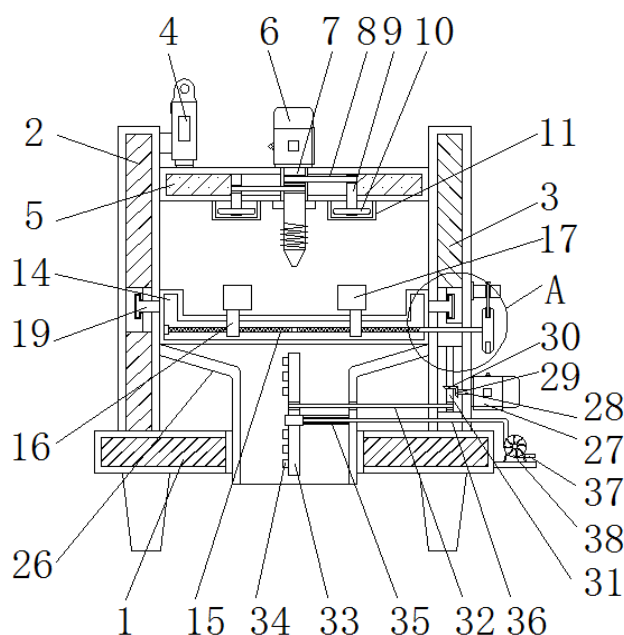

1. Base; 2. Left column; 3. Right column; 4. Hydraulic cylinder; 5. Transverse plate; 6. The first motor; 7. Drill pipe; 8. The first drive belt; 9. The first rotating shaft; 10. Suction fan blade; 11. Baffle; 12. Collecting cylinder; 13. Filter screen; 14. Place the plate; 15. Screw rod; 16. Connecting plate; 17. Splint; 18. Cushion block; 19. Limit plate; 20. Handle; 21. Fixings; 22. Connecting hole; 23. Inserting rod; 24. Clamping block; 25. Groove; 26. Collection box; 27. Second motor; 28. Second rotating shaft; 29. First bevel gear; 30. Second bevel gear; 31. The first rotating rod; 32. Second drive belt; 33. Second rotating rod; 34. Air outlet; 35. Support rod; 36. Connecting pipe; 37. Fan; 38. Air inlet pipe.

Fig 1. Schematic diagram of overall main section structure

3. Example Given to Illustrate

The utility model relates to a chip removal device for opening metal accessories that can adjust the cleaning range, as shown in Fig. 1-fig. 7, which comprises a base 1, a left column 2, a right column 3, a hydraulic cylinder 4, a transverse plate 5, a first motor 6, a drill pipe 7, a first transmission belt 8, a first rotating shaft 9, a suction fan blade 10, a baffle 11, a collecting cylinder 12, a filter screen 13, a placement plate 14, a screw rod 15, a connecting plate 16, a splint 17, a cushion block 18, a limit plate 19, a handle 20, a fastener 21, a connecting hole 22, an inserting rod 23 The clamp block 24, the groove 25, the collection box 26, the second motor 27, the second rotating shaft 28, the first

bevel gear 29, the second bevel gear 30, the first rotating rod 31, the second transmission belt 32, the second rotating rod 33, the air outlet 34, the support rod 35, the connecting pipe 36, the fan 37 and the air inlet pipe 38 are welded and connected with the left column 2 and the right column 3 respectively on the upper left and right sides of the base 1, and the inner wall of the left column 2 is bolted with the hydraulic cylinder 4, The output end of the hydraulic cylinder 4 is connected with the cross plate 5, the bolt of the first motor 6 is installed directly above the cross plate 5, and the output end of the first motor 6 is connected with the drill pipe 7, and the left and right sides of the drill pipe 7 are connected with the first rotating shaft 9 through the first transmission belt 8. The bottom end of the first rotating shaft 9 is equipped with a suction fan blade 10, the outside of the suction fan blade 10 is equipped with a baffle 11, and the rear side of the baffle 11 is equipped with a collection drum 12, The inside of the collecting barrel 12 is connected with a filter screen 13, the lower part of the drill pipe 7 is provided with a placing plate 14, the inner part of the placing plate 14 is provided with a screw rod 15, and the screw rod 15 is connected with the connecting plate 16. The upper part of the connecting plate 16 is connected with a splint 17, the inner wall of the splint 17 is installed with a cushion block 18, the left and right sides of the placing plate 14 are installed with a limit plate 19, the handle 20 is welded to the right end of the screw rod 15, and the upper part of the handle 20 is provided with a fixing piece 21, The handle 20 and the fixing part 21 are provided with a connecting hole 22, the interior of the connecting hole 22 is connected with an inserting rod 23, the front and rear sides of the connecting plate 16 are provided with a clamping block 24, and the clamping block 24 is connected with the placement plate 14 through a groove 25, and the groove 25 is opened on the inner wall of the placement plate 14, the collection box 26 is arranged below the placement plate 14, the collection box 26 is welded to the inner sides of the left column 2 and the right column 3, and the second motor 27 is bolted to the outer wall of the right column 3, The output end of the second motor 27 is connected with the second rotating shaft 28, and the outer wall of the second rotating shaft 28 is welded and connected with the first conical gear 29, the first conical gear 29 is meshed and connected with the second conical gear 30, the interior of the second conical gear 30 is penetrated with the first rotating rod 31, and the first rotating rod 31 is connected with the second rotating rod 33 through the second transmission belt 32, and the second rotating rod 33 is provided with an air outlet 34, The second rotating rod 33 is connected with the collection box 26 through the support rod 35, and the interior of the support rod 35 is provided with a connecting pipe 36. The fan 37 is installed on the right side of the base 1, the bottom of the fan 37 is provided with an air inlet pipe 38, and the top of the fan 37 is connected with the connecting pipe 36.

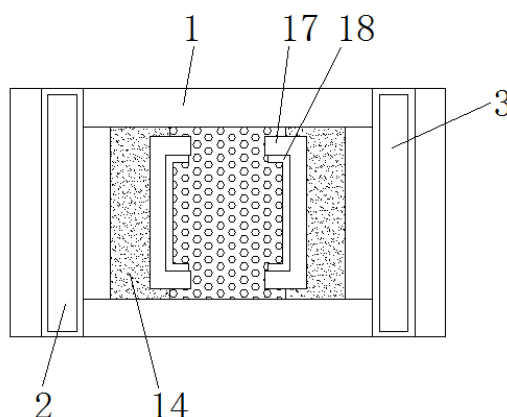

Fig 2. Top view structure diagram of splint and cushion block connection

Two suction fan blades 10 are arranged, and the two suction fan blades 10 are symmetrically distributed about the longitudinal center line of the drill pipe 7. In this way, when the drill pipe 7 opens the hole for the metal fittings, the two suction fan blades 10 can be driven to rotate together, so that the debris during the opening can be adsorbed, which can not only effectively reduce the impact of debris on the surrounding environment, but also facilitate the later cleaning work of the staff;

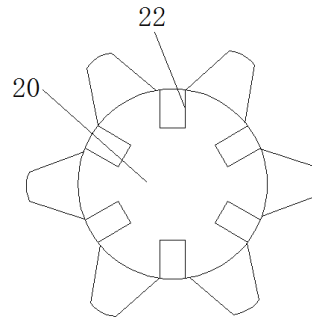

Fig 3. Right view structural diagram of handle and connecting hole connection

The baffle plate 11 is connected with the cross plate 5 and the collecting cylinder 12 by bolts, and the bottom of the baffle plate 11 is hollow, and the collecting cylinder 12 and the filter screen 13 are connected by bolts. At the same time, the aperture of the filter screen 13 is 0.1-0.5mm, which ensures the firmness of the connection between the filter screen 13 and the collecting cylinder 12. Moreover, when the collecting cylinder 12 normally discharges the air flow, the debris can be intercepted through the filter screen 13 to ensure the same cleaning of the debris in the later stage;

The connection mode between the connecting plate 16 and the screw rod 15 is threaded connection, and the connecting plate 16 and the clamping block 24 are in an integrated structure, and the clamping block 24 forms a sliding structure with the placement plate 14 through the groove 25. At the same time, the clamping block 24 is in a "t" shape, the middle of the placement plate 14 is in a multi hole shape, and the threads at the left and right ends of the screw rod 15 rotate in the opposite direction. When the screw rod 15 rotates, it can drive the connecting plate 16 to move, so as to facilitate the adjustment of the spacing of the splint 17, It can be used for fixing metal fittings with different widths, and the connecting plate 16 can move more smoothly under the action of the clamping block 24;

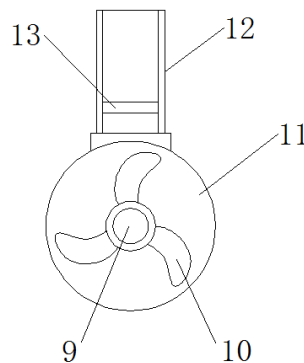

Fig 4. Top view structure diagram of baffle and collecting cylinder connection

The connection mode of the splint 17 and the cushion block 18 is bonding, and the cushion block 18 is made of rubber, and the splint 17 and the connecting plate 16 are welded. In this way, when fixing the metal parts, the metal parts can be protected by the cushion block 18 to effectively reduce the wear of the metal parts;

The limit plate 19 and the placement plate 14 are an integrated structure, and the limit plate 19 is slidably connected with the left column 2 and the right column 3 respectively, and the structure of the limit plate 19 is the same as that of the clamping block 24, so that when the metal parts are perforated, the placement plate 14 can be moved back and forth, so as to facilitate the movement of the metal parts together, and the opening operation can be carried out at different positions;

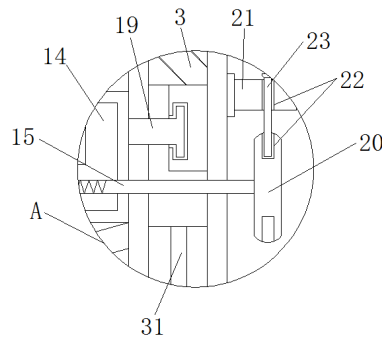

Fig 5. Enlarged structural diagram at a in Fig. 1

The connecting holes 22 are equiangularly distributed on the handle 20, and the connecting way between the connecting holes 22 on the handle 20 and the fixing part 21 and the inserting rod 23 is threaded connection, and the connecting way between the fixing part 21 and the right column 3 is sliding connection, which is convenient for limiting and fixing the handle 20, so as to effectively prevent the self-rotation of the handle 20 and further ensure the normal fixation of metal accessories;

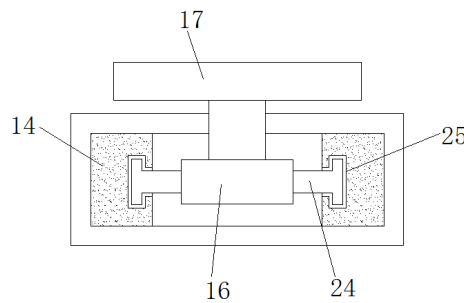

Fig 6. Right sectional structure diagram of connecting plate and clamp block

The air outlets 34 are equally spaced on the second rotating rod 33, and the second rotating rod 33 and the connecting pipe 36 are welded, and the connecting pipe 36, the second rotating rod 33 and the air outlet 34 are connected with each other, which can make the air outlet 34 rotate with the second rotating rod 33, so as to adjust the angle of the air outlet 34, make the interior of the collection box 26 cleaned more fully and ensure the cleanliness of the interior of the collection box 26;

The connection mode between the support rod 35 and the second rotating rod 33 is bearing connection, and the support rod 35 and the collection box 26 are welded, and the interior of the support rod 35 is hollow, which can support and fix the second rotating rod 33 to ensure the stability of the second rotating rod 33 in use.

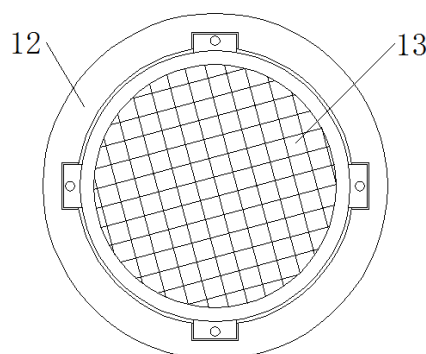

Fig 7. Schematic diagram of rear-view structure of collecting drum and filter screen

4. Working Principle

When using the chip removal device for opening metal parts that can adjust the cleaning range, as shown in Fig. 1-2, first place the device in the corresponding position, then place the metal parts that need to be opened in the middle of the placement plate 14, and then start adjusting the positions of the two clamping plates 17 to fix the metal parts. At this time, as shown in Fig. 3 and Fig. 5, the staff first rotates the inserting rod 23 from the connecting hole 22 on the handle 20 and the fixing part 21, Then turn the handle 20 clockwise to make the handle 20 drive the screw rod 15 to rotate clockwise. Because the threads at the left and right ends of the screw rod 15 rotate in the opposite direction, and the screw rod 15 and the connecting plates 16 on the left and right sides are threaded connection, when the screw rod 15 rotates clockwise, it can drive the connecting plate 16 and the splint 17 to move towards each other, so that the two splints 17 will gradually approach until the two splints 17 are close to the metal fittings, Because the rubber cushion block 18 is bonded on the inner wall of the splint 17, the metal parts can be protected and the wear of the metal parts can be effectively reduced, so as to ensure the service efficiency of the later metal parts [5];

When the metal fittings are fixed, rotate the inserting rod 23 into the connecting hole 22 to fix the handle 20, and then start the hydraulic cylinder 4, which will push the cross plate 5 down. At the same time, start the first motor 6, which will drive the drill pipe 7 to rotate and lower the drill pipe 7 while rotating, so that the metal fittings can be perforated. Since the left and right sides of the drill pipe 7 are connected with the first rotating shaft 9 through the first drive belt 8, In addition, the bottom of the first rotating shaft 9 is equipped with suction fan blades 10, so the two suction fan blades 10 can be rotated while drilling the drill pipe 7 to adsorb and collect the splashed waste during drilling. Since a hollow baffle plate 11 is arranged on the outside of the suction fan blades 10, the waste can be adsorbed to the inside of the collection barrel 12 behind the baffle plate 11, as shown in Figures 4 and 7. Because a filter screen 13 is installed inside the collection barrel 12 and the aperture of the filter screen 13 is 0.1-0.5mm, In this way, when the air flow flows outward, the waste debris can be intercepted, so as to facilitate the unified treatment of waste debris in the later stage. Since the placement plate 14 forms a sliding structure with the left column 2 and the right column 3 through the limit plate 19, the staff can push the placement plate 14 to move back and forth during the opening of metal parts, so that the metal parts can be opened at different positions to ensure the normal opening of metal parts [6];

During the opening of metal accessories, some debris will fall into the collection box 26 from the hole on the placement plate 14. Therefore, when the device works for a long time, debris and dust will accumulate in the collection box 26, and the collection box 26 needs to be cleaned. When it needs to be cleaned, the worker can start the second motor 27 to make the second motor 27 drive the second rotating shaft 28 and the first bevel gear 29 to rotate together, Thus, the first bevel gear 29 drives the second bevel gear 30 and the first rotating rod 31 to rotate together. Because the first rotating rod 31 is connected with the second rotating rod 33 through the second transmission belt 32, it can drive the second rotating rod 33 to rotate together, so that the air outlet 34 on the second rotating rod 33 can rotate together. At this time, the staff can start the fan 37, the fan 37 will absorb air through the air inlet pipe 38, and then transport the air from the connecting pipe 36 to the second rotating rod 33, Finally, it is discharged outward from the air outlet 34, and the second rotating rod 33 and the support rod 35 are connected by bearings, so the stability between the second rotating rod 33 can be ensured. With the continuous rotation of the second rotating rod 33 and the air outlet 34, the interior of the collection box 26 can be cleaned, and the cleaning range can be changed to make the interior of the collection box 26 cleaned more fully, which brings convenience to the staff and improves the practicability of the device, so as to complete a series of work [4] [7].

5. Conclusion

Compared with the prior art, the innovation of a chip removal device for opening metal accessories that can adjust the cleaning range is as follows:

(1) The second rotating rod is provided with an air outlet, and the second rotating rod, the air outlet and the connecting pipe are connected with each other, and the connecting pipe is connected with the fan. At the same time, the second rotating rod is connected with the bearing of the support rod, so that when the fan is working, the air can be transported to the connecting pipe, then transported to the second rotating rod through the connecting pipe, and finally the air is discharged from the air outlet, so that the air outlet can rotate while discharging air, The residual debris in the collection box can be better cleaned, and the cleaning range is adjusted, so as to make the internal cleaning of the collection box more sufficient and ensure the cleanliness of the collection box.

(2) The left and right sides of the drill pipe are connected with the first rotating shaft through the first transmission belt, and the bottom of the first rotating shaft is equipped with suction fan blades, and the outer side of the suction fan blades is equipped with baffles. At the same time, the lower surface of the baffles is hollow, while the rear side of the baffles is equipped with a collection cylinder, and the interior of the collection cylinder is equipped with a filter screen, so that when the drill pipe opens holes for metal fittings, the suction fan blades on the left and right sides can be driven to rotate together, the debris generated during opening is adsorbed and collected. With the adsorption and circulation of the air flow, the air flow will be discharged from the rear end of the collection barrel, and the debris is intercepted in the collection barrel by the filter screen, which not only effectively reduces the impact on the surrounding environment, but also brings convenience to the cleaning work of later workers.

(3) The left and right sides of the placement plate are provided with limit plates, and the limit plates are slidably connected with the left column and the right column respectively, and the spacing between the two clamping plates on the placement plate can be adjusted. In this way, the placement plate can be moved back and forth without affecting the fixation of metal accessories, and then the opening operation can be carried out at different positions of accessories, which improves the flexibility of the device in use.

References

- [1] Zhao Xianghai Design and Research on automatic chip removal device of NC machine tool Journal of Shandong Yingcai college. Issue 03, 2019.
- [2] Liu Xiangting Common mechanical faults of CNC machine tools and preventive measures Equipment management and maintenance Issue 12, 2007.
- [3] Term interpretation mechanical design and manufacturing engineering. Issue 02, 2013.
- [4] Overview of chip removal methods in machining workshop [J] Shi Kangyun, Ma Jinfeng, Liu Yongkun Enterprise technology development. 2011 (20).
- [5] Analysis of chip removal methods in machining workshop [J] Qin Lili Light industry technology. 2014 (01).
- [6] Application of centralized chip removal system in machining workshop [J] Shi Kangyun, Ma Jinfeng, Liu Yongkun Group technology and production modernization. 2011 (03).
- [7] Determination of chip removal channel flow, negative pressure channel flow and split ratio of DF deep hole drilling system [J] Wang Zhiming Journal of Taiyuan Institute of mechanical engineering. 1987 (04).
- [8] Simulation study on chip removal performance of cluster reaming pneumatic impactor [J] Xu Hailiang, Zhou Yongxing, Xu Cong, Zhao Hongqiang, Xu Shaojun Vibration and shock. 2018 (18).