

Review on the research status of marine natural gas engine

Canze Ju*

Ealing International School, Shenyang, 1100002, China

* Corresponding author e-mail: luchagnhao@hrbeu.edu.cn

Abstract. with the ship emission becoming more and more strict and the shortage of oil resources, looking for clean alternative energy sources is imminent, natural gas with its high calorific value per unit, low exhaust pollution, reliable supply, economical advantages has become the preferred alternative fuel, and as the second trial production of combustible ice was successful, the development prospect of natural gas can be expected. This paper mainly introduces the research status of natural gas engine at home and abroad, the advantages of natural gas, focuses on the analysis of the emission of natural gas engine, so as to provide reference for its subsequent development.

Keywords: natural gas engine, research status, development.

1. Introduction

In recent years, with the continuous development of science and technology, people have gradually realized the importance of environmental protection, and the determination of global environmental pollution control has become more and more firm. A number of regulations have been issued successively, and the emission requirements of exhaust pollutants from ships in the field of international shipping have become more stringent. In the International Maritime Organization (IMO) MARPOL 73/78 Annex VI International Regulations for the Prevention of Air Pollution caused by Ships, strict requirements are put forward for the emission of NO_x, SO_x and particulate matter in the exhaust emissions of ships, which stipulate the sulfur content standard of fuel oil, NO_x emission standard of diesel engine and specific implementation schedule [1]. The SO_x emission control area is called SECA, and the NO_x emission control area is called NECA, collectively referred to as ECAs, as shown in Figure 1.

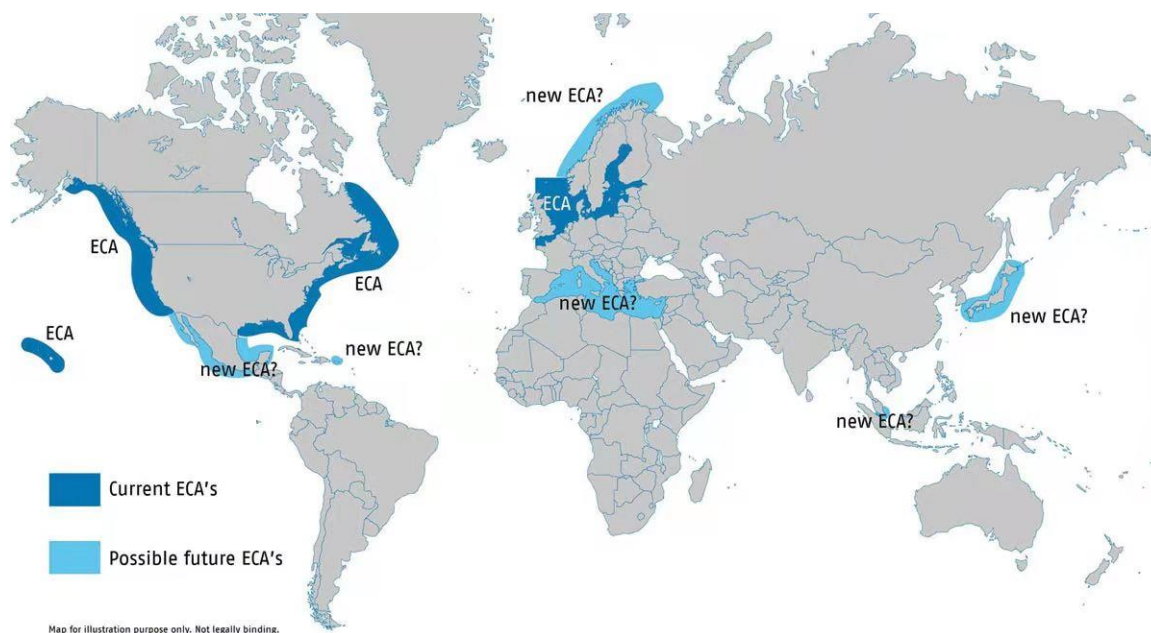

Fig. 1 IMO emission control area

At the same time, in the face of the current situation of the shortage of oil resources, as natural gas, coal and oil are the three major energy structures with balanced proportion in the world, natural gas

has become the key to make up for the lack of oil fuel. Compared with the world, the consumption of natural gas in China accounts for 7% of primary energy, less than a third of the global average (the global average is 24.6%) [2]. The imbalance of energy use ratio also greatly restricts the optimization of energy structure in China. With the success of the second trial production of combustible ice [3], China has conquered the key technologies of horizontal well drilling and production in abyssal shallow-soft strata, achieving a substantial increase in gas production scale and laying a solid technical foundation for productive trial production and commercial mining.

Based on this, the author analyzed the research status of natural gas engine, especially for Marine natural gas engine, and explored its development trend to provide a basis for the subsequent research and development of natural gas engine technology.

2. Nature of natural gas

Natural gas is a clean and environmentally friendly high-quality energy, consisting of methane (85%) and small amounts of ethane (3%), propane (3%) and butane (1%), among other substances. Because natural gas does not contain sulfur, its products almost have no sulfur dust and other harmful substances. When burning, sulfur produces less carbon dioxide than other fossil fuels, greenhouse effect is lower. At the same time, natural gas is safer than gasoline in many aspects, natural gas ignition temperature is higher than gasoline and diesel, in addition, natural gas is lighter than air, it will spread upward when leaking. Gasoline and diesel, on the other hand, accumulate in the ground, increasing fire risk and having a low year-on-year calorific value price compared to other fuels.

The burning calorific value of natural gas per cubic meter is 8000 kcal to 80005 kcal, and the burning value of liquefied gas per kilogram is 11,000 kcal, so it can be seen that the energy generated by natural gas per unit is relatively large. Compared with crude oil, the proved reserves of natural gas are much larger. At present, the ratio of known reserves to production of crude oil is about 40 years, while that of natural gas is about 60 years [4].

Among all alternative fuels, natural gas has been proven to be one of the most promising candidates for reducing anthropogenic carbon dioxide emissions by 20% per unit of energy produced, with the exception of fuel-ethanol blends, LPG and biodiesel, and produces almost no PM due to low METHANE C/H. Natural gas with high octane number and good anti-detonating quality can achieve high compression ratio and improve engine thermal efficiency. Natural gas burns clean. it contains almost no sulfur compared with gas and biogas, and combustion produces almost no SO_x. Table 1 shows the physical and chemical properties of natural gas and other alternative fuels [5].

Tab. 1 Physical and chemical properties of engine gas as alternative fuel

Fuel type Fuel properties	Natural gas	Coal gas	Biogas	Hydrogen
Octane number (RON)	130	—	About 125	35
Low calorific value MJ/kg	50.05	10.08	About 31	120
Flame propagation velocity C/H	35.6	42	About 24	About 300
Ignition limit %	5~15	0.247~0.332	—	0
Theoretical air-fuel ratio kg/kg	17.25	9.6~52.5	13.1~74.2	4.1~74.5
		2.45	5.81	34.3

3. Classification of natural gas engines

There are many types of Marine natural gas engines, which can be classified as follows according to different classification standards.

According to the fuel type, it can be divided into single gas fuel engine and dual fuel engine. Single gas fuel engine can also be called pure natural gas engine, no fuel oil mode, and the fuel is natural gas only. In dual fuel engines, there are two types of combustion modes: micro ignition and blending combustion. The engine can be used as a pure diesel engine or as a natural gas/diesel dual fuel, and can control the replacement rate autonomously.

According to the classification of natural gas supply mode, it can be divided into out-of-cylinder gas supply and in-cylinder direct injection. Out-of-cylinder gas supply can be divided into inlet mixer premixed engine, electronically controlled single point injection engine and electronically controlled multi-point injection engine. Cylinder direct injection can be divided into low pressure cylinder direct injection and high pressure cylinder direct injection.

In the early stage of development, a mechanically controlled mixer is used for the premixed air supply engine, which is the same as that of a gasoline engine, as shown in Figure 2. The gas supply device has simple structure, economical and practical advantages, but the drawback is that in the process of air intake, natural gas occupies the air filling volume of 10% - 15%, charging efficiency is low, and can't control accuracy of gas flow, which has an influence on the performance of the engine combustion, thus affect its performance and emission performance, which is not conducive to play the advantages of natural gas engines [6].

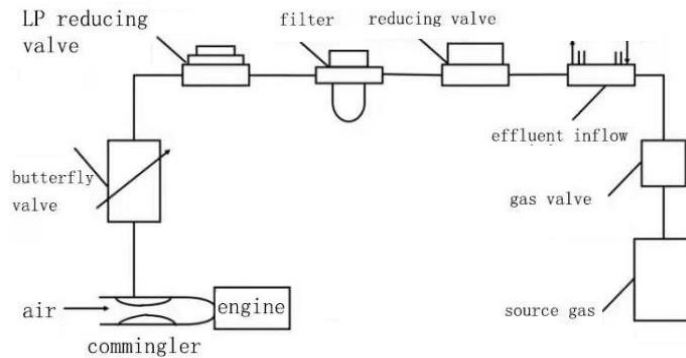

Fig. 2 Schematic diagram of mechanical control mixer

The way of electronically controlled single point injection is on the basis of mechanical gas inlet mixer modified, as shown in figure 3, the gas injection valve installed on the engine intake manifold, using the ECU to control the injection volume of injection valve, then through the intake manifold of natural gas distribution into each cylinder combustion to do work. This air supply mode has higher accuracy, better fuel combustion performance than the mechanical mixer mode, simple structure, low cost, reliable work, and convenient maintenance. However, in the intake process, it is impossible to control the amount of natural gas entering each cylinder, affecting the intake uniformity of each cylinder, and may lead to an increase in the frequency of partial fuel combustion and misfire under the condition of lean-burn, thus leading to an increase onHC and CO in the exhaust gas, resulting in poor engine power performance and emission [7].

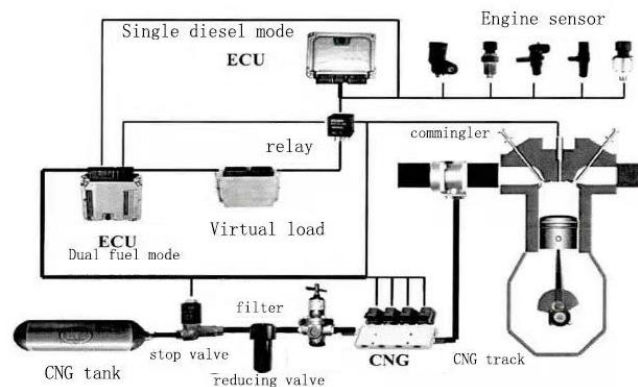

Fig. 3 Dual fuel mode gas fuel single point injection supply system

Electronically controlled multi-point injection engine means that an electronically controlled gas injection valve is installed in the intake manifold of each cylinder of the natural gas engine. The control system controls the injection timing and injection duration of the gas injection valve at each manifold to improve the mixture mixing in the cylinder, as shown in figure 4. The gas supply method can accurately control the amount of natural gas injection in each cylinder, improve the combustion and emission performance of the engine, and improve the quick response and accuracy of the engine under transient conditions. However, this kind of engine has a complex structure, high manufacturing cost and more complex control strategy in control system [8].

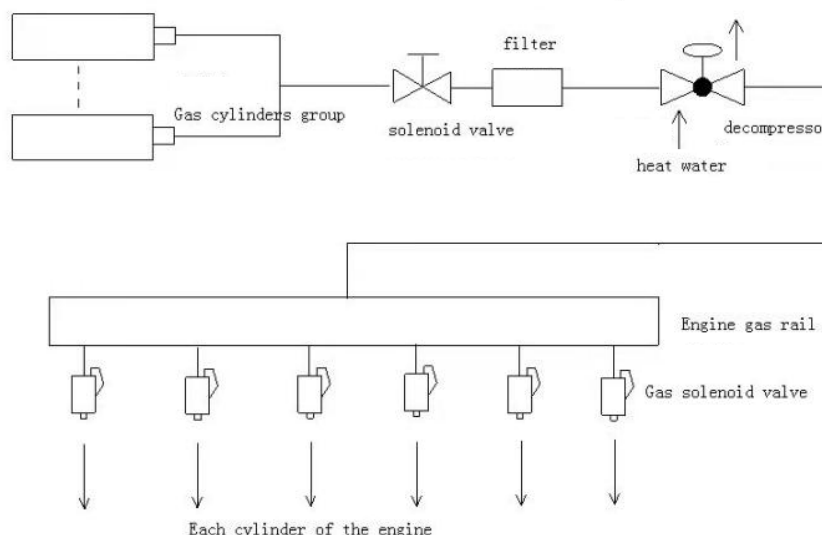

Fig. 4 Schematic diagram of multi-point injection gas supply system for marine natural gas engine

For cylinder direct injection engine, the gas injection valve is installed on the engine cylinder head, through the control of the injection valve, the fuel in the most appropriate time directly injects into the combustion chamber, through the design of the internal shape of the combustion chamber, so the mixture can produce strong eddy current, the air and fuel are mixed fully. The area around the spark plug achieves appropriate concentration stratification, thus ensuring as thin combustion as possible under the condition of smooth ignition. The advantage of this type of engine is to reduce the air filling quantity, which is conducive to the combustion and emission of the engine [9].

According to the ignition method of natural gas, it can be divided into ignited natural gas engine and diesel micro-ignited natural gas engine. Igniting natural gas engine technology is similar to gasoline engine, ignition time and energy are precisely controlled to achieve normal ignition; Diesel micro-ignition type natural gas engine is a multi-point ignition mode by preburning diesel fuel, forming a large number of fire nuclei and igniting the surrounding mixture.

4. Research status of natural gas engine

3.1 Development of natural gas engines

In the 1930s, the world's first engine powered mainly by natural gas was produced. After that, natural gas engines experienced three rapid developments. The first major development occurred after the second world war, because when oil become a kind of relatively scarce resource, in order to solve the problem of the application of the fuel, many countries began to use natural gas as an alternative fuel, at this point, a lot of natural gas are used on internal combustion engine, part of vehicle internal combustion engine used natural gas as a power source. However, due to the limitations of technology and production conditions at that time, the storage and carrying of natural gas are not convenient, so that after a long period of time, its development is very slow.

The second relatively rapid development occurred in the middle of the 1970s, after the Middle East war and oil crisis, many countries realized that the future development of the country should not

rely too much on oil resources, so natural gas was valued again. People began to realize that natural gas basically emits no black smoke after burning, and the environmental value of natural gas as a fuel has been recognized by people, which brings another development opportunity [10].

At the end of the 20th century and the early 21st century, a rapid development for the third time of natural gas engines, as global oil prices continue to rise, human demand for energy has increased dramatically, governments will greatly add the support to the development of alternative fuels for engines, natural gas is the most typical representative as an alternative fuel.

With the continuous development of science and technology, the technology of natural gas engine is constantly innovated, but at present, most natural gas engines are modified with diesel engine or gasoline engine, and the level of natural gas engine in various fields is uneven. In recent years, major enterprises and research units have carried out research on natural gas engine technologies, such as rarefied combustion technology and natural gas injection technology, in order to realize efficient combustion and clean emissions of natural gas engines.

3.2 Advantages and disadvantages of natural gas engines

Natural gas engines are mainly derived from natural gas. Compared with traditional fuel engines, natural gas engines have advantages of good economy, emission and higher safety.

Natural gas engines are more environmentally friendly than traditional fuel engines, which contain a large number of pollutants in their exhaust, including carbon monoxide, carbon dioxide and other harmful gas particles. The main composition of natural gas is methane, compared with traditional fuel oil, natural gas in oxygen can burn more fully, the engine emissions of carbon monoxide compared with the traditional use of fuel oil as a source of engine power can reduce by 90%, the emissions of nitrogen dioxide can reduce about 50%, sulfur dioxide and particulate matter emissions are also much lower than traditional fuel engines.

Although natural gas engines have obvious advantages, they also have some problems. First of all, the power of natural gas engine decreases obviously compared with fuel engine. Some experiments have shown that under the same conditions, engine power can be reduced by about 15 percent if natural gas is used as the main source of power, and in some special cases, engine power can be reduced by more. This phenomenon will increase the consumption of engine fuel, and in this case, the emission of substances that cause environmental pollution will increase, which is not conducive to environmental protection. The reason for this is that the characteristics of natural gas fuel itself and the structure of the engine itself, the physical properties of gas fuel itself cause the volume will account for a large proportion in the cylinder, and the volume of engine cylinder is limited, which reducing the volume of the air into the cylinder, air coefficient also decreases and the engine efficiency decreases.

Secondly, corrosion and early wear of natural gas engines are more serious. The reason for corrosion and wear is that the natural gas used contains impurities such as hydrogen sulfide and hydrogen sulfide gas, which will cause corrosion and wear of engine components. This results in relatively serious corrosion of engine combustion chamber components, and relatively serious wear of crankshaft, valve and piston ring in engine cylinder [11].

These problems can be ameliorated by some measures, such as improving the compression ratio of the engine, increasing the inflation coefficient of the engine, or using special engines, lubricants and other measures to improve the power, or through the desulfurization of the natural gas, or replacing the related materials of engines with corrosion resistant materials to reduce wear.

5. Analysis of exhaust pollutants from natural gas engines

The pollutants in exhaust gas of natural gas engine are basically the same as those of diesel engine, mainly carbon monoxide, non-alkane, methane, nitrogen oxides and ammonia. However, natural gas engines have unique combustion characteristics, and the generation of pollutants is different from that of diesel engines, so the emission control of pollutants is also different from that of diesel engines.

In the exhaust of natural gas engines, carbon monoxide is produced by inadequately burned fuel and can be treated by optimizing engine combustion and using oxidation catalytic converters. The main cause of methane in tail gas is incomplete fuel combustion, and the main cause of non-methane is non-fuel combustion. The treatment method of both is similar to that of carbon monoxide, which can be controlled by oxidation catalytic converter. For the control of nitrogen oxide emission, it is necessary to use the control technology of external purification device. Ammonia gas is mainly produced by the side reaction inside the post-processing system of natural gas engine, which can be controlled by means of ammonia escape catalytic converter or electronic control standard. The content of PM and PN in the exhaust gas of natural gas engines is low, which is the same order of magnitude with that in the atmosphere [12].

6. Conclusion

This paper summarizes the research status of natural gas engine, especially in Marine natural gas engines, from its classification, development course, advantages, disadvantages and analysis of the exhaust pollutants, we know that natural gas can be used as an alternative, with low fuel pollution and economic reliability, and the development trend of it as a preferred alternative fuel, It provides reference for the future research on related technology of natural gas engines, in order to achieve higher efficiency and less pollution of natural gas engine technology.

Reference

- [1] Zheng Zhongjin, Zheng Junyi. Analysis on Measures of Ships Dealing with "New Sulfur Limit Regulations" [J]. Fujian Transportation Science and Technology, 2019(03):137-139.
- [2] Wang Feng, XU Fengyin, Wang Fenglin. To accelerate the development of coalbed methane, the Contradiction between conventional energy and unconventional energy should be properly resolved: Current situation, existing problems and relevant suggestions of CBM business development of petrochina [J]. Journal of Beijing petroleum management cadre institute, 2019, 26(01):35-38+50.
- [3] The second round of trial production of natural gas hydrate has been successful [J]. Geological equipment, 2020, 21(03):3.
- [4] Dong Lin, LIAO Hualin, LI Yanlong, LIU Changling. Marine geology frontiers, 2020, 36(09):34-43.
- [5] Hoekstra R L, Collier K, Mulligan N, et al. Experimental study of a clean burning vehicle fuel [J]. International Journal of Hydrogen Energy, 1995, 20(9):737-745.
- [6] Xu Guoqiang, GAO Xiankun, Hou Ruijuan. Research on Gas Supply Technology of CNG/ Diesel Dual Fuel Engine [J]. Internal Combustion Engine, 2004(05):17-19+23.
- [7] Fang Shujuan, Tang Hailong. Science and Technology and Innovation, 2015(20):94+96.
- [8] Jiang Shangjun. Experimental Study on Control and Performance of Marine Natural Gas Engine [D]. Harbin Engineering University, 2019.
- [9] Huang Yingjie. Numerical Simulation study on Dual Fuel Injection and Combustion of Diesel In-cylinder Direct Injection Natural gas Engine [D]. Jiangsu University, 2019.
- [10] Zhang Yun, Mo Deyun, Cai Yan. Development history and Prospect of Natural Gas and gasoline Dual Fuel Engine [J]. Education and Teaching Forum, 2020(12):106-107.
- [11] Su Zhaorong. Research on Modification Technology and Calibration Test of LNG Vehicle [D]. Xihua University, 2013.
- [12] Li Ang. Research on Emission Characteristics of Equivalent Combustion Heavy Natural Gas Engine [D]. Jilin University, 2020.