

# The Technology and Development of New Energy Vehicles

Yuchen Wei<sup>1, \*, †</sup>, Manchen Huang<sup>2, †</sup>

<sup>1</sup>Wellington International School, Tianjin, China

<sup>2</sup>Quinte Christian High School, Belleville, Ontario, Canada

\*Corresponding author: yuchen.wei.2023@wellingtoncollege.cn

†These authors contributed equally.

**Abstract.** Due to CO<sub>2</sub> pollution, due to the energy saving and high efficiency of new energy vehicles, new energy vehicles have begun to develop at a high speed, and there is a hidden trend to replace traditional fuel vehicles. This paper will introduce hybrid vehicle (HEV), plug-in hybrid electric vehicle (PHEV) and electric vehicle (EV: including battery electric vehicle (BEV) and fuel cell electric vehicle (FCEV)) by type classification vehicle the characteristics and corresponding principles of these new energy vehicles. The motor and energy systems of different models are analyzed, the advantages and disadvantages of speed, energy efficiency, and distance of travel of the four types of new energy vehicles are compared, and the methods of improving the shortcomings of each model are explained.

**Keywords:** hybrid vehicle; plug-in hybrid electric vehicle; battery electric vehicle; fuel cell vehicle.

## 1. Introduction

New energy vehicles are defined as those that employ unconventional fuels as their primary source of propulsion, incorporate cutting-edge power control and drive systems, and establish an advanced technical principle using new structures and technologies. Four different types of hybrid electric cars (HEVs), pure electric vehicles (BEVs), and fuel cell electric vehicles are new energy vehicles (FCEV). In the current climate, when public opinion is at an all-time high and energy and environmental issues are getting more severe, energetically creating new energy vehicles is a practical solution. The operation of new energy vehicles may produce nearly no pollution, and they emit no hazardous substances that affect the atmosphere. Because power plants have faster rates of energy conversion and concentrated emissions may more readily fool emission control technology, even when electricity consumption is transformed into power plant emissions, they produce less pollution than ordinary automobiles. Additionally, the overall new energy vehicle employs new structural and technological advancements, increasing its efficiency.

## 2. HEVs

A hybrid vehicle is one that generates its own electricity from two sources. The two power sources are internal combustion engines and electric propulsion. A hybrid car combines an internal combustion engine with one or more electric motors that draw electricity from batteries to operate [1]. The main goal of these concepts was to create an emission-free, fuel-efficient automotive power source. The idea has been implemented successfully in a variety of vehicles, including pickup trucks, buses, and trucks [2].

Power is sent to the wheels of a hybrid car through the drive train. Parallel hybrids, series hybrids, power-split hybrids, and series-parallel hybrids are the four main types of hybrid designs.

An electric motor, an internal combustion engine, a generator, a battery, a power converter, and a transmission make up a hybrid car's basic powertrain configuration in parallel mode, shown in Fig. 1 [3]. In a parallel HEV, the internal combustion engine and the electric motor system are placed parallel to one another and operate together to propel the wheels. In addition, this system is more energy-efficient than HEVs set up in series. It may also provide quick power when a high-performance demand arises by using the electric motor to assist the internal combustion engine in

producing additional power. However, a complex linkage is required to connect the engine and electric motor shafts and provide combined power.

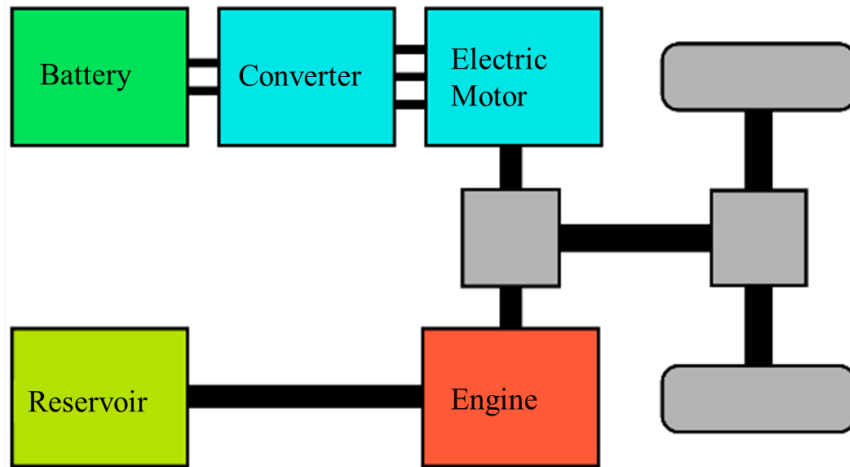

Fig. 1 Parallel HEV diagram

Since the wheels are entirely propelled by the electric motor in series, there is neither a mechanical link between the engine and the wheels nor a transmission. The engine is connected to a generator, and the electricity generated is used to charge a battery, which stores it, shown in Fig. 2. The controller feeds the electric motor that turns the wheels with power that is drawn from the battery. When the engine is off, a series HEV may run completely on its electric motor. A series hybrid vehicle is less efficient than a parallel hybrid due to the larger number of components, which increases energy losses.

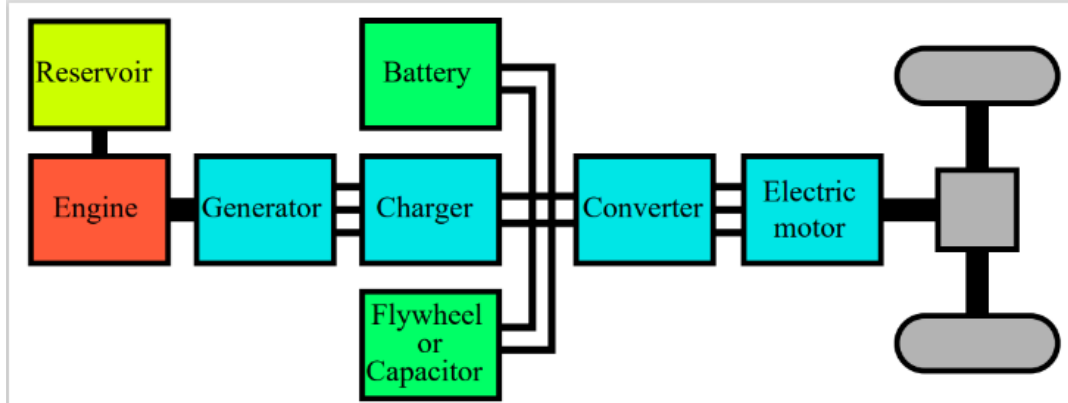
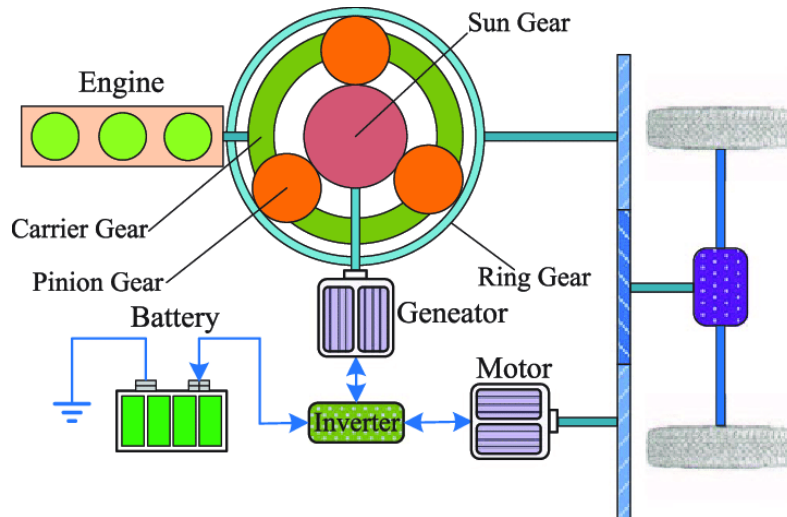

Fig. 2 Series HEV diagram

Power-split is the fusion of parallel and series HEV powertrains, shown in Fig. 3. The power-split HEV powertrain starts with the engine, which generates power that is then split in two ways: one connected to a generator, which produces electricity that is stored in a battery and then used to drive an electric motor connected to the transmission's rear, and the other connected to a generator, which produces electricity that goes directly into the transmission to drive the wheels like a conventional car. Both series and parallel methods are applied to maximise the vehicle's efficiency in a variety of driving circumstances. The fuel economy (32 km/l) is significantly higher than that of vehicles with conventional internal combustion engines. A 50–65 percent improvement is discernible.



**Fig. 3** Power-split HEV diagram

Complete and moderate HEVs are two further types of HEVs that rely on power sources, particularly electric power sources. When high performance is required, complete HEVs can have an independent power source, such as an electric propulsion system or an internal combustion engine (ICE), or both working in parallel to power the vehicle. Additionally, their electric battery is charged by the ICE, eliminating the need for external charging. They may also be operated in "Toyota Prius mode," in addition to parallel and series operation. Both the internal combustion engine and the electric motor operate in tandem to move the wheels. In series mode, the internal combustion engine serves as the main source of power while the electric motor supplements it to improve performance. Mild HEVs can only run partially on electricity, although they do have both electric and internal combustion engine (ICE) power sources. Instead, the vehicle mostly uses both power sources, however it may sometimes function with just the ICE. One such vehicle is the "Honda Accord Hybrid." [4]. They can only function in series mode due to the limitations of their parallel mode.

Because hybrids' electric motors produce less pollution than traditional automobiles, they are more fuel-efficient than those vehicles. They are also less costly and more economical than regular autos. Hybrid electric cars are now widely available thanks to the modernization and harmonisation of the technological route of automotive development. There is only one little drawback, but there are so many positives that it is barely necessary to explain them. The car is incredibly resourceful and ecologically friendly since it uses both oil and electricity as fuel, hence reducing fuel consumption and pollutants.

### 3. PHEVs

PHEV is a Plug-in hybrid electric vehicle. It is new resource vehicles between battery electric vehicles and fossil-fueled vehicles. It not only has traditional car engine, transmission, transmission system, oil circuit, fuel tank, but also has battery, electric motor, control circuit of battery electric vehicles, shown in Fig. 4. PHEV has larger battery capacity, usually people can drive over 50 km with battery mode. It combines the benefits of electric and hybrid electric vehicles, allowing for pure electric, zero-emission driving as well as an increase in driving range thanks to the hybrid mode.

In people's daily life, it can be used as electric vehicle if people drive under the limit distance of the battery. But as a result of the high price of battery, it is still hard to go into families with low price. As technology develop, the price will be lower and lower, maybe in the future people can afford PHEV for daily driving.

According to the proportion of motor driving power to the whole vehicle power, PHEV can be divided to four types. 1: a little bit of hybrid, mixing degree around 5% 2: Mild hybrid power, mixing degree around 20% 3: Medium hybrid power, mixing degree can be 30%-40% 4: Heavy hybrid power, mixing degree can be over 40%. There are also three main types of PHEV. First one is Tandem plug-

in hybrid, the engine does not drive the car directly, so the engine needs to drive the generator to generator electricity first, and then power the motive to drive the car. The energy transfer chain is long, and the overall efficiency is not high. The representative vehicle is BMW I3 extender. Second type is Parallel plug-in hybrid, both engine and motor can drive the car, it has more power transmission mode, better power performance, simple structure, widely used. It is the mainstream of the technical route. The representative vehicle is Byd Tang DM. The last type is Hybrid plug-in hybrid, generally, two motors (one generator and one motor) are required, as well as a planetary gear device for power splitting. This type has the most complex structure and controls. The representative type is Toyota PRIUS [4].

Plug-in hybrid has more battery capacity and can support a longer range than non-plug-in hybrid. If it is a short distance travelling, PHEV can be used as BEV (battery electricity vehicle), which is zero-emission driving. Also, if the power run out, people can still drive it with oil mode. But PHEV needs to have two power systems, one is electricity system and one is oil system. This makes it high cost for most people [5].

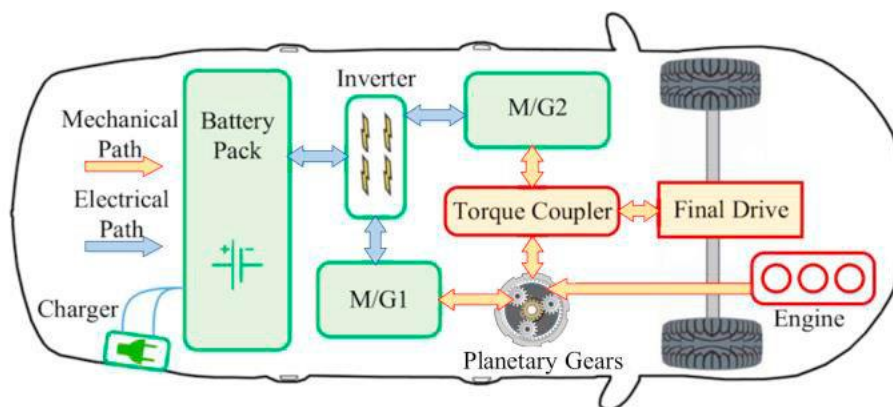

Fig. 4 The inside structure of PHEV

#### 4. BEVs and FCEVs

Electric vehicles are cars that are powered by batteries or supercapacitors, driven entirely or partially by electric motors. From the perspective of energy supply, electric vehicles can be divided into battery electric vehicles (BEVs), hybrid vehicles (HVs) and fuel cell vehicles (FCEVs). Only BEVs and FCVs are covered in this article. Battery electric and fuel cell cars are the final direction of the development of electric vehicles, which is an unavoidable tendency of the automobile industry's growth [6].

##### 4.1. BEV

Pure electric vehicles are provided by power batteries, and the current technology is relatively mature and can be industrialized for production and use [7].

Robert Davidson, an Englishman, created the first dry battery electric vehicle in 1838; Gaston Plantet, a French scientist, created the lead-acid battery in 1859; The first practical pure electric car was created by British scientist Robert Davidson in 1873 utilising a main battery motor and a secondary battery that could be recharged and discharged seven years later. Thomas Parker, a British manufacturer and inventor, created the first electric vehicle in 1884 using a large-capacity rechargeable battery; Engineer Kamilo Genatz from Belgium created the first pure electric car with an aluminium shell and a top speed of more than 100 km/h in 1899; Pure electric cars were increasingly replaced by gasoline-powered vehicles after the 1920s; The pure electric car industry commenced its second phase of significant growth at the start of the twenty-first century. Pure electric vehicles are composed of four parts: Electric drive control system, chassis, body, and auxiliary system [8].

#### 4.1.1 How BEV work

The motor controller drives the motor to generate power, and the torque output of the motor drives the wheels through the automotive transmission system, allowing the electric vehicle to move. The power converter is controlled by the signal electronic controller input from the accelerator pedal, which regulates the torque or speed of the motor output. The battery of the battery-electric vehicle is charged by the charger using the charging interface of the vehicle. A power converter connected to the electric motor powers the battery when the vehicle is moving [8,9].

#### 4.1.2 Power system

The battery management system should have the following functions:

- 1) Parameter detection: Real-time acquisition of battery charge and discharge status.
- 2) Remaining power (SOC) estimation Plan.
- 3) Control of battery charge and discharge: The battery's charge and discharge are regulated based on the electricity in the battery.
- 4) Thermal management: Real-time acquisition of the temperature of each pack of battery measurement points, through the control of the cooling fan to prevent the battery temperature is too high.
- 5) Balanced control: Because of the different states of use, the difference between the batteries will become larger and larger, and the system will automatically balance the processing.
- 6) Troubleshooting: Through the collection of battery parameters, the system has the functions of predicting battery performance, fault diagnosis and early alarm.
- 7) Information monitoring: The main information of the battery is displayed in real time at the on-board display terminal.
- 8) Parameter calibration: Since different models use different types of batteries, quantities, battery pack sizes and quantities, the system should have the function of calibrating information such as model, vehicle number, battery type and battery mode.
- 9) CAN bus interface: Information can be shared with other systems of the vehicle [9].

#### 4.1.3 Battery type and principle

There are two main types of batteries in battery electric cars, namely ternary lithium batteries and lithium iron carbonate batteries.

##### (1) Ternary lithium battery

Ternary lithium batteries are very efficient in both charging and discharging and have a high energy density. The main drawbacks of ternary lithium batteries are poor safety and short cycle life, especially safety performance, which has been limiting its large-scale matching, and large-scale integration applications are a major factor. At the same time, it also has the characteristics of not being resistant to high temperatures. Ternary lithium batteries are named after their cathode materials, because their cathode materials contain three metal elements of nickel, cobalt, manganese or aluminum, so they are named "ternary", shown in Fig. 5. Of these three elements, Ni and Co are active metals, and Mn does not participate in electrochemical reactions. In general, the higher the active metal content, the greater the battery capacity, which can greatly improve the energy density of the battery, which can also bring longer cruising range to electric vehicles. But when the Ni content is too high, Ni<sup>2+</sup> will occupy the position of lithium ions, exacerbating the mixing of cations, resulting in a decrease in capacity, and the battery is also more prone to thermal runaway, which will cause the material inside the battery to decompose and explode with the occurrence. Co is also an active metal, but it can act as an inhibition of cationic mixing, thereby stabilizing the layered structure of the material. As an inactive metal, Mn plays a stabilizing role in improving safety. According to a significant number of measured findings, ternary batteries with big capacities have trouble passing safety tests like needle punching and overcharge. For this reason, manganese components are typically added to large-capacity batteries, and even mixed lithium manganate is sometimes utilized.

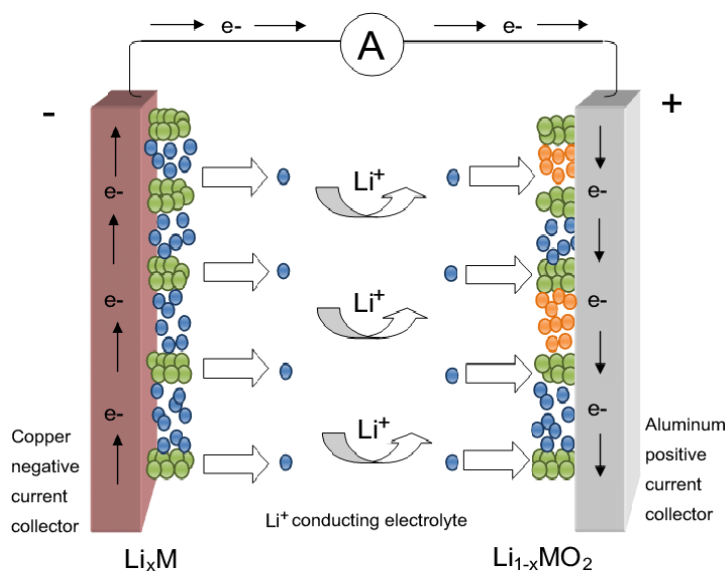

**Fig. 5** The structure of ternary lithium battery

(2) Lithium iron carbonate battery

Lithium iron phosphate is a typical orthogonal crystalline system, each unit cell contains 4 units, an octahedral FeO<sub>4</sub> and a tetrahedral PO<sub>4</sub> with two octahedral LiO<sub>6</sub> common prisms, such a structure allows lithium ions to move freely when charging and discharging. The positive electrode of a lithium iron phosphate battery, also known as a "iron lithium battery," is made of the olivine structure of FePO<sub>4</sub>; it is connected to the positive electrode by aluminium foil. The separator, made of a polymer, separates the positive electrode from the negative electrode, allowing only lithium ions to pass through while blocking electrons. On the right is the battery's negative electrode, which is made of graphite.

The electrolyte is located between the battery's top and lower ends, and it is enclosed in a metal casing. The lithium-ion battery gets its name from the lithium ions that move back and forth between the positive and negative electrodes during charge and discharge, shown in Fig. 6. When the battery is charged, the lithium ions in the positive electrode migrate to the negative electrode through the polymer separator; during the discharge process, the lithium ions in the negative electrode migrate to the positive electrode.

When charging, lithium ions detached from the positive LiCoO<sub>2</sub>, under the action of electric field forces, enter the electrolyte from the surface of the lithium iron phosphate crystal, pass through the diaphragm, and then migrate to the surface of the graphite crystal, and then embedded in the graphite lattice. Lithium iron phosphate is transformed into iron phosphate once the lithium ions are removed from it. When discharged, lithium ions migrate to the surface of the lithium iron phosphate crystal, detach from the graphite crystal, enter the electrolyte, pass through the diaphragm, and then re-embed into the lithium iron phosphate crystal's lattice.

The reaction that occurs on the positive electrode is:  $\text{LiCoO}_2 \rightleftharpoons \text{charging} \rightleftharpoons \text{Li}_{1-x}\text{CoO}_2 + x\text{Li}^{++} + x\text{e}^-$  (electronic)

The reaction that occurs on the negative electrode is:  $6\text{C} + x\text{Li}^{++} + x\text{e}^- \rightleftharpoons \text{Li}_x\text{C}_6$

enters the electrolyte, goes to the negative electrode while being affected by the charger's extra external electric field, and then enters the graphite- or coke-based negative electrode in turn, resulting in the formation of a LiC compound there [9].

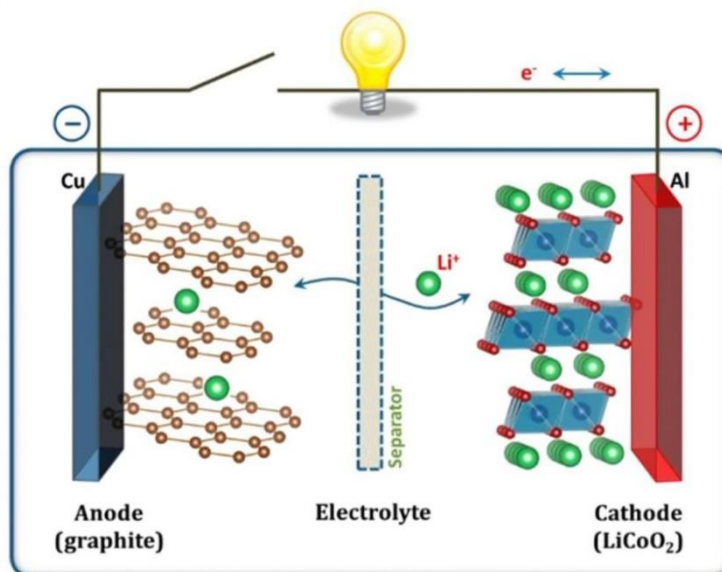

Fig. 6 The structure of lithium iron carbonate battery

## 4.2. FCEVs

In a fuel cell, electrochemical energy is produced using a power generation device at a constant temperature in accordance with chemical principles, without the generation of heat in the case of electricity produced directly from chemical energy conversion at the Carnot cycle limit, resulting in extremely high energy efficiency and minimal pollution. This makes fuel cells an ideal source of energy.

### 4.2.1 History of FCEVs

The phrase "fuel cell" was coined in 1889 by two scientists, Charles Long Court and Zhu Xinhua Monde. Francis Bacon created the first fuel cell apparatus in the world in 1932. Bacon and his colleagues created an inexpensive catalyst for a 5 kW fuel cell system as an alternative in 1959. Harry also created an inexpensive catalyst for the catalyst's function that same year [10].

### 4.2.2 How fuel cell vehicles work

A fuel cell is used as an electric vehicle's power source in a fuel cell electric vehicle (FCEV). The core of the fuel cell drive system is the fuel cell electric car. Its fuel type can range from hydrogen to methanol, and as a result, the associated power generating system is also diverse [10].

### 4.2.3 Power system

The power system of FCEV consists of:

- 1) Fuel cell stack: The fuel cell stack generates direct current (DC) through electrochemical reactions in the fuel cell.
- 2) Fuel processor: The fuel processor converts the fuel into a usable form of fuel cell.
- 3) Power conditioner: Power regulation includes controlling current (ampere), voltage, frequency and other current characteristics to meet the needs of the application.
- 4) Air compressor: In order to maximize efficiency and improve fuel cell performance, the input air pressure of an air compressor can be raised to 2 to 4 times that of the surrounding atmosphere.
- 5) Humidifier: The core polymer electrolyte membrane of PEM fuel cells does not work well when dried, so many fuel cell systems have humidifiers installed for the air intake [10].

### 4.2.4 Principle of cells

A positive and negative electrode (a negative electrode fuel electrode and a positive electrode oxidizer electrode) and an electrolyte make up the monomer battery of a hydrogen fuel cell, much like other batteries. According to the fuel cell's basic operating theory, hydrogen is converted into

electrons and hydrogen ions (protons) via a platinum catalyst in the positive electrode. where oxygen interacts to produce water and heat and protons go via the proton exchange membrane to the negative electrode. To create electrical energy, equivalent electrons go from the positive electrode to the negative electrode via the external circuit. Because the general battery's active ingredients are kept inside the battery, as opposed to other batteries, the battery's capacity is constrained. The positive and negative electrodes of the fuel cell itself are only a catalytic conversion component and do not include any active materials. As a result, fuel cells are actual devices for converting chemical energy into electrical energy. Fuel and oxidizer are provided by the outside environment and respond while the battery is operating. The fuel cell may theoretically continue to produce power as long as reactants are constantly imported and reaction products are disposed of. Here, the hydrogen-oxygen fuel cell is used as an example to show how the fuel cell's reaction principle works. The electrolysis of water is reversed in this reaction. The electrode should be a negative electrode made of the fuel cell's basic material,  $H_2 + 2OH^- + 2e^-$ .

One of the essential components of fuel cells is the catalyst, whose functions include lowering the reaction's activation energy, encouraging the redox interaction between hydrogen and oxygen on the electrode, and speeding up the reaction.

Proton exchange membrane is a polymer electrolyte membrane, which plays an important role in conducting protons, isolating cathodes and anode reactants in fuel cells, and is also used as a catalyst support body when preparing CCM membrane electrodes, which is the core device of fuel cells and a key component that determines the performance, life and cost of fuel cells. In practical applications, proton exchange membranes are required to have high proton conductivity and good chemical and mechanical stability [10]. Fig. 7 shows the energy systems for fuel cell electric vehicles.

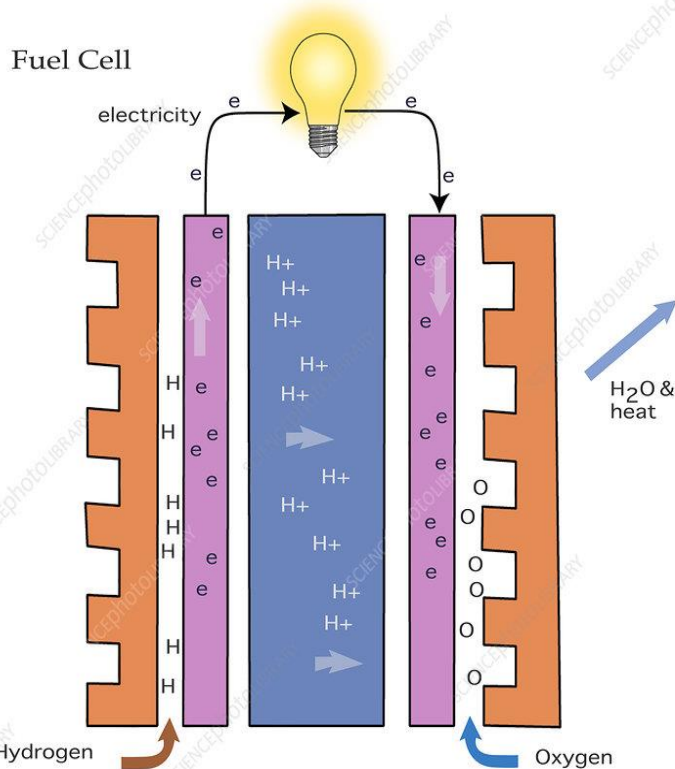

**Fig. 7** Energy systems for fuel cell electric vehicles

The electric motors are a key part of BEV and fuel cell vehicles, accounting for a higher proportion of the total vehicle cost, and are also the main differences between electric vehicles and other types of vehicles and it is also the similarity between BEV and fuel cell vehicles. Therefore, this research will focus on the electric motor of the two models.

### 4.3. Electromotor

#### 4.3.1 General principle of electromotor

Electric motors are mechanical devices that can change mechanical energy into electrical energy and vice versa. The term "electric motor" refers to a device that generates energy in addition to serving as the primary means of propulsion for an electric vehicle.

Asynchronous motors and permanent magnet synchronous motors are the two motor types most frequently utilised in electric cars [11].

#### 4.3.2 Types and characteristics of electric motors

The AC asynchronous motor (shown in Fig. 8) is a particular kind of motor made up of a rotating magnetic field created by the stator winding and a magnetic field created by a current generated in the rotor winding, which interact physically to produce electromagnetic torque that propels the driver's rotation. First of all, because the rotor in the asynchronous motor is always "catching up" the speed of the stator rotating magnetic field, and in order to be able to cut the magnetic induction line and generate induced current, the speed of the rotor is always a little slower than the speed of the stator rotating magnetic field, that is, asynchronous operation, so the motor that generates the induced current is called an AC asynchronous motor. It is precisely because of the infancy that the difference in rotation occurs, which causes the conductor on the rotor to generate an electric current, which rotates under the force in the magnetic field. It is also for this reason that its control is slightly more complicated. However, the induction motor is composed of a coil and a rotor core, so the price is cheap, the overload capacity is strong, the leather is durable and the performance is excellent [11].

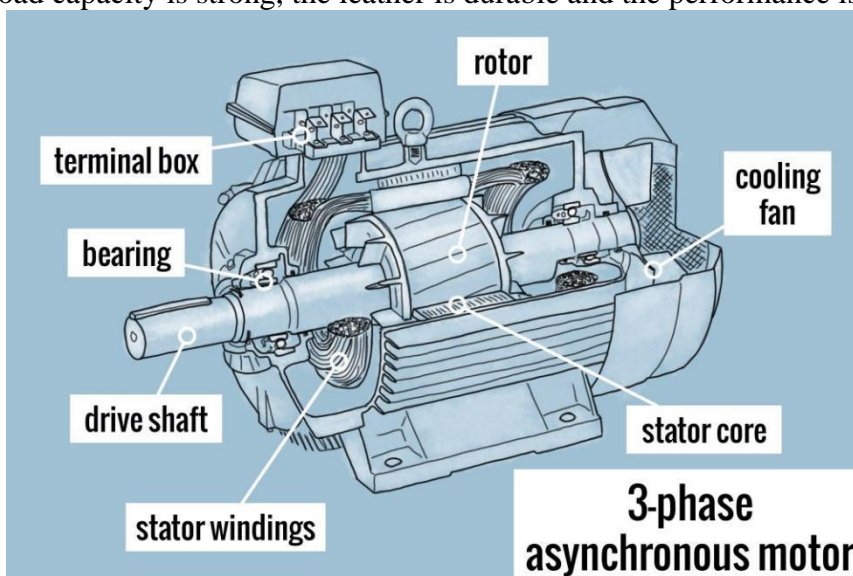

Fig. 8 AC asynchronous motor

Permanent magnet synchronous motor (PMSM) to permanent magnet to provide excitation (excitation: the magnetic field on which the motor works), no brush, no excitation current, improve the efficiency and power density of the motor.

Permanent magnet synchronous motors (shown in Fig. 9) are generally composed of: stators, rotors, end caps and other components. The stator winding, which surrounds the stator core, controls the frequency of the input current of the stator winding, and then controls the rotational speed of the magnetic field. The rotor is placed on the permanent magnet (NdFeB), high magnetic performance NdFeB under the control algorithm stability performance and wide application, increase the reliability and stability of the permanent magnet, can better reduce the occurrence of demagnetization phenomenon. The working mode of permanent magnet synchronous motor is divided into two types: one is to control the motor to achieve synchronization through the frequency converter governor, and the other is to achieve synchronization by asynchronous starting. Frequency conversion governor mode

The frequency conversion governor supplies the power to the permanent magnet synchronous motor, and when it starts, the output frequency of the converter rises steadily from 0 to the working frequency. The motor speed increases synchronously with the output frequency, and the output frequency of the converter can change the motor speed, making it a good frequency conversion speed regulation motor.

The magnetic field produced by the stator winding, the rotor cage winding, and the permanent magnet combine to provide the start and operation of the permanent magnet synchronous motor.

The method of directly supplying power with a three-phase alternating current in the absence of speed regulation is to install a cage-type winding on the permanent magnet rotor. At rest, a given submitting is fed into a three-phase alternating current, generating a stator rotating magnetic field; The stator rotating magnetic field is equivalent to the rotor rotation, which generates an induced current within the cage windings to form a rotor rotation magnetic field. These two magnetic fields interact to produce a torque so that the rotor starts to rotate from stationary. At the beginning of the rotation, the speed of the rotor rotation magnetic field and the speed of the stator rotating magnetic field are not equal, which will produce an alternating torque. When the rotor rotation magnetic field is almost synchronized with the stator rotating magnetic field, the rotor windings do not generate induced current, and only the permanent magnet on the rotor generates a magnetic field, generating a driving torque. Therefore, the rotor windings achieve a start-up, and after the start-up is completed, the rotor windings no longer function, and the magnetic field of the permanent magnet and the stator winding interacts to generate a moment [12].

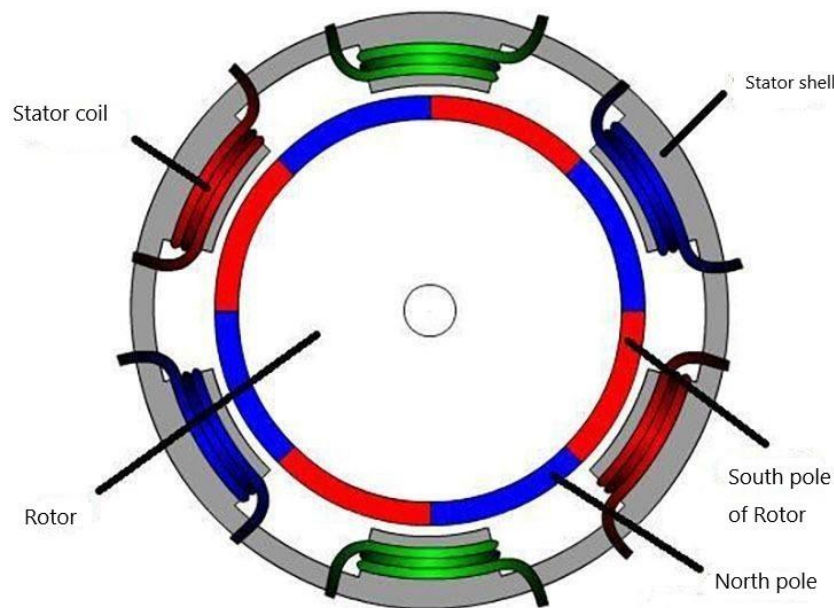

**Fig. 9** Permanent magnet synchronous motor

#### 4.3.3 Comparison and application of the two motors

Asynchronous motors: High structural strength; Low drag loss; High safety at high speeds; Low cost. Permanent magnet motor: high power factor; High efficiency at low speeds; Fast torque dynamic response; High power density. All in all, asynchronous induction motors have high explosive power, and permanent magnet motors have stronger endurance. This benefits from the dual-motor mechanism that electric vehicles can have, which allows two motors to work together at the same time. Because the induction motor does not have a permanent magnet magnetic field, there is no need to consume power to offset the resistance when idling, thereby reducing energy consumption and increasing endurance. So this makes electric vehicles have both high outbreak and long-term endurance [11-13].

## 5. Conclusion

Advantages of HEV are that the main role of the motor of the hybrid model is to make up for the shortcomings of the fuel vehicle at the start, the fuel economy performance is high, and the driving performance is superior, the engine of the ordinary hybrid vehicle should use fuel, and when starting and accelerating, due to the assistance of the motor, it can reduce fuel consumption.

Disadvantages of HEV are that ordinary hybrid models do not support direct charging of vehicle batteries, battery capacity is small, compared to the price of cars will be high, especially now that the state has canceled the subsidy policy.

Advantages of PHEV are that the plug-in hybrid vehicle's battery is reasonably big, can be charged externally, can be operated in pure electric mode before switching to hybrid mode (mostly using an internal combustion engine) after the battery is depleted, and can be charged quickly. Additionally, it charges considerably more quickly than an all-electric vehicle.

Disadvantages of PHEV are that if it cannot be guaranteed to be recharged enough, the car itself will have a heavy battery. Moreover, the cost of such cars is also higher, and the structure is more complex than that of pure electric vehicles.

Advantages of BEV are that since just electricity is used to power them, pure electric cars are not only more affordable structurally than other new energy vehicles, but also significantly less expensive on a daily basis to maintain.

Disadvantages of BEV are that it is evident that an electric vehicle's range is somewhat restricted due to the lack of power and the necessity to find charging stations. Additionally, charging an electric vehicle takes significantly longer than recharging a conventional vehicle.

Advantages of FCEVs are reduced greenhouse gas emissions, an unlimited supply of power sources, and pollution-free operation. Within five minutes, the battery may be refuelled, and the battery life is improved.

Disadvantages of FCEVs are that there are issues in all areas of hydrogen storage, including the price of constructing hydrogen stations, the security of hydrogen storage, etc., which need to be taken into consideration further. This sort of automobile is too expensive and not suited for commercial use. To improve the weakness of HEV. A new type of battery need to be research and develop, it need to has better efficiency and reliability as battery is the key of HEVs, which would also improve batteries storage capacity.

To improve the weakness of PHEV, rational design of hybrid scheme, integrated design of power systems, specialized design of core components needs to be done. Also, new special purpose engines, automatic transmission needs to be developed.

Battery electric vehicle history, short charging slow problem can be taken to build a replacement power station method to improve, do not need to wait for the full charge, only need to use the machine site to remove the battery without power, and install a fully charged battery, and the replacement of the battery will continue to charge, the maintenance personnel need to regularly check the status of all batteries to ensure that the battery is not faulty.

In order to prevent the vehicle from deforming in the event of a rear-end accident, the high-pressure hydrogen storage tank breaks the hydrogen gas and leaks out, causing danger. Highly pressure hydrogen storage tanks that are both lightweight and impact resistant can be used. The hydrogen storage tank is a three-layer structure, with a surface layer (outermost) of glass fibers, and a middle layer consisting of reinforced plastic wrapped in carbon fibers also used on the aircraft, enhancing strength and durability. Even in the event of a strong impact on the body such as a rear-end collision, the body absorbs the impact and is designed to protect the rear high-pressure hydrogen tank. In addition, the valve of the high-pressure hydrogen storage tank will automatically close when the impact is detected and sensed, blocking the flow of hydrogen.

## References

- [1] "Alternative Fuels Data Center: Hybrid Electric Vehicles". Afdc.Energy.Gov, 2022, [https://afdc.energy.gov/vehicles/electric\\_basics\\_hev.html](https://afdc.energy.gov/vehicles/electric_basics_hev.html).
- [2] Yagnesh Bapodra and Udayakumar Rajamanickam 2021 IOP Conf. Ser.: Earth Environ. Sci. 633 012007.
- [3] Shafiee, S, Fotuhi-Firuzabad, et al. Investigating the Impacts of Plug-in Hybrid Electric Vehicles on Power Distribution Systems. IEEE Transactions on Smart Grid, 2013, 4(3):1351-1360.
- [4] Wang J . Analysis on the application status of plug-in hybrid electric vehicle. Energy Conservation & Environmental Protection in Transportation, 2016.
- [5] Yan P R , Tao Y F , Qing-Lin Y E , et al. Energy-saving and Environment-friendly Vehicle: Plug-in Hybrid Electric Vehicle. Mechanical Engineering & Automation, 2015.
- [6] diandongbang, <https://www.diandong.com/zixun/37933.html>2016-07-11
- [7] Zhang W L , Bin W U , Wu-Feng L I , et al. Discussion on Development Trend of Battery Electric Vehicles in China and Its Energy Supply Mode. Power System Technology, 2009.
- [8] Nan J , Sun F , Wang J . Electric vehicle battery management system. Journal of Tsinghua University(Science and Technology), 2007, 45(86):636 - 639.
- [9] Analysis of advantages and disadvantages of pure electric vehicles and introduction of basic institutions Liu Xin Xi'an Automobile Vocational University, Xi'an, Shaanxi 71060 1006-8554.2019.11.024, CD8FA5A2-D4D4-40D2-A14D-8D24414791C5.pdf
- [10] Yu Z , Luo Y , Shen Z . Research on Fuel Cell Technology of Electric Vehicle. 2017, 001(001):P.23-30.
- [11] NIO, [https://app.nio.com/app/web/v2/share\\_comment?id=1060847&type=essay](https://app.nio.com/app/web/v2/share_comment?id=1060847&type=essay), 2020-12-07
- [12] NIO, [https://app.nio.com/app/web/v2/content/1421778712?load\\_js\\_bridge=true&show\\_navigator=false&content\\_type=article&ADTAG=wechatfriend&share\\_uid=UIFYLiOsJaEoxcZunEsloA](https://app.nio.com/app/web/v2/content/1421778712?load_js_bridge=true&show_navigator=false&content_type=article&ADTAG=wechatfriend&share_uid=UIFYLiOsJaEoxcZunEsloA), 2019-03-18
- [13] ]NIO, [https://app.nio.com/app/web/v2/content/1711075483?load\\_js\\_bridge=true&show\\_navigator=false&content\\_type=article&ADTAG=wechatfriend&share\\_uid=UIFYLiOsJaEoxcZunEsloA](https://app.nio.com/app/web/v2/content/1711075483?load_js_bridge=true&show_navigator=false&content_type=article&ADTAG=wechatfriend&share_uid=UIFYLiOsJaEoxcZunEsloA), 2022-07-29