

Computer statistical and big data analysis on the comparisons between traditional engine, electromotor, and hybrid systems

Zijie Dai^{1, a, †} and Jiacheng Ye^{2, *, †}

¹Father John Redmond C.S.S&R.A.C, Toronto, Ontario, CA;

²Physics, Aquinas International Academy, La Palma, California, 90623, USA.

*Corresponding author e-mail: smy@hrbeu.edu.cn, ^aWenshengdai128@gmail.com

†These authors contributed equally.

Abstract. This paper aims to discuss and differentiate conventional engines such as gasoline and diesel driven engines versus electric motor and hybrid engines. In the modern-day, various concepts are introduced to produce and invent automobiles that will lessen the impact on the environment and implement sustainability. To understand their differences, this paper will tackle all the basic components of each engine concerning their working principle, efficiency, capacity, and the characteristics of power and torque. The entire project is based on comparison to determine the benefits of various engines. Through various research and investigations, it can be found that electric motors have more advantages than internal combustion engines, such as higher than 90% efficiency, zero environmental pollution or small pollution, more powerful power, lower use and maintenance costs. However, while electric vehicles are full of advantages, disadvantages cannot be ignored. The mileage is limited, and there are fewer charging stations and fewer models to choose from on the market. Because of various advantages and disadvantages, diesel locomotives and electric vehicles will coexist in a short time, but in the future electric vehicles will dominate and lead a more efficient life.

Keywords: internal combustion engine, electromotor, hybrid vehicle, efficiency.

1. Introduction

1.1. General Introduction

This essay analyses the characteristics of traditional engines, electromotors and the concept of hybrid vehicles. The whole project is based on comparisons and finally concludes the advantage of different engines, which may lead to a more efficient lifestyle in the future.

1.2. Introduction of internal combustion engine

Electric vehicles once occupied a large market a hundred years ago, but they were gradually replaced by internal combustion engines. The internal combustion engine appeared at the beginning of the automobile industry. Automobiles have gradually become popular in society. People want to travel by car instead of just being used as a means of transportation in the city for short distances. The internal combustion engine has no distance limitation and has attracted countless people, and it has gradually become the primary source of power for passenger cars. At the same time, the discovery of many oil resources has made oil prices very cheap, so the shortcomings of internal combustion engines such as low efficiency, high noise, and environmental pollution have been ignored by people. However, as society has paid more and more attention to environmental pollution and energy consumption in recent years, electric vehicles have become the future development direction.

1.3. Introduction of electric motor

As a new type of engine, electric motors have attracted a lot of attention. Compared to traditional internal combustion engines, electric motors are more efficient, lower cost of use and more environmentally friendly. In the era of environmental protection, these advantages meet the needs of consumers and society. New electric cars companies such as Tesla have created a huge competitive

pressure on some giants in the traditional auto industry. Some countries will completely replace their existing traditional fuel cars with electric vehicles in the future. This article will start from the principle of electric motor, working efficiency and other aspects, a detailed analysis of electric motors compared with the advantages and disadvantages of traditional engines. Let the reader fully understand and have a new view of electric motors. In the future, electric vehicles will overcome some of the current shortcomings and become the leader of the engine industry.

2. Mechanism

Systematic use of quantitative methods to describe the unique characteristics of petrol, diesel, electric and hybrid engines is best and sustainable by collecting published research and literature. The data in the charts are interpreted and selected by reference to reliable published research papers and organizations relevant to the topic. So, this is a more acceptable way of doing research because the engineers in the automotive industry are ahead and the data comes from them.

3. Discussion

3.1. Basic principles and some background

Two hundred years ago, when the steam engines appeared, human beings started to use the power of thermodynamics to produce work and boost the efficiency in every field. From the steam engine to the internal combustion engine used contemporarily, although the efficiency has increased from only 10% to 40%, it cannot even reach 50%. First, the concept of efficiency needs to be stated.

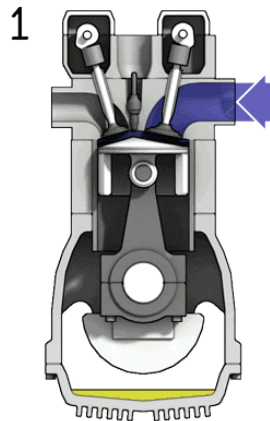

Figure 1. Four stages of IC engine

More precisely, the “efficiency” is composed of thermal efficiency, mechanics efficiency and combustion efficiency. As both mechanics and combustion efficiency can reach 90%, the main element affects the thermal efficiency. Equation (1) defines it:

$$\eta = \frac{W_{out}}{Q_{in}} \quad (1)$$

It means that, only one-thirds of heat can be transferred to output work; and the total efficiency can be defined as:

$$\eta_{total} = \eta_{th}\eta_{mech}\eta_{com} \quad (2)$$

So where is the other heat? Some is taken away by the cooling water and other is wasted when being exhausted. The efficient work be used is only 30%-40%.

We have the concepts to explain why there is a limit of percent conversion: the second law of thermodynamics. When transferring energy of low quality like heat to energy of high quality like mechanical energy, the efficiency is impossible to be 100% and what gives the certain value of this limit is the Carnot cycle efficiency.

Here I will just use the conclusion of Carnot cycle:

$$\eta_{carnot} = 1 - \frac{T_{low}}{T_{high}} \quad (3)$$

The internal combustion engine can reach 2500K and the normal temperature is 300K so the maximum efficiency is about 85%. But the answer is far larger than the actual efficiency. The reason is that the internal combustion engine cannot be expressed by the Carnot cycle, but by Otto cycle. The air standard Otto cycle is an ideal cycle that assumes heat addition occurs instantaneously while the piston is at top dead centre. It is composed of four stage, which we can find on the p-v diagram.

[1 to 2] isentropic compression, when the piston moves from the bottom dead centre to the top dead centre;

[2 to 3] constant volume heat transfer to the air from external source when the piston is at the top dead centre

[3 to 4] isentropic expansion, when the piston does work.

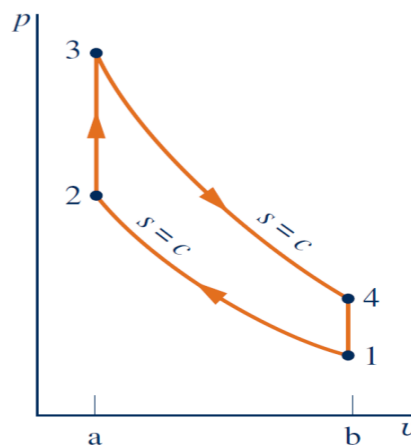

Figure 2. P-v diagram of Otto Cycle [8]

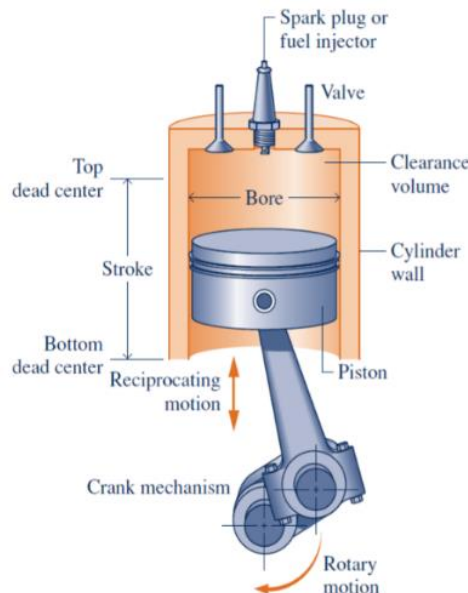

Figure 3. Structure of engine [8]

[4 to 1] constant volume heat transfer when heat is rejected from the air when the piston is at the bottom dead center. [8]

These four stages are just an approximate expression of the stages of the internal combustion engine, and some realistic problems have not been considered, which we need to be careful about.

Leaving out the derivation, which can be found in books about thermodynamics, the efficiency equation of Otto cycle is:

$$\eta_{otto} = 1 - \frac{1}{r^{\gamma-1}} \quad (4)$$

In which “r” represents the compression ratio, about one-tenths and “γ” represents the specific heat ratio, about 50%. Using the data, we know that the theoretical value of the engine is about 50%, far away from the Carnot efficiency.

Carnot efficiency is the theoretical maximum value of an engine, so through research and thousands of experiments, theoretically, the efficiency of traditional engine could be higher. To increase the efficiency, based on the knowledges above, human beings need to figure out the way to organize a perfect process of combustion or redesign the constructure of the engine to increase the efficiency. All in all, however, we cannot expect the efficiency to be increased enormously because of the characteristics of heat, a kind of energy of “low quality”, which we have mentioned before.

Internal combustion engines are divided into two major types, which can be distinguished from the kind of fuel and the way of ignition. SI (Spark Ignition) engine uses gasoline, due to homogeneous combustion, gasoline engine makes less harmful emission, less vibration, and more range of RPM, which can run higher speed. So, it usually installs on the passage car. Another type is the CI (Compression Ignition) engine, it uses diesel as the fuel. Diesel engines are usually installed on semi-truck, heavy duty machine, and marine, principle is to compression the fuel to ignition. Although gasoline engines have the advantages of being lightweight, low emissions, and high engine speeds, they have lower thermal efficiency than diesel engines. The thermal efficiency of a diesel engine is 30% higher than that of a gasoline engine, so the average MPG is 30% higher. At the same time, diesel engines can burst out powerful torque at low engine speeds, at lower cost, and can run under full load for a long time, so they are widely used in heavy-duty, trucks, marines.

The principle of an electric motor is not complicated. You can think of it as an electric machine that converts electrical energy into mechanical energy.[3] When a wire is placed in a magnetic field and an electric current is applied to the wire, the current enters the coil and produces a magnetic field. A device that uses the magnetic effect of the current to make the electromagnet rotate continuously within a fixed magnet can convert electrical energy into kinetic energy. The basic structure of an electric motor is mainly composed of stator and rotor. The stator is stationary in space, while the rotor rotates on an axis and is supported by bearings. There is a certain air gap between the stator and rotor to ensure that the rotor can rotate freely. There are two ways to power an electric motor, one is direct current such as batteries or rectifiers, the other one is alternating current sources such as a power grid.



Figure 4. These two pictures show the basic internal structure of a motor

3.2.1 Efficiency

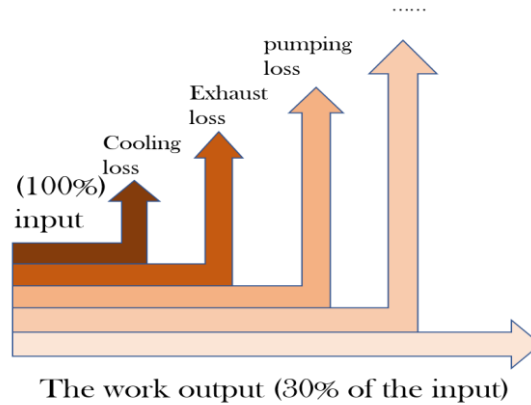

Figure 5. The energy conversion process of an internal combustion engine

As we know from the previous introduction of the internal combustion engine, the output efficiency is only 30% to 35% of the input efficiency due to the loss of energy in cooling, exhaust and also friction. Electric cars convert more than 85% of energy into mechanical energy. At the same time, electric vehicles can transfer 59%-62% of energy from the grid directly to the wheels for the vehicle to run, while traditional fuel vehicles can only transfer 17%-21% of energy.[1] Electric motors are at least three times more efficient than internal combustion engines. Electric motor efficiency tends to drop sharply below 50% of the load. However, the range of good efficiency varies by individual motor and tends to expand to a larger motor range.

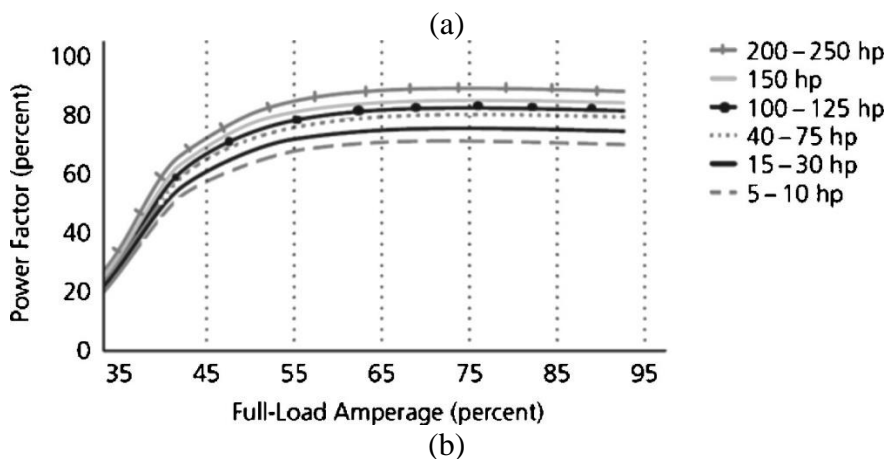
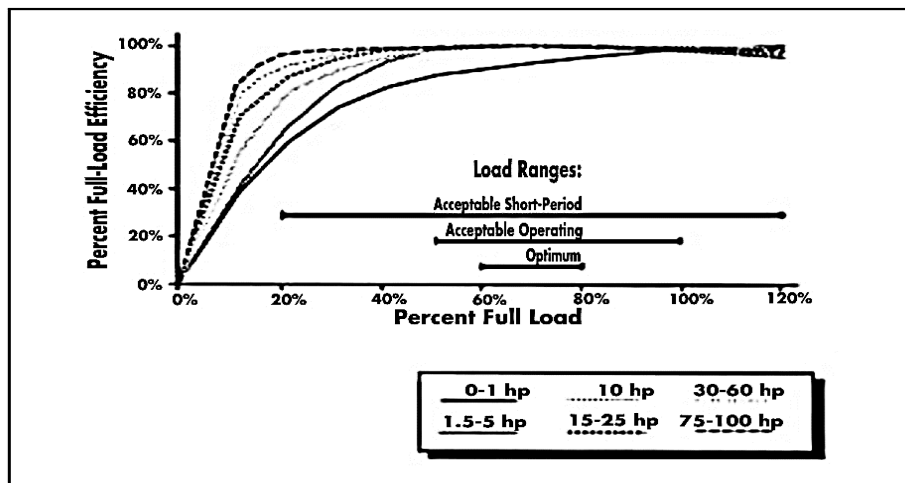

Figure 6 the efficiency range of electromotors [1]

As shown in Figure 6. A motor is considered underloaded when its efficiency decreases significantly as the load decreases. As can be seen from Figure 7, as the load decreases, the power factor decreases faster, but more slowly than the efficiency. [4]

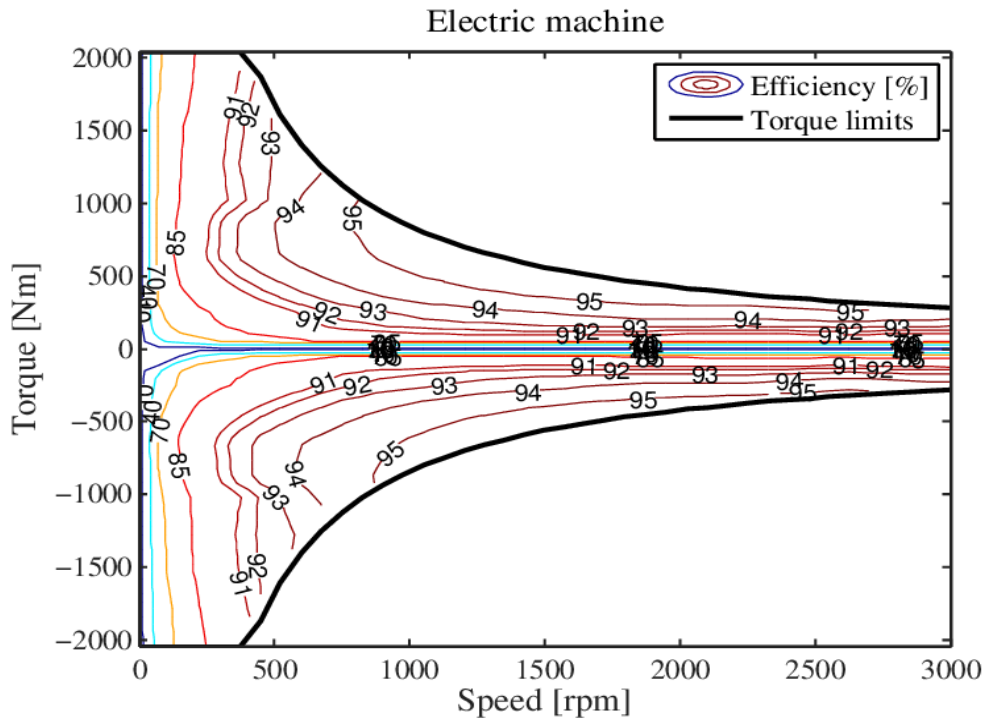

Figure 7. The speed and torque graph of electromotor

The efficiency of the electric motor as a function of the torque and speed. For positive torques, the EM operates in motoring mode; when the torque is negative, the EM operates as a generator and produces an electric energy that is stored in the battery. [5]

3.2.2 Equation and Goodness factor

$$\eta = \frac{P_m}{P_e} \quad \begin{matrix} P_e = IV \\ P_m = T\omega \end{matrix} \tag{5}$$

Here is the equation of electric motor’s efficiency. In this equation, P_e is electrical input power, P_m is mechanical output power. During my search, there is an equation to calculate the Goodness Factor of an electric motor.

$$G = \frac{\omega}{\text{resistance} \times \text{reluctance}} = \frac{\omega \mu \sigma A_m A_e}{l_m l_e} \tag{6}$$

From this equation we know that the most efficient motors are likely to have relatively large magnetic poles. This equation directly relates to non-PM motors.

3.2. Data and image analysis (thermodynamic)

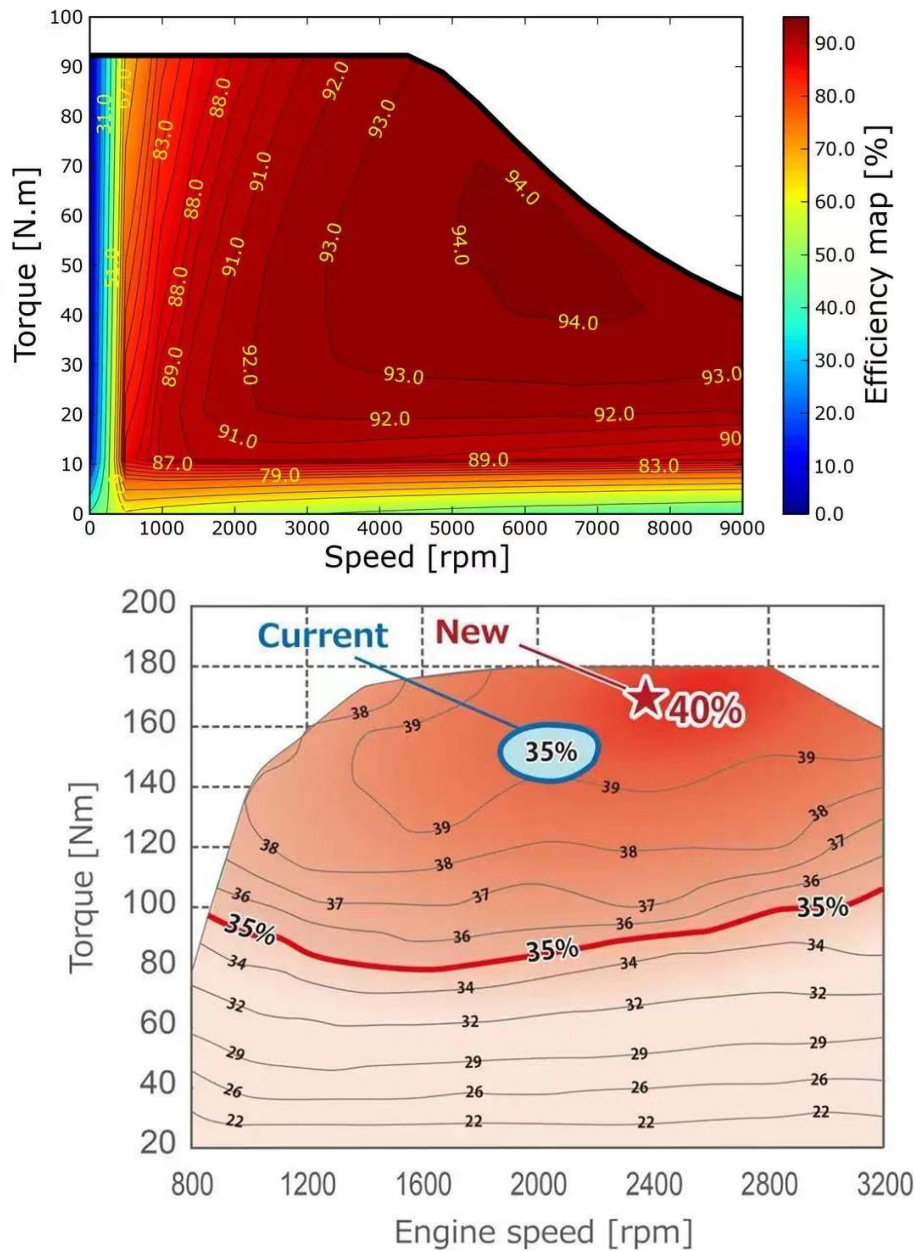

Figure 8. The efficiency range of electromotors and IC engines [6]

These two graphs respectively show the efficiency range of the electromotor and IC engine. The IC engine can reach the maximum (40%), but only at a certain engine speed. However, compared with the IC engine, the electromotor is far better. When the rotational speed is around 6000rpm and torque is about 60Nm, the efficiency reaches the maximum 94%. That is similar to the situation when the vehicle is starting. Actually, no matter in which range, the efficiency of the electromotor is extremely high. Even by using the speed change box, the IC engine still cannot achieve even half of the efficiency of an electric motor. [4]

3.3. Well-to-wheel comparison

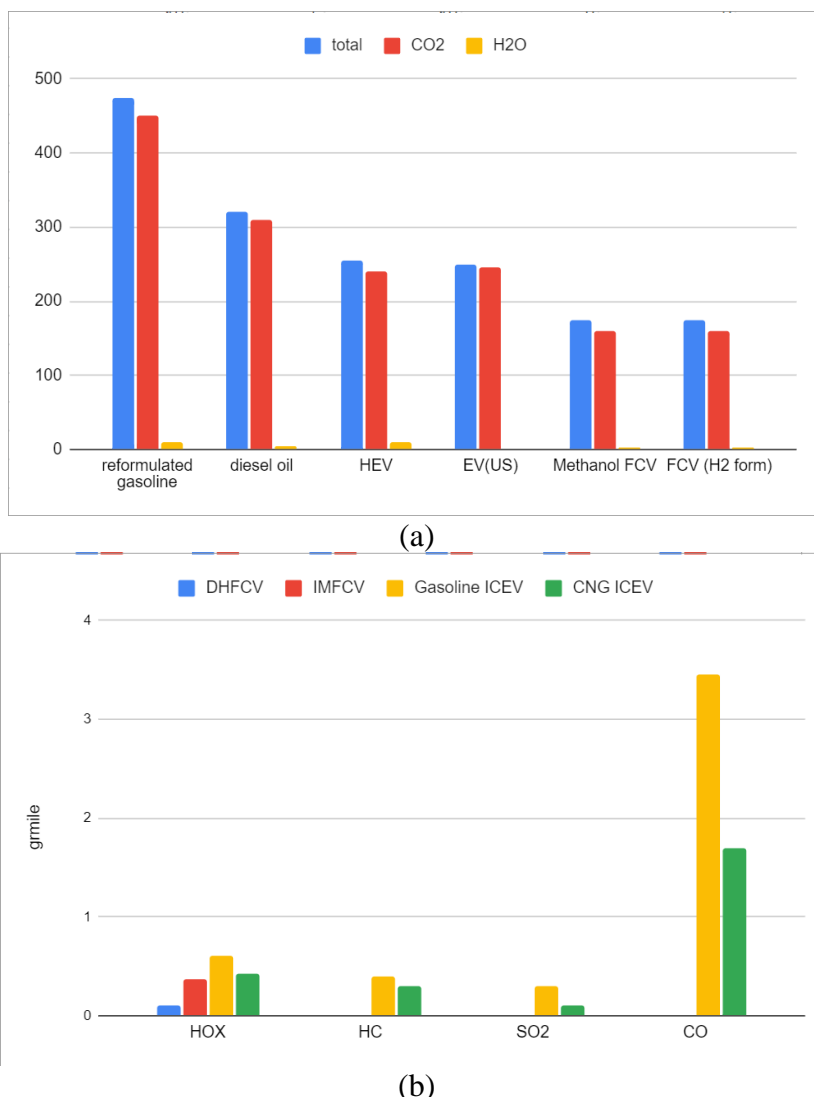

Figure 9 Comparison chart of pollutants discharged [2]

All-electric vehicles are zero-emission vehicles because they produce no direct exhaust or tailpipe emissions.

Traditional fuel vehicles produce a lot of pollution and greenhouse gases every year. A typical passenger vehicle emits about 4.6 metric tons of carbon dioxide per year. Transport accounts for a fifth of global carbon dioxide emissions each year, and three-quarters of that come from traditional fuel vehicles. However, electric vehicles (EVs) and Plug-in hybrid electric vehicles (PHEVs) will not produce any pollution during running. But when using the ICE, PHEVs also produce tailpipe emissions, their direct emissions are typically lower than those of comparable conventional vehicles. But that doesn't mean all electric cars are 100% environmentally friendly. Electric cars are pollution-free on the road, but they can be powered in many ways. For example, thermal power generation, which is the most common and simplest power generation method at present, requires the use of coal mines and a large amount of water, and the combustion of combustible materials will produce a large amount of waste gas, which will also cause great pollution to the environment. To sum up, electric vehicles can achieve 100% zero emission, but the source of electricity cannot be completely zero pollution. [2]

3.4. Top pros and cons of electric cars and social opinion about electric cars

As an emerging vehicle in recent years, consumers have also taken a keen interest in electric vehicles. Governments are also encouraging people to buy new energy vehicles. Compared with

traditional fuel vehicles, electrical vehicles have the following advantages: Energy efficient, better for the environment, lower cost of use and maintenance is less frequent and less expensive. But at the same time, some disadvantages of electric vehicles should not be ignored: Can't travel as far as gas cars, takes longer to fuel, sometimes it's hard to find a charging station and right now there are not too many options for consumers. We believe that with the future development, these shortcomings will be overcome. [7]

3.5. Hybrid Power Transmission Configuration Classification

3.6.1 Parallel hybrid system:

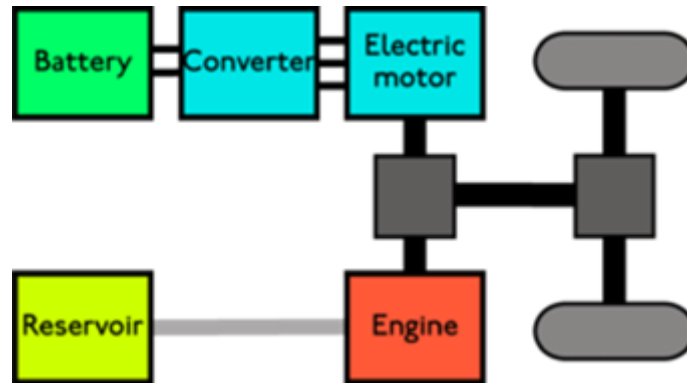

Figure 11. Parallel hybrid system [16]

Picture 13 shows the structure and power connection of the Parallel hybrid system. In the picture, we find that the internal combustion engine and electric motor of the Parallel hybrid system are separate and independent of each other. [14] This means that under this system, the electric motor and internal combustion engine can drive the vehicle independently. The power output by the internal combustion engine and the electric motor are transmitted through the mechanical transmission system to push the wheels. Both are controlled by a computer at the same time to achieve coordination. This parallel hybrid power system cannot be driven by electricity alone. Because the battery capacity of the parallel hybrid system is small, the main space and structure are still composed of traditional internal combustion engines.[12] The internal combustion engine is the main power source, the electric motor is the auxiliary power system, and the two are coupled through the mechanical transmission system. When the vehicle starts at a standstill or travels at a low speed, the driving mode of the vehicle will change to a pure electric mode, and the internal combustion engine will stop operating. When the vehicle is above the set speed or operating at high speed, the pure electric mode will be turned off, and the driving mode will be changed to pure internal combustion engine drive.

The parallel hybrid power system perfectly solves the problems of high fuel consumption and high emissions caused by traditional internal combustion engines at low speeds, and also solves the problem of high-power consumption caused by pure electric vehicles at high speeds. In the parallel hybrid system, there is no generator for battery charging, so there are two main sources of charging: One is to use a regenerative braking system to convert kinetic energy into electrical energy when the vehicle decelerates and stops. The second is to drive the electric motor to rotate and generate electricity when the internal combustion engine has surplus power. This system retains the fuel-saving characteristics of the internal combustion engine at high speeds, which is beneficial for driving on highways.

3.6.2 Series hybrid system:

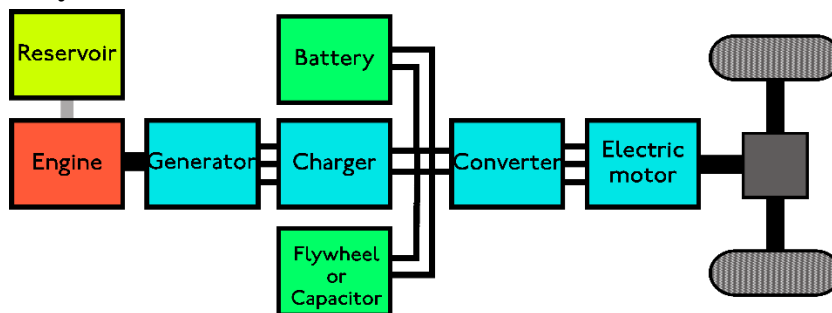

Figure 12. Series hybrid system [16]

Picture 14 shows the connection mode and structure of the Series hybrid system. In the picture, we find that the electric motor is directly driving the vehicle, and the internal combustion engine is connected to the generator and battery. The only driving wheel in a car is the electric motor, and electrical energy is used to charge the battery and power the electric motor. In this system, the internal combustion engine is only responsible for stable operation and power generation, continuously charging the battery. Therefore, the configuration of the internal combustion engine in the series hybrid system is very flexible. There is no need to choose a large-displacement multi-cylinder internal combustion engine in consideration of vehicle weight and performance, but only a small-displacement internal combustion engine that runs stably, which greatly solves the problem of high emissions and high pollution from traditional internal combustion engines, easier to control pollution and improve efficiency. And due to the existence of the internal combustion engine, the problem of insufficient battery life of pure electric vehicles in the extremely cold winter temperature is greatly solved. The heat generated by the internal combustion engine can be transferred to the battery, keeping the battery at the best operating temperature in extremely cold environments, extending the mileage and battery life. Because of the push and connection of the electric motor, these benefits are the same as those of a pure electric car. Simplifies the mechanical structure, eliminates the need for gearboxes, and brings high transmission efficiency. The series hybrid system is suitable for use in urban areas, but the situation on the highway is not very beneficial.

3.6.3 Series-Parallel hybrid system

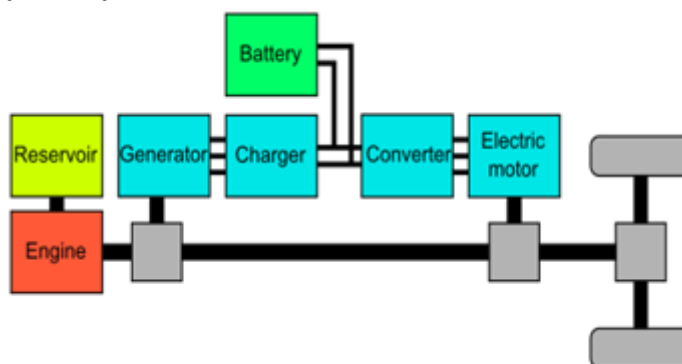

Figure 13. Series-Parallel hybrid system [16]

Picture 15 shows the structure and drive mode of the Series-Parallel hybrid system. In this system, we find that the internal combustion engine and electric motor are connected to the drive shaft at the same time, which means that this system is similar to a parallel hybrid, but the internal combustion engine is also connected to a generator. Therefore, this system has both parallel hybrid and series hybrid drive and operation modes. The driver can choose pure electric driving, internal combustion engine driving and hybrid mode. This has all the advantages of parallel hybrid power, series hybrid power, pure electric power, and internal combustion engine at the same time. The internal combustion engine will push the generator to charge the battery or directly power the electric motor when needed. When the car is starting or at low speed, the efficiency of the internal combustion engine is low, so it

will rely on the better efficiency of the electric motor to drive it. When the car is at a high speed, relying on the internal combustion engine will solve the high consumption caused by pure electricity. For example, when the car is accelerating or climbing, the internal combustion engine and the electric motor will start at the same time to bring more horsepower.[15] The system also retains the fuel-saving characteristics of the internal combustion engine at high speeds and the high efficiency of the electric motor at low speeds, which is conducive to highway driving and urban driving.

3.6.4 Example



Figure 14. Hybrid double-decker bus in London [13]

The world's first hybrid double-decker bus was put into service in London in February 2007. There are 106 gasoline-electric hybrid buses in London now. Compared with all-electric buses, hybrid buses are more mature in technology and do not require additional charging facilities. In addition, in areas where coal-fired power generation is used, their carbon emissions are lower than pure electric buses. The experience of double-decker buses in the UK can reduce fuel consumption by 40% [9][10]

3.6.5 Carbon emission

Table 1. Vehicle Whole Life Carbon Emissions Analysis

	Estimated life cycle emissions (Tones CO2e)	Proportion of Emissions in production	Estimated emissions in production (Tones CO2e)
Standard gasoline vehicle	24	23%	5.6
Hybrid vehicle	21	31%	6.5
Plug-in hybrid vehicle	19	35%	6.7
Battery-electric vehicle	19	46%	8.8

Based upon a 2015 vehicle in use for 150k KM using 10% ethanol blend and 500g/kWh grid electricity. [11]

Although low fuel consumption does not mean that the carbon emissions of the total life cycle are low, because the carbon dioxide produced during the manufacturing process of hybrid vehicles may be higher than that of ordinary cars. But even considering the carbon dioxide emissions from the production process, the total carbon emissions of hybrid vehicles are still lower than those of pure internal combustion engines.

4. Conclusion

In conclusion, electric vehicles are the leading role in the future because of high efficiency and environmentally friendly features, though scientists need to overcome low capacity and low efficiency on the highway. Contemporarily, hybrid vehicles are famous around the world, but they still rely on petrol so they are just a transition production before the technology of electric vehicles is greatly improved. Traditional engines will also be replaced because of the characteristics of heat, which is the energy of “low quality” due to the second law of thermodynamics. But for some of them

like diesel engines, it is still useful and efficient to oversize vehicles so to bus or motor tractor, diesel engine will still be their first choice.

Reference

- [1] A Program of the U.S Department of Energy. <https://www.energy.gov/sites/prod/files/2014/04/f15/10097517.pdf>
- [2] Emissions from hybrid and plug-in electric vehicles. (n.d.). Retrieved from https://afdc.energy.gov/vehicles/electric_emissions.html
- [3] Canada, N. (2020, February 20). Government of Canada. Retrieved September 01, 2021, from <https://www.nrcan.gc.ca/energy-efficiency/energy-efficiency-products/product-information/industrialcommercial-equipment/electric-motors/14788>
- [4] Thermal engines versus electric motors. (2019, August 13). Retrieved September 01, 2021, from <https://www.wingsmagazine.com/thermal-engines-versus-electric-motors/>
<https://ieeexplore.ieee.org/document/4813059>
- [5] Fernando J.T.E. Ferreira; Anibal T. de Almeida. (2017) Reducing Energy Costs in Electric-Motor-Driven Systems: Savings Through Output Power Reduction and Energy Regeneration. IEEE. **Page(s):** 84 – 97. <https://ieeexplore.ieee.org/abstract/document/8023737>
- [6] UNIDO, (2011), Energy efficiency in electric motor systems: Technology, saving potentials and policy options for developing countries. <https://open.unido.org/api/documents/4818324/download/Energy>
- [7] Lixin Situ, (2009), Electric Vehicle development: The past, present & future. Hong Kong, China. <https://ieeexplore.ieee.org/abstract/document/5228601>
- [8] Fundamentals of Engineering Thermodynamics, 8th Edition by Michael J. Moran, Howard N. Shapiro, Daisie D. Boettner, Margaret B. Bailey (z-lib.org11), 513
- [9] Autoblog is now a part of Verizon Media. (2010, May 18). Autoblog. <https://www.autoblog.com/2010/05/18/video-london-mayor-approves-new-hybrid-double-decker-bus-design/>
- [10] Autoblog is now a part of Verizon Media. (2007, March 17). Autoblog. <https://www.autoblog.com/2007/03/17/first-hybrid-double-decker-bus-hits-the-road-in-london/>
- [11] Ricardo study finds electric and hybrid cars have a higher carbon footprint during production than conventional vehicles, but still offer a lower footprint over the full life cycle. (n.d.). Green Car Congress. Retrieved September 1, 2021, from <https://www.greencarcongress.com/2011/06/lowcvp-20110608.html>
- [12] What is a Hybrid Vehicle? - An introduction to hybrid cars and how they are defined, with examples of different hybrid technologies. (n.d.). What Is What. Retrieved September 1, 2021, from https://what-is-what.com/what_is/hybrid_vehicle.html
- [13] A. (2008, November 4). Wright Gemini 2 launched at Euro Bus Expo. AllAboutBuses. <https://allaboutbuses.wordpress.com/2008/11/04/wright-gemini-2-launched-at-euro-bus-expo/>
- [14] Hybrid Center : How Hybrid Cars work : under the hood 2. (2010, January 11). Archive. <https://web.archive.org/web/20100111032823/http://www.hybridcenter.org/hybrid-center-how-hybrid-cars-work-under-the-hood-2.html>
- [15] Gable, S. C. (2013, March 29). What is a Full Hybrid? About.Com Hybrid Cars & Alt Fuels. <https://web.archive.org/web/20130329143024/http://alternativefuels.about.com/od/glossary/g/fullhybrid.htm>
- [16] Wikipedia contributors. (2021, August 10). United Nations Framework Convention on Climate Change. Wikipedia. https://en.wikipedia.org/wiki/United_Nations_Framework_Convention_on_Climate_Change