

The design the Simulation of Smart Pet Home

Kejun Liu^{1, †, *}, Haoran Wen^{2, †}, Zhaojun Wu^{2, †}

¹Ontario Academy of International Education (OAIE), Nanjing, L3R4L9, China

²Guangdong Experimental High School, Guangzhou, 510375, China

*Corresponding author's e-mail: 100856@yzpc.edu.cn

Abstract. More and more families have their pets and pets become an essential part of our daily life. This article is to solve the problems of temperature and humidity control, automatic weighing, and automatic opening of cage door. The simulation of the design demonstrate that the new design is more accurate and automatic including the DHT11, AT89S52, DT711, LCD1602. All these hardware consist the whole system, especially AT89S52 is the most paramount part of the design which is the microprocessor while the LCD screen as the output device. The DHT11 and DT711 works as input device which would collect the data of temperature and humidity, also the weight. If the sensors sample the abnormal data and send to the microprocessor, then the microprocessor would send the order of the alarm and the adjustment module which contain the fan, heater, humidifier.

Keywords: temperature control, humidity control, automatic weighing, opening and closing option.

1. Introduction

In contemporary society, more and more people prefer to feed a pet especially bachelordom in super city such as New York, Beijing, or London. To them, pets is not only an animal but also a family member who accompany the lonely youth. Our design is to solve the urgent problem which annoy the youngsters by means of the pets accept no care and they even destroy the furniture when their hosts to go to work. At present, most hosts have to spend a lot of money to drive their pet to the specialised kindergarten which only provide services for pets [1]. In contrast, this method is cost-ineffective and troublesome. Due to this, the research group generated microprocessor technology, automatic control technology, wireless communication technology, sensor technology, adjustment technology, power supply technology, control technology, etc into a smart pet home application. As the core of microprocessor, the live real data is monitored at any time and the data is displayed on the LCD. The system would alarm and send the message to the administrator when it detected some abnormal data, then switch on some devices to adjust the value into the standard range.

2. Ambient temperature and humidity control module

To control the temperature and humidity is within the given range. If the temperature or humidity out of the given range, the edge would take the corresponding actions. To ensure rabbit is comfortable, the choice and layout of the temperature and humidity sensor of the block diagram need to consider the measurement to be measured temperature and humidity data intervals. According to literature, the interval of temperature is between 15 °C and 25 °C exclusively, the interval relative humidity is between 55% and 65% exclusively. LCD would display the present humidity and temperature. In addition, other function includes taking actions to switch on some devices to keep the temperature and humidity in the given range. The LCD screen display the present temperature and humidity. The main control module was shown in figure 1.

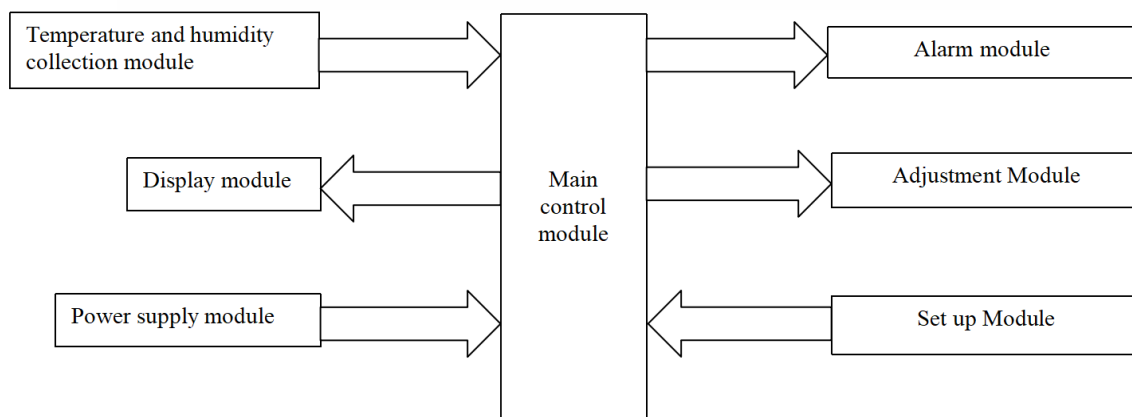

Figure 1. Main control module

2.1. Hardware circuit design

2.1.1 Main Control Module and Power Supply Module

The main control module adopts STC89C52 microprocessor. STC89C52 is a very widely used high-performance CMOS 8-bit microprocessor, which have 4K bytes of system programmable flash memory with actual operating frequencies up to 35MHz. The microprocessor has 27 general-purpose I/O ports and a 10-bit precision ADC functions, 2×16 -bit timers, on a basis that fully satisfying the functional requirements, with a high price-performance ratio. As shown, the smallest system mainly contains a single-chip microprocessor, power supply circuits, and reset circuits and oscillation circuits [2].

The power module provides a stable voltage for system operation. The crystal oscillator circuit consists of crystal oscillators X1, C2 and C3 and C4 The combined resonant circuit is composed to provide a reference clock signal for the microprocessor. Both C2 and C3 are 30pF. And the X1 is 11.0592MHz.

The reset circuit uses power-on the way of combination automatic reset and manual key reset. For power-on auto-reset, R and C should be reasonably chosen. The value keeps the high level high for at least two machine cycles. Generally, the URST is greater than 3V can make the microprocessor reliable reset, the design of the reset circuit selected R3 is 100Ω and C1 is 1.

2.1.2 Temperature and humidity collection module

As mentioned before, the temperature is $15^{\circ}\text{C} \sim 25^{\circ}\text{C}$ and the humidity is 55%~65% [3]. And the range of DHT11 temperature measurement is from 0°C to 50°C , and the humidity is 5%RH to 95%RH, which can satisfy the temperature and humidity which are suitable for rabbits. Considering the distance of DHT11 transferring signal which is 20m, it is much longer than the longest diagonal of the edge [4]. The circuit diagram of the DHT11 is shown in Figure 4, where the power pins VDD is connected to a supply, and pin DATA is dangling, GND is the ground terminal.

2.1.3 Display Module

The liquid crystal display module used in this system is LCD1602, which is a kind of dot matrix liquid crystal [5]. The module interface is simple, easy to use, and functional. It is low-energy consumption and the price is cheap. The LCD can display 16×2 characters, this design displays all the data by automatically switching screens.

In this design, the number of LCD1602 LCD monitors is connected to the interface P0.0~P2.7 of the microprocessor STC89C51.

2.1.4 Alarm Module

The system alarm module is implemented via a buzzer to achieve sound alarm. After the administrator sets the upper and lower limits of temperature and humidity, the temperature and

humidity sensor collection module in the system performs real-time sampling and sets the values [6]. After comparison, if it is not within the preset range, the buzzer alarm is driven.

2.2. Adjustment design

During the period, the program can judge the environment quickly. If the temperature is below the 15°C, the electromagnetic relay of it would be switched on, the heater would be turned on. If DHT11 detected the temperature is over 25°C, the electromagnetic relay of it would be switched on, the fan motor for cooling would be switched on. If the present humidity is over 65%, the electromagnetic relay of it would be switched on, the fan motor for drying would be turned on. If the present humidity is below 55%, the electromagnetic relay of it would be switched on, the humidifier would be turned on. The flow chart was shown in figure 2.

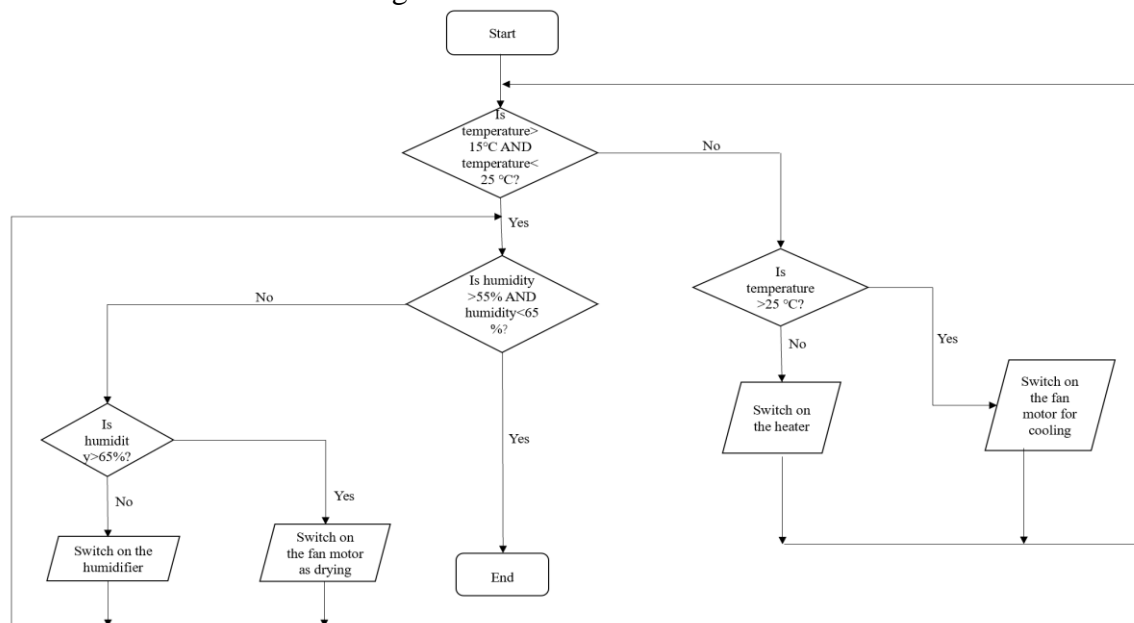

Figure 2. Flow chart

2.3. Test results

After the system software is debugged in Keil, it cooperates with Proteus imitation software to achieve hardware and software joint debugging and simulation. The simulated circuit is shown in Figure.9. In the simulation experiment, it is impossible to obtain the temperature and humidity of the real environment values, temperature and humidity values change with direct setting of the temperature and humidity of the two DHT11 to simulate. First step is to set by setting the buttons and adding and subtracting buttons to set the upper and lower limits of temperature and humidity, and then set the temperature and humidity of the two DHT11. The value is a variety of possible scenarios. The response to the buzzer matches the present state, and the LCD is also available to display.

The upper limit of temperature is 25°C, while the lower limit of temperature is 15°C In contrast, the upper limit of humidity is 65%, while the lower limit of temperature is 55% in Figure 3.

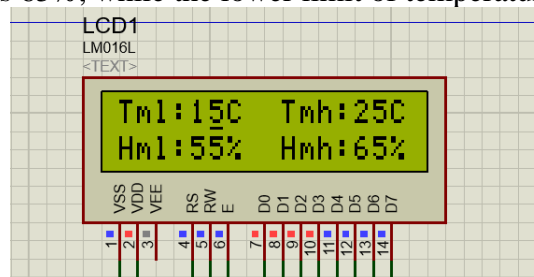

Figure 3. Set up value

If only temperature over the highest level which means DHT11 detected the temperature is more than 25°C, the electromagnetic relay of it would be switched on, the fan motor for cooling would be switched on. If the only temperature is below the 15°C, the electromagnetic relay of it would be switched on, the heater would be turned on. If the present humidity is below 65%, the electromagnetic relay of it would be switched on, the humidifier would be turned. If the present humidity is below 55%, the electromagnetic relay of it would be switched on, the humidifier would be turned on.

3. Automatic weighing design

A weighing design is placed in the smart pet house. To be more precise, it placed in the pet's rest area, that is because a pet will spend some time staying still in the area, which means we can weigh it more easily. The system is mainly composed of chip and SCM. The Basic requirement of that is Weight range: 0kg~10kg; Measurement error: 0.1kg; LCD display: the pet's weight and the time at weighting; Other function: weight gain reminder and weight loss reminder

3.1. Hardware circuit design

The system includes: clock circuit, weighing module and data acquisition module. Weighing module includes: power supply, A/D conversion part, sensor, displace screen and alarm system.

3.1.1 The weighing sensor

The pressure sensor is the core of the automatic electronic scale. The resistance strain sensor is my final selection. Its component includes: resistance wire, overburden and strain gauge. Its principle is to use the strain effect of resistance. The resistance strain gauge can convert the mechanical strain signal into $\Delta R/R$ [7]. Due to the fact that this kind of change is very small, which is inconvenient to handle and difficult to measure directly and accurately. Therefore, the change of $\Delta R/R$ needs to use the strain gauge of the conversion circuit to convert the changes in voltage or current. Its conversion circuit is usually a measuring bridge. The bridge for strain gauge measurement needs to be balanced before measurement, so the output voltage of the bridge during measurement is only related to the resistance change caused by the strain induced by the strain gauge. As for the strain sensor, it has many advantages: it has less error, its error is usually under 1%. The size of it is small and it is very light. It has a large measure range, elastic deformation can be measure to plastic deformation (1%~2%) and up to 20%. The measurement can easily transmit, record and manage, besides the above, its price is low, so it can be scale used.

3.1.2 HX711 Analog to digital conversion circuit

HX711 is a high-precision 24-bit A/D converter which is usually used in weighing device. It can complete A/D conversion and the processing of Information. Compare to other chips of similar type, it also integrates the peripheral circuits such as stable power supply and on-chip clock oscillator etc. It has not only high integration, quickly response, but also has a better anti-interference. The use of it, reduce the cost, improve the performance and reliability. What's more, the input selector switch has two selections channel A and B. The power supply of voltage stabilizing circuit inside the chip (2.6V~5.5V) can supply power into both external A/D converter and sensor in the chip, so the system does not require additional power. In addition, when using the clock oscillator not any external devices are required. The initialization process of startup is simplified due to the automatic reset function of power on [8].

3.2. Software programming

Put the automatic weight sensor under the kennel. Program initialization. First set HX711. When the pet enters the pet nest, the automatic weighing sensor will detect the current weight of the pet and detect whether the pet has increased or lost weight. And there will be a corresponding weight display and weight reduction display. The data will be transmitted to the microcontroller.

After processing the data, the microcontroller sends the data to the pet owner's mobile phone and the display screen respectively, and the pet owner can analyze the pet's health condition according to the data. Software programming test is just as the Figure 4.

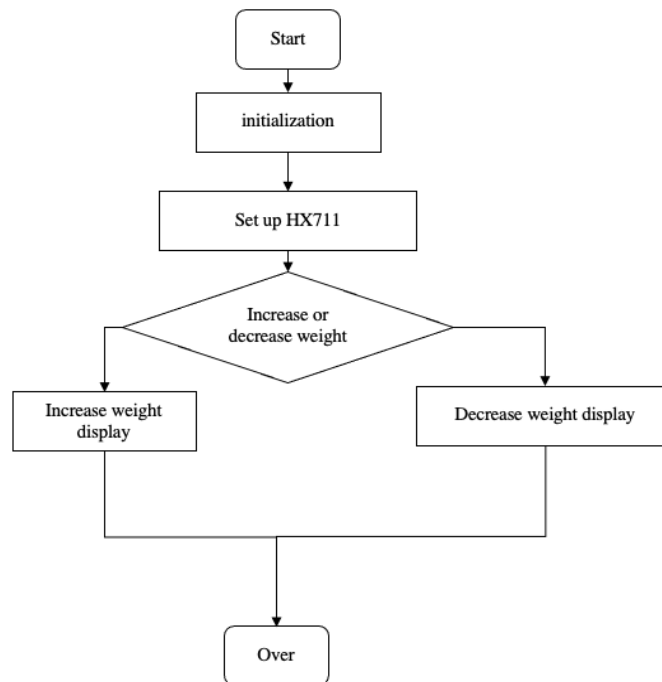

Figure 4. Software programming test

3.3. System test

In order to have a clearer understanding of the circuit structure, the hardware circuit simulation and debugging are used to ensure the correctness of the relevant hardware connection and code. And the test circuit was shown in figure 5.

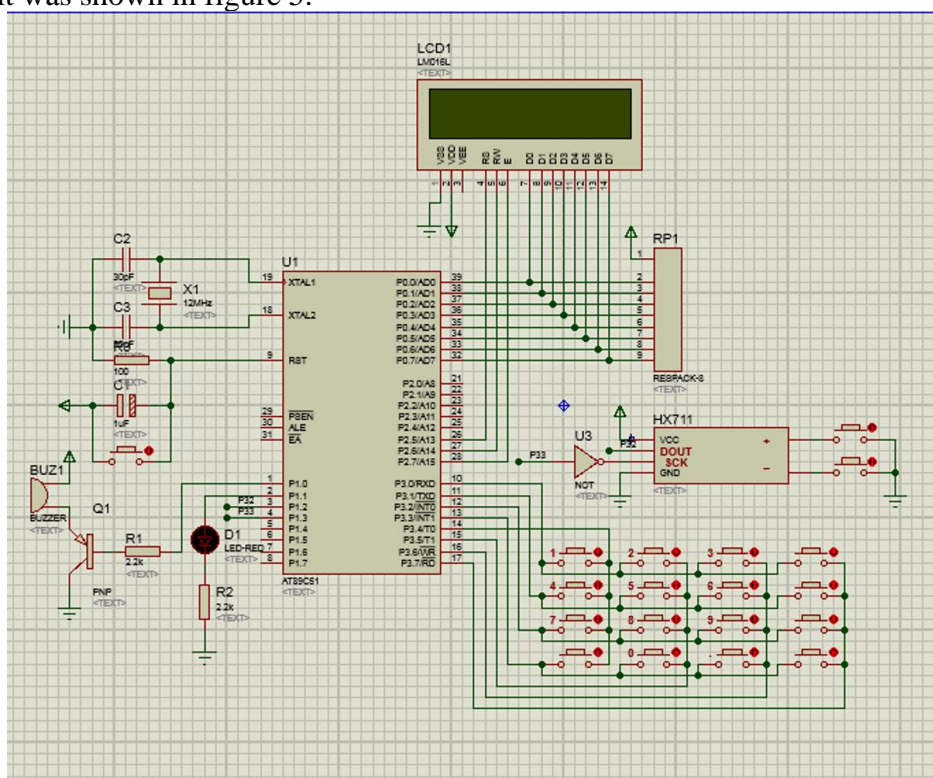

Figure 5. Hardware test

After connecting the corresponding circuit diagram, the program is written into the microcontroller program. The main failure is caused by inconsistent code definition ports.

The test results shows that the display screen LCD1602 can show the number of the pet's weight, time, and date. In addition, the app on the phone can not only record the weight and time, but also it can show the change of pet's weight.

For a pet weighing 5kg a experimental simulation is performed, the detail was shown in table 1.

Table 1. Experimental simulation of a pet weighing

Date	Weight/kg	Change of weight/kg
5.12	5	0
5.17	5.5	+0.5
5.23	5.6	+0.1
6.1	5,4	-0.2
6.7	5,7	+0.3
6.13	6	+0.3

As shown in the Table 1, the data of weight and the variation can be showed on the app of pet owner's mobile phone.

4. Automatic opening and closing design

Pyroelectric infrared sensor can receive infrared rays of specific wavelength emitted by human body and animal radiation, and convert them into low-frequency electrical signals related to biological distance, movement speed and direction. Because of its low price, and convenient to use. In real life, it is often used in some automation equipment or alarm devices, such as hair dryer, automatic faucet in shopping malls or alarm devices in banks and many other products [9]. Pyroelectric crystals have been widely used in environmental pollution monitoring and non-contact temperature detection. It can be used as an ideal detector for infrared laser. It aims to be widely used in various automation control devices.

Pyroelectric effect refers to the phenomenon that the surface of a crystal is charged due to the change of temperature, which is similar to the piezoelectric effect. Pyroelectric sensors are extremely sensitive to temperature. It the composition of piezoelectric crystal elements or ceramic oxide. Electrodes are made on the two surfaces of the elements. the pyroelectric effect will produce a charge ΔQ on the two electrodes which means a weak voltage ΔV will be generated. When the temperature changes ΔT within the range monitored by the sensor, will be generated between the two electrodes. There is a field effect tube in the sensor for impedance transformation due to high production. The charge ΔQ will be combined with ions in the air and disappear which means it has no production as the ambient temperature is stable and constant, $\Delta T = 0$. As the Animal body enters the detection area, the difference between the environment temperature and the Animal body temperature, ΔT is created. The sensor will not have output and temperature will not change if the human does not move after entering the detection area. This sensor can detect motion sensing in humans or animals.

4.1. Hardware circuit design

4.1.1 Stepper motor

Opening and closing circuit will use stepper motor and stepper motor drive module to achieve Door control device.

Stepper motor is an open-loop controller element that converts electrical pulse signal into line or angular displacement. When it is not overloaded, the pulse signal and frequency number determine the stop and speed of the motor position [10]. The motor is not affected by load changes. The motor will rotate a step Angle when a pulse signal is added to the motor. The application of stepper motor

is quite wide. However, it cannot work under normal condition. It must be controlled by a double ring pulse signal and a power drive circuit before it starts to work.

4.1.2 Drive control system

In order to use and control stepper motor, it must compose power amplification, signal distribution, etc. The drive control system was shown in figure 6.



Figure 6. Drive control system

Produce pulse signal. The pulse signal is produced by MCU. Its duty ratio is 0.3-0.5. The velocity of pulse signal motor is proportional to the duty ratio.

Signal distribution. The Stepping motor is mainly based on two-phase and four-phase motors. Two-phase motors mainly work in two types: single-four-beat and double-eight-beat.

Power amplification. Its torque is controlled by its dynamic average current as the speed of the stepping motor is constant. The average current is proportional to the motor torque. In order to obtain a large average current, the drive system must overcome the back EMF of the motor. Therefore, it is the most important part of the drive system.

Micro-stepping driver. If the step angle of the stepper motor cannot satisfy the work, micro-stepping driver can be used to drive stepper motors. The principle of the subdivision driver is to control the operation of the stepper motor by changing the size of the adjacent (q, Q) currents to change the included angle of the synthetic magnetic field.

4.1.3 Infrared detection circuit

The core element of the infrared detection circuit is the pyroelectric infrared sensor. Generally, the pyroelectric infrared sensor has low receiving sensitivity and the detection distance is only about 2m. Therefore, when the pet close to the automatic door, it will pick up by the pyroelectric infrared sensor and convert it into a signal. After the detection of amplification circuit internal amplification and other processing output to the MCU.

4.2. Software programming

First, initialize. Set the infrared sensor. When a pet stands in front of the nest, an infrared sensor on top of the nest detects that the cat or dog is in front. The steering gear will rotate, turn forward, pause for ten seconds so the pet can enter, then reverse, and the door will close. But not if the door was opened by mistake. The software programming was shown in figure 7.

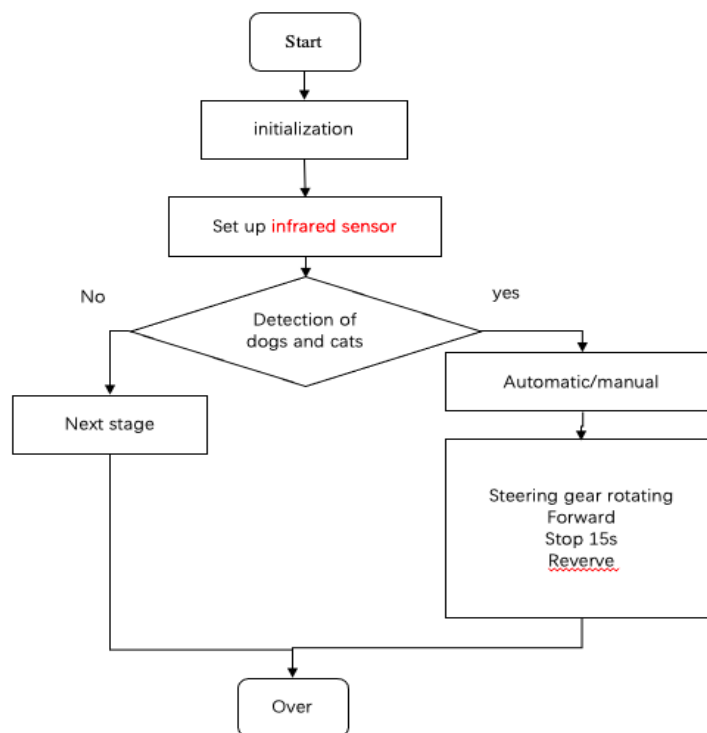

Figure 7. Software programming

5. Conclusion

Nowadays, pets are friends of many urban residents and have many benefits to owner’s mental health, which make it popular in urban. The design of smart pet house is based on ST89S51, a single chip microcomputer, which has the function of temperature and humidity adjustment, automatic door and automatic weighing. We use single chip to control DHT11 temperature and humidity sensor, and the temperature and humidity information is displayed on the 1602 display screen, and the fan, heater and humidifier are controlled to change temperature and humidity. The signal measured by the infrared sensor can be fed back to the main control chip to control the steering gear to open and close the door. The hx711 pressure sensor monitors the pet's weight and displays it on the 1602 display screen. In order to have a clearer understanding of the circuit structure, the hardware circuit simulation and debugging are used to ensure the correctness of the relevant hardware connection and code. We use Proteus to test the hardware. This product not only makes pets more comfortable, but also shares the basic life concerns of owners when caring for pets and saves a lot of time for the owner. In the future, this design can be added with Bluetooth module for remote monitoring or integrated into smart home in order to make the future life more intelligent. The research and design of this product have better integrated electronic information knowledge and computer knowledge, expanded our knowledge, and further trained us to learn electronics and computers.

References

- [1] Nurhayata, I. G., Sutaya, I. W., & Ariawan, K. U. (2021). The development of prepaid water meters based on AT89S52 Microcontroller. *Journal of Physics: Conference Series*, 1810(1), 012004.
- [2] Jai Ganesh, R., Shanmugam, D., Munusamy, S., & Karthikeyan, T. (2021). Experimental study on footstep power generation system using piezoelectric sensor. *Materials Today: Proceedings*, 45, 1633–1637.
- [3] Saputro, A. D., & Yantidewi, M. (2021). Analysis of Air Temperature and Humidity in Kedungalar Against BMKG Data Based on DHT11 Sensor. *Journal of Physics: Conference Series*, 1805(1), 012045.

- [4] Zhu, Y., & Fang, Y. (2021). Greenhouse Intelligent Monitoring System Based on MCU. *Journal of Physics: Conference Series*, 1982(1), 012072.
- [5] Su, Q., Liu, Y., & Wu, H. (2021). Smart Pet Feeding Device Based on Single Chip Microcomputer. *Journal of Physics: Conference Series*, 1885(5), 052032.
- [6] Aravind Kumar, M., Madhu Shankar, K., Malleeswaran, V., & Dharani, K. (2021). Development of PIC Based CO₂ Monitoring System Device. *Journal of Physics: Conference Series*, 1937(1), 012026.
- [7] Hastawan, A. F., Haryono, S., Utomo, A. B., Hangga, A., Setiyawan, A., Septiana, R., Hafidz, C. M., & Triantino, S. B. (2021). Comparison of testing load cell sensor data sampling method based on the variation of time delay. *IOP Conference Series: Earth and Environmental Science*, 700(1), 012018.
- [8] Weng, Y., Zhao, Y., & Ni, X. (2021). Design of Testing Device for Mechanical Property Testing System of Tai Lake Shield. *Journal of Physics: Conference Series*, 1865(3), 032086.
- [9] Amole, A., Oyediran, M. O., Olusanya, O. O., Elegbede, W. A., Olusesi, A. T., & Adeleye, A. O. (2020, October 28). Design and implementation of a prototype active infrared sensor controlled automatic sliding door for mitigation of coronavirus disease 2019 (COVID-19). *Journal of Electrical, Control and Technological Research*, 2, 1–17.
- [10] Sharan, R. V., & Onwubolu, G. C. (2013). Simulating the Arm Movements of a Stepper Motor Controlled Pick-and-Place Robot Using the Stepper Motor Model. *International Journal of Advanced Science and Technology*, 60, 59–66.