

# Research Status and Prospect of Embedded System

Jiandi Wang\*

College of Automation (College of Artificial Intelligence), Hangzhou Dianzi University, Hangzhou, 310018, China

\* Corresponding Author Email: 20066126@hdu.edu.cn

**Abstract.** Embedded system is one of the key research topics nowadays. The engineers found that embedded system can be applied in many electronic engineering fields, such as daily household appliances, industrial control, etc. A complete embedded system includes all of the necessary components, such as an embedded processor, hardware structure, software system, and operating system. The central characteristics of embedded systems are the heterogeneity of their implementation technologies (digital hardware, software), the tightness of their nonfunctional requirements, and their complexity. Despite the fact that embedded systems have been widely used in modern society, there is still a lack of unified understanding of the classification of embedded processors. Through the understanding of the overall structure of embedded systems and the research of the application status of embedded systems, researchers or engineers can make wiser choices when designing embedded systems.

**Keywords:** Embedded system; Composition; Prospects; Application state.

## 1. Introduction

The rapid development of digital technology, with computers and software as the core, and the rapid popularization of Internet applications, have led to people's lives being more closely integrated with embedded systems [1-2]. An embedded system control many devices in common use today. These include: cell phones, digital cameras, MP3 players, personal computers, video game consoles, and industrial robots. An embedded system is a system that has computer hardware and software integrated into it. This integration provides the system with specific functionality. The computer hardware and software in an embedded system are designed to work together [3]. This design makes the system more reliable and efficient. These systems typically include of embedded microprocessors, auxiliary hardware, embedded operating systems, and application software for managing, controlling, and monitoring other devices. In terms of structure, it can be embedded in the application equipment or system in the form of box, single board, single chip or distributed nodes as the application changes [4]. Through the detailed description of the composition of the embedded system, people can understand the embedded system more clearly. At the same time, the prospect of embedded system use is proposed, which provides new ideas and references for users of embedded systems.

## 2. Hardware structure

The hardware component of an embedded system serves as the system's physical foundation and offers the software operating platform and communication (including an interface for human-computer interaction) [4]. The hardware of an embedded system is made up of three parts: the core processor, the peripheral circuit, and the peripheral device.

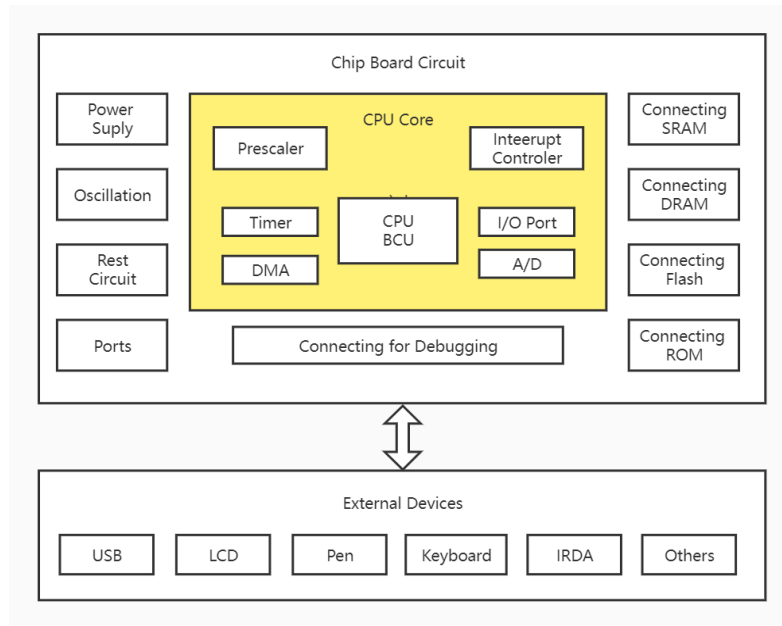

**Fig 1.** Embedded system hardware architecture.

## 2.1. Embedded processor

The various types of embedded processors are the core of the embedded system. The primary distinction between embedded processors and general-purpose processors is that embedded processors are created to work in systems that are particularly designed for specific user groups. It consolidates many functions of a general-purpose CPU onto one chip, making embedded systems more compact and efficient [3]. Generally, all the embedded processors can be divided into four main types, EMPU, MCU, EDSP and SoC.

### 2.1.1. Embedded microprocessor unit (EMPU)

The EMPU has arisen from the CPU in the general-purpose computer [5]. By using the CPU as a microprocessor, the EMPU can assemble it on a special circuit board to form an embedded system. This system would only retain functions related to embed applications, and as a result, greatly reduce the system volume and power consumption. While embedded microprocessors have similar functions to standard microprocessors, they have made various enhancements in terms of operating temperature, anti-electromagnetic interference, and reliability. And these are to meet the special requirement of embedded applications.

Embedded microprocessors have made various enhancements in terms of operating temperature, anti-electromagnetic interference, and reliability. These enhancements allow embedded microprocessors to better withstand harsh environments and operate reliably in them. The improved operating temperature range and anti-interference capabilities of embedded microprocessors make them well-suited for use in a variety of applications. The reliability of embedded microprocessors makes them an attractive option for use in critical applications [6-7].

### 2.1.2. Microcontroller unit (MCU)

Single-chip microcomputers are widely used in embedded devices and are one of the most representative embedded systems. Microcontroller is to integrate various functional components, including central processing unit, RAM, ROM, Input/Output, timer/counter and interrupt system, into a chip to form a complete microcomputer [1]. Different models of the same series of microcomputers are necessary to meet the requirements of various applications. This is because different applications have different requirements. For example, some applications require more processing power than others. Some applications require more memory than others. And some applications require more storage than others. These models have different configurations of memory and peripherals. At the same time, this also maximizes requirements and reduces costs.

### 2.1.3. Embedded digital signal processor (EDSP)

DSP is a microprocessor that is specifically designed to process digital signals in real-time. The design of the system structure and instruction algorithm has been carefully considered to promote high compilation efficiency and instruction execution speed. The Harvard structure, which separates program and data, is used inside the chip. It has specific DSP instructions, makes extensive use of pipeline operation, and features a unique hardware multiplier that may be used to quickly create a variety of digital signal processing algorithms. It has the outstanding advantages of fast computing speed, small size and low power consumption, and is very suitable for embedded real-time systems [2].

### 2.1.4. System on chip (SoC)

SOC (system on chip) is a new technology in ASIC (Application Specific Integrated Circuits) design methodology. It is the code module of the operating system that is directly embedded in the processor, with an embedded system as the core and IP reuse technology as the basis. It integrates software and hardware, realizing the seamless combination of software and hardware [3].

SOC can be divided into general purpose and special purpose. General series include Infineon's TriCore, Motorola's M-Core, some ARM series devices, and Neuron chips jointly developed by Echelon and Motorola [8]. The dedicated SOC is generally dedicated to a certain system or a certain type of system, and is unknown to ordinary users. A representative product is Philips' Smart XA, which makes the XA microcontroller core and CCU unit supporting more than 2048 bit complex RSA algorithm on a silicon chip, forming a special SOC that can load JAVA or C language, and can be used for public Internet, such as Internet security [9].

## 2.2. Peripheral circuit

The peripheral circuits in the hardware system of the embedded system, which include system memory, I/O ports, reset, and power supply, work together with the core to form a complete target embedded system.

## 2.3. Peripheral device

Various devices that the embedded system interacts with the real environment are referred to as external devices. At present, the commonly used embedded peripherals can be divided into storage devices, communication devices and display devices according to their functions [3].

Storage devices. Storage devices are mainly used to store all kinds of data, including static volatile memory (RAM, SRAM), dynamic memory (DRAM), and non-volatile memory (ROM, EPROM, EEPROM, and FLASH).

Communication devices. The vast majority of currently available communication tools, such as the RS232 interface (serial communication interface), SPI (serial peripheral interface), IrDA (infrared interface), I2C (field bus), USB (universal serial bus interface), Ethernet (Ethernet interface), etc., can be used directly in embedded systems.

Display devices. Due to the particularity of embedded applications, the peripheral display devices commonly used are cathode ray tubes (CRTs), liquid crystal displays (LCDs) and touch panels (TouchPanels).

## 3. Software system

The embedded system's software component manages how it functions. Its structure can be divided into four levels: device driver, operating system, application middleware and application system [4].

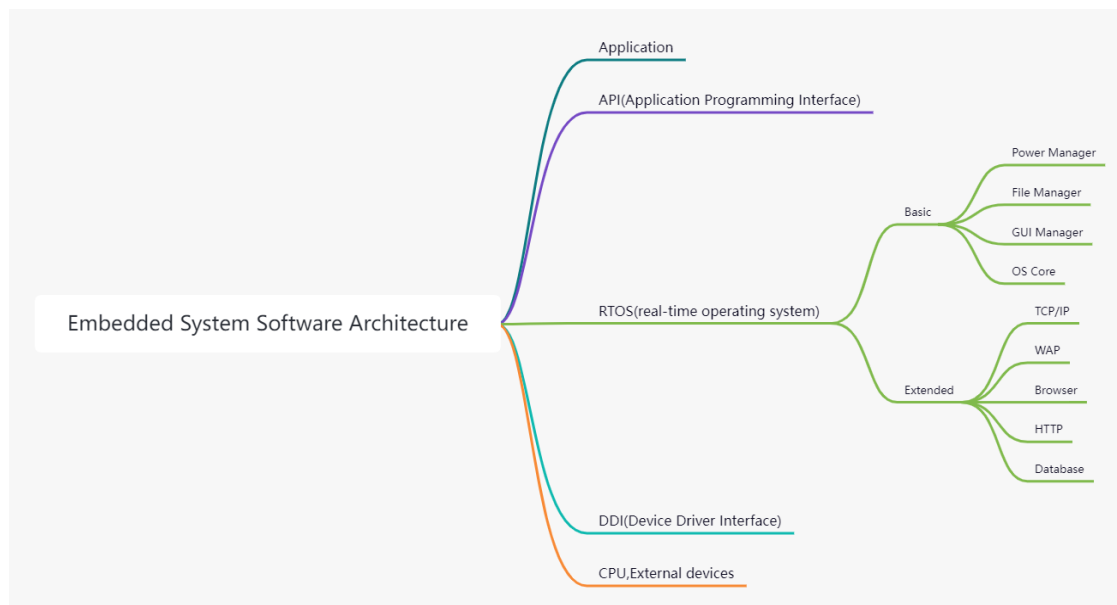

**Fig 2.** Embedded system software architecture.

### 3.1. Device driver

The writing of device driver is an important part of embedded system software design. The current driver development is usually based on hardware devices, looking for drivers and then migrating. If no driver is available, you will be forced to rewrite the device driver [5].

### 3.2. Operating system

The operating system used for embedded systems is referred to as embedded operating system (EOS). A type of commonly used system software called an embedded operating system often contains low-level drivers for the hardware, a system kernel, device driver interfaces, communication protocols, graphical user interfaces, standards browsers, etc. The task scheduling, control, and coordination of concurrent activities, as well as the allocation of all the embedded system's hardware and software resources, are all handled by the embedded operating system. The system in which it is located must be reflected in it, and it must be able to perform the necessary functions by loading and unloading certain modules. The embedded real-time operating system C/OS-II, embedded Linux, Windows Embedded, Windows CE, Palm OS, VxWorks, etc., as well as Android, iOS, etc., which are used in smartphones and tablets, are among the operating systems that are frequently utilized in the embedded area.

Each system has its unique advantages. Windows CE kernel, for example, is small and can be applied to industrial control and other fields as an embedded operating system [9]. Its advantages lie in portability, the choice of microprocessors, and non coercive power management functions [9]. Take another instance: The Palm OS of 3Com Company occupies a dominant position in the handheld computer and PDA market. It has an open operating system application program interface (API). Developers can develop their own applications as needed [9].

### 3.3. Application middleware

The middle layer, also known as the hardware abstract layer (HAL) or board support package (BSP), sits between the hardware layer and the software layer. This layer typically involves data input/output operations, initialization of relevant underlying hardware, and hardware device configuration [10].

The majority of the system's software modules that are directly tied to the hardware are really part of the BSP, a software layer that sits between the operating system and the underlying hardware. It

must finish two tasks in order to create a complete BSP: designing hardware-related device drivers and hardware initialization of embedded system and BSP functionalities.

### **3.4. Application system**

Embedded operating system is the soul of embedded application system, which undertakes important tasks such as task scheduling, task control, communication and synchronization between tasks, resource management, storage management, etc. But in the embedded application system, the embedded operating system cannot be called a complete operating system; The second and most important point is that a complete operating system is too complex and consumes too much system resources, which is almost unaffordable for embedded application systems with very valuable resources; Moreover, the design or selection of embedded operating system depends on the hardware environment of the target application system and the specific application [6].

Compared with other operating systems, embedded operating systems generally have only microkernel, no shell and graphical user interface, and even some other functions can be removed. Because of the requirement of its embeddedness, generally speaking, the operating system and application program are closely combined to make them run in the same space together [11]. The difference between the operating system and application program is not very clear. It can even be said that the operating system is a part of the application program. Because the memory capacity of embedded system is generally small, and the actual physical address is generally used, the storage management module is often very simple. In this way, the size of the kernel will be greatly reduced, making the kernel a real microkernel [6].

## **4. Application status**

With the rapid development of science and technology, embedded systems are also becoming more and more perfect, and their applications are gradually expanding, mainly in the Industrial field, Power system field, Traffic management and so on [12-13].

### **4.1. Industrial field**

Embedded system is widely used in industry, which greatly improves the work efficiency. For example, this can be clearly understood in industrial engineering control, digital machine tools, power systems, power grid security and petrochemical systems [14]. If industrial automation equipment wants to achieve considerable development, it cannot be separated from embedded systems. From the old low-end 8-bit single-chip microcomputer to the industrial control equipment with 32-bit and 64 bit processors as the core, it is enough for us to understand that the development of industrial equipment is based on the development of embedded systems. Especially in the numerical control technology, the embedded LINUX numerical control system uses Qtopia to complete the development of the human-machine interface of the system and uses C language to complete the development of the control level [14].

### **4.2. Industrial field**

Power system is a very important function for people's livelihood. With the gradual increase of current power demand, the number of substations is also increasing, and the distribution range is very wide, so it is difficult to manage. In this form, many substations adopt unattended management mode. By using embedded network servers, the labor intensity of substation managers can be effectively reduced, and the hidden trouble of substation can be found in time to improve the efficiency of fault handling [11].

### **4.3. Traffic management**

With the substantial increase of people's vehicle ownership, there are more and more vehicles in society, and the management of vehicle traffic becomes very difficult. However, embedded systems

are widely used in cars, ranging from GPS for general positioning, GSM for mobile positioning to vehicle flow control, information monitoring, vehicle navigation, and even transportation. It can be seen that embedded systems are widely used in traffic management [14].

## 5. Prospects

Today's embedded systems can be developed from the following four aspects: Systematization, Operation facilitation, Network interconnection and Functional diversity.

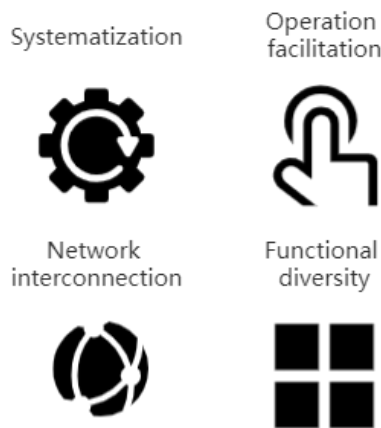

Fig 3. Prospects of embedded system.

### 5.1. Systematization

In the development and application of embedded systems, powerful development tools and operating systems are required to provide support. In the new era, Internet technology is developing rapidly, and online information is becoming more and more abundant. At the same time, various mobile device technologies are becoming more and more advanced, such as handheld computers, smart phones, etc. Therefore, the functions of embedded systems are becoming more and more abundant, and their structural forms are becoming more and more complex. In order to meet the actual needs of embedded system functions, for embedded processors, it is not only necessary to apply 32-bit and 64 bit RISC chips to improve their processing capacity, but also to apply programming technology and cross development tools to optimize the system program design scheme, shorten the program development cycle, and improve the quality of program design [11].

### 5.2. Systematization

With the embedded system going deep into people's life, people put forward higher requirements for the convenience of embedded system. With the development of embedded system, more and more people have to consider the troubles they will encounter in life, such as text input system, voice input system, etc. With the continuous development of science and technology, the use of embedded systems will become more and more convenient.

### 5.3. Network interconnection

With the development of the Internet, embedded systems also need to follow the trend to make the use of embedded systems more intelligent and convenient. On the hardware, the embedded system is constantly improving various forms of network interfaces, and on the software, the system kernel supports more network modules, moving towards the goal of accessing the Internet anytime and anywhere.

### 5.4. Functional diversity

With the development of science and technology, there is more and more networking and informatization, and people's demand for daily necessities is becoming increasingly intelligent, such

as mobile phones, household appliances and travel tools. This makes the internal structure of these devices more and more complex, so more and more functions are given to the chip. Therefore, designers need to integrate more powerful embedded system processors with more functions into the products, add functional interfaces, strengthen the processing ability of graphics and multimedia, and expand the type of bus [13]. At the same time, in terms of software design of the system, real-time multitask programming technology and cross development tool technology can be used to better control complex product functions, so that the application program design steps of the system can be simplified, so that the software development quality can be effectively guaranteed, and the product development cycle can be shortened [12].

## 6. Conclusion

Embedded controllers are used in practically all types of devices, including mobile phones, home appliances, cars, and more. Embedded controllers have been used in a variety of fields, including industry, agriculture, education, national defense, scientific research, and day-to-day life, due to their small size, high reliability, strong function, flexibility, and convenience. These applications have helped to advance technological change, advance products, speed up the automation process, and increase productivity across all spheres of life. Nevertheless, there is still a substantial market for the creation of embedded systems. Embedded systems will become more practical and sophisticated in both daily life and business as science and technology advance.

## References

- [1] Chen G. Fundamentals of Single Chip Microcomputer Application Technology. China Machine Press, Beijing, 2015.
- [2] Wang C., Zhang F. Discuss the application of embedded DSP process. Kehai Story Expo·Science and Education Innovation, 2013.
- [3] Zhou Q., Wang J. Application and Development of Embedded System. Industrial Instrument and Automation Device, 2008, 67(3): 5.
- [4] Sang N. Embedded System Principle and Application Development Technology. Beijing University of Aeronautics and Astronautics Press, 2002.
- [5] Yang Y., Tang Y. Highly portable embedded system device driver architecture. Computer Engineering, 2006, 32(14): 271-273.
- [6] Shi M. Research on Software Design Technology of Embedded Application System. Computer Engineering and Application, 2002, 38(7): 44-48.
- [7] Seviora R. E., A Curriculum for Embedded System Engineering. ACM Transactions on Embedded Computing Systems, 2005, 4(3): 569-586.
- [8] Marinov M. T., Pavlov T. M. Rule-based decision support tools for injection moulding. International Journal of Knowledge-Based and Intelligent Engineering Systems, 2015, 19(2): 97-107.
- [9] Su P. Development Status of Embedded Operating System. Electronic World, 2012, 78(6): 19-20.
- [10] Ma Y., Liu Y., Zhang X. Current Situation and Development Prospect of Embedded System. Information Technology, 2001, 7(12): 301-307.
- [11] Dou X. Current Situation and Development Trend of Embedded System. Electronic Production, 2018, 6(3): 29-34.
- [12] Tan Z. Overview of Embedded System Application Status and Development Trend. Digital Technology and Application, 2015, 45(6): 108-114.
- [13] Yao X. Current Situation and Development Trend of Embedded Operating System. China New Technology and New Products, 2009, 23: 38-45.
- [14] Zhu C. Overview of Embedded System Application Status and Development Trend. Science and Technology Outlook, 2015, 40(13): 163-163.