

# Research on the Passive and Active Low Pass Filters

Hongze Fu<sup>1, †</sup>, Yunting Li<sup>2, \*, †</sup> and Qingyang Zhuo<sup>3, †</sup>

<sup>1</sup> Shandong University, Weihai, China

<sup>2</sup> South China University of Technology, Guangzhou, China

<sup>3</sup> Tianjin Yinghua International School, Tianjin, China

\* Corresponding Author Email: 202164020263@mail.scut.edu.cn

†These authors contributed equally.

**Abstract.** The goal of this paper is to demonstrate how to use Resistor-Capacitance circuit to build a low pass filter. One of the reasons for choosing to use the Butterworth filter was that it is characterized by a flat peak frequency response curve with no bandpass fluctuations and a gradual decay to zero in the stopband. It could also retain the same form regardless of orders or amplitudes. The low-pass filter is tuned to the RC circuit because its cutoff frequency is limited and the resistor's volume is smaller in this case. The authors realized that in the low-pass filter with operational amplifier and analog multiplier. To overcome the limitation and tackle the wave clipping problem, a negative feedback loop was introduced. On the output side, the authors also carry out research on latency reduction and make some progress. An operational amplifier was used to isolate the inputs from the outputs. In addition, the author reduced its latency and discussed its electrical principles.

**Keywords:** RC filter; operational amplifier; analog multiplier.

## 1. Introduction

Low pass filter is widely applied in electronic industry. Many researches are focused on the new design and improvement of the low pass filters.

A new defected ground structure for the microstrip line is proposed in [1]. The proposed DGS unit structure can provide the bandgap characteristic in some frequency bands with only one or more unit lattices. A novel photonic bandgap structure is proposed in [2] for increasing the stopband of a low-pass filter without the increasing circuit size for applications in microstrip circuits. Rahman et al. [3] examines the effect of the geometrical shapes of a defected ground-plane structure slot on performance of the Hi-Lo microstrip low-pass filter. The design and implementation of a fully integrated complementary metal-oxide-semiconductor sixth-order 2.4 Herzt low-pass filter for medical appliances was presented in [4]. In [5], a novel Hilbert curve ring (HCR) fractal defected ground structure (DGS) and its equivalent circuit are investigated. Furthermore, an improved HCR DGS cell model with open stubs loaded on the conductor line is then presented to improve the out-band suppression.

In this research, the authors focus on build a low-pass filter circuit. Low-filter is quite useful in daily life such as television and phone. The authors try to finish this task with clearer signal and faster transmission speed. Low-pass filter circuit could be divided into many kinds, such as Butterworth filter and Chebyshev filter. This time we choose Butterworth filter because it has smooth amplitude-frequency characteristics both inside and outside the passband. Undoubtedly, Butterworth filter distorts in transitional zone. The authors try their best to learn and solve the problem by changing circuit component and circuit configuration.

## 2. RC Filter Principles

RC circuitry is a filter circuitry that flickers at specific frequencies. It allows only low-frequency signals to pass through and blocks other frequencies [6]. It is a passive component meaning that it does not require any additional DC power to operate. The circuit consists of a resistor and a capacitor. Because it does not have transistors, operational amplifiers that require dc power to operate, all the

energy came from the ac signal component, while the current coming to the amplifier was generated by the DC power source. Thus, it will be possible for the AC signals to pass through this filter without any problems. So it cannot amplify the input ac signal. The RC Filter circuit is shown in Fig.1

Note that the filter the authors had constructed is a low pass filter, meaning that it can only accept frequencies from 0 Hz up to its cut-off frequency. The cutoff frequency is the frequency at which its gain decreases  $-3\text{dB}=0.5$ . If the frequency exceeds its cutoff frequency, the gain drops dramatically, so that the signal will be insignificant compared to low frequencies. It is possible to draw the magnitude-frequency plot in Bode plots via NI MULTISIM's AC Scan function. The response bode plot is shown in Fig.2. In addition, this circuit is generally known as a first- order filter. That is, it has only a single reactive component that is the capacitor. We can know by the root locus that it has a simple pole. As the frequency increases, the resistance of the capacitor drops. But the strength of the resistor's stays constant. This means that at low frequencies, the voltage potential of the capacitor will be larger and the voltage of the resistor will be smaller, thus outputting a larger voltage (by Ohm's law).

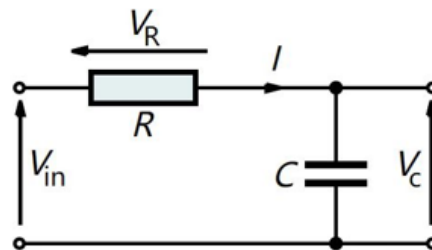

**Fig 1.** The circuit of RC low pass filter.

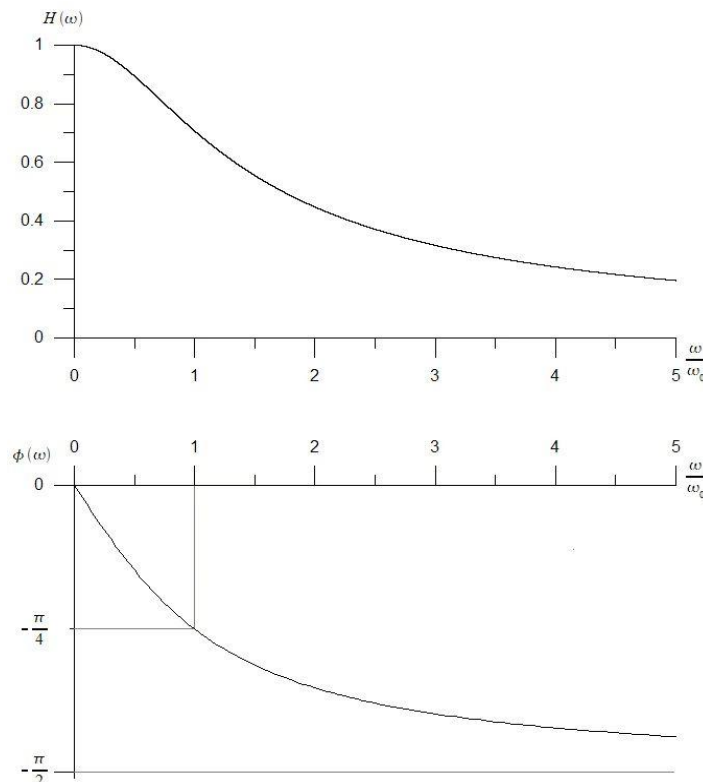

**Fig 2.** Amplitude-frequency and phase-frequency characteristics of RC low pass filter.

### 3. The Operational Amplifier and the Analog Multiplier

In electronics, an analog multiplier is a circuit that takes analog signals and outputs them multiplied by a constant (the resistance ratio between the feedback loop resistor and the negative ground input resistor) – a resistor that can be used as a source of electrical energy [7].

For this circuit, the operational amplifier's negative input is connected to the ground. And the positive input to the operational amplifier is plugged into the ac input function. The direct output from the operational amplifier is connected to the input through a resistor, and it builds negative feedback, which is essential for a tp operational amplifier circuit to function properly.

The operational amplifier is an active component with very large gains, shown in Fig.3. The active term means that it is coupled to  $V_{cc}$  which is dc power. Operational amplifier gains are usually extremely high, about 10, 000 greater than the voltage difference between the positive input voltage and the negative input voltage.

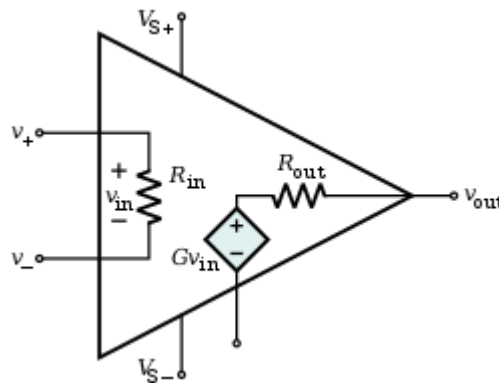

**Fig 3.** The operational amplifier.

The ideal operational amplifier can be simulated in a small signal model. In effect, it is a voltage-controlled voltage source. The open loop gain is infinite, the output resistance is equal to 0, and the input resistance is infinite.

Because of  $R_{in}$  being infinite. The following conclusions may be drawn. The sum of two input voltages equals zero, which is known as virtual ground. In addition, two input currents are equal to zero, which is called virtual short circuit. We can therefore have the following output voltage rules:

When the loop is closed, the outputs will do whatever it takes to ensure that the virtual ground and virtual short circuit property is satisfied. Even though this open-loop magnification is extremely high, the DC voltage we have provided is not infinite, if the output voltage wants to surpass DC's maximum providing capability, the output will be limited to the DC's maximum providing capability, thus causing saturations, and it means the signal will not be provided linearly, which causes signal loss.

One way of reducing this is to introduce negative feedback to reduce the magnification of the operational amplifier circuitry. The authors in this case connected a resistor between the output and the negative feedback. This corresponds to a feedback amplitude of  $1k\Omega/1k\Omega=1$ , which is much smaller than the open-loop magnification. For example, the closed-loop magnification of the circuit can be viewed as  $1/\text{feedback-magnification}$ . Therefore, it is equal to 1. The clipping problem can be greatly reduced by reducing the magnification of the circuit.

#### 4. Outputs and Refinement

Using the AC sweep function of the NI Multisim, shown in Fig. 4, we can obtain the output amplitude and output phase shift as a function of different input frequencies. Because of the fact that the magnified magnitude is large. He uses the decibels as the unit of the y-axis. Based on this map. Both of these maps are widely known as bode plots. What makes it different from traditional plots is that the frequency or x axis is shown via a logarithmic magnitude, so it can show the frequency response much more easily. Using the operational amplifier 741, however, the latency problem is very large.

If the input sinusoidal function is replaced in a step function generator, the oscilloscope can tell us that the latency is approximately 0.8s, which is not ideal. However, circuit latency was not reduced, and the authors initially tried to reduce the capacitor while keeping  $RC=1$ . By changing the lineal

amplifier to Texas Instruments OP348 in its place. The author found that the latency problem was halved to 0.4s.

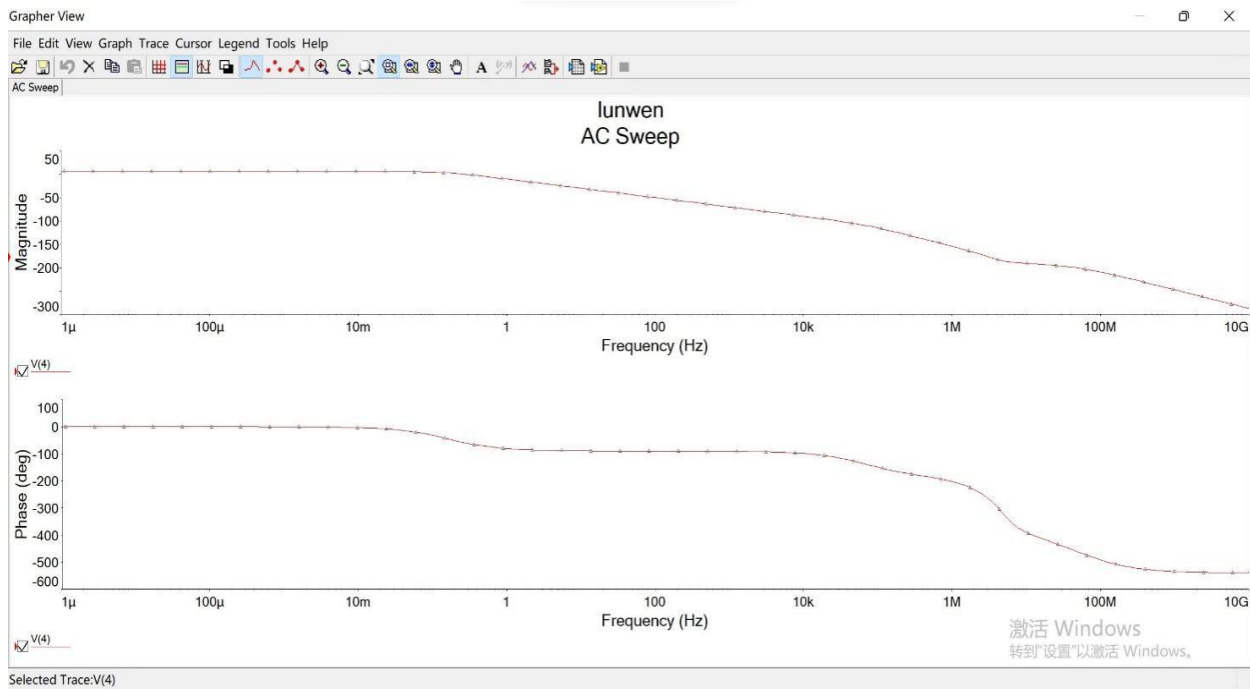

Fig 4. The output graph.

#### 4.1. Electric principles inside uA741

Since both uA741 and OPA348 is a Texas Instrument (TI) device, but the functional block diagram of op348 is unavailable, the author uses uA741 [8] as an example to discuss the electric principle inside general purpose operational amplifiers. The circuit diagram is shown in Fig. 5.

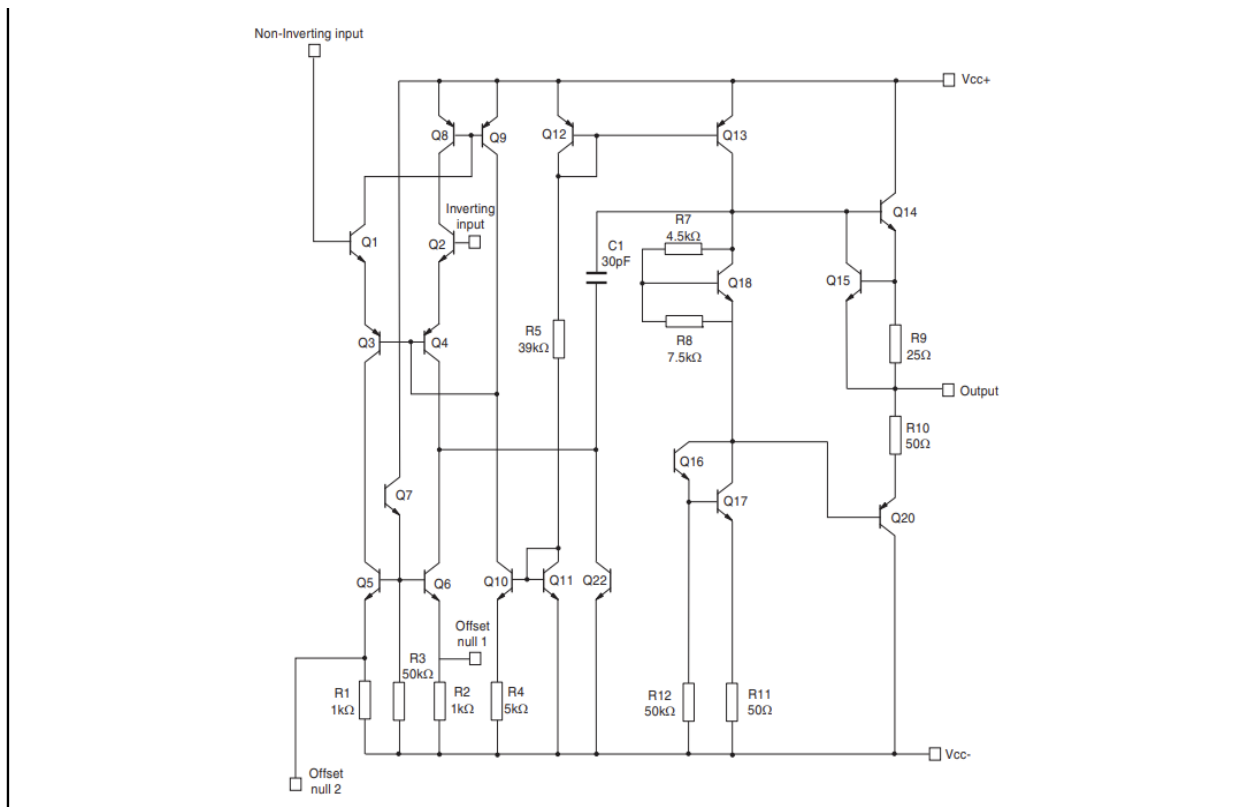

Fig 5. Circuit diagram of uA741.

Because the size of uA741 is small, by using a micro-current circuit, the power consumption and thermal problem can be reduced.

The bias circuit of uA741 is a combination of current sources, consists of Q8, Q9, Q12, Q13, Q10 and Q11. Q2, Q10 and Q11 consists of its main bias circuit. It provides a bias DC current  $I_{reference}$  (Q11) for backside circuits to work properly. In the same time,  $I$  (Q10) provides a much smaller current for frontside circuits. The current of Q10 comes from Q8 and Q9, which is a mirroring current source. Q12 and Q13 is a dual-output mirroring current source. One part of the output of Q13 is provided to the output layer as a bias current and the other part is provided to the middle layer as the bias current and a sourced load.

The input layer is basically a series of differential amplification circuit, consists of Q1-6. Q1, Q2 is a common-collector differential amplification circuit aiming to increase the input impedance. Q3 and Q4 with the sourced input load of Q5, Q6 and Q7 is beneficial to increase the output voltage amplification and improve frequency response and sound noise ratio. By using a sourced load, it is more symmetry thus improves sound noise ratio.

The middle part is also used as a voltage magnification layer. It consists of Q16 and Q17, Q17 acts as a load to Q16, and thus the AC load is very big, increasing voltage gain and input impedance.

The output layer consists of Q14 and Q20, which is fundamentally a complementary symmetrical circuit. It is a type AB circuit which is good for reducing crossover distortion while still maintaining an acceptable efficiency. In order to function, type AB circuit needs a DC bias which is provided by Q19 and Q18. It also uses voltage b-e of Q19 and Q18 to construct a negative feedback loop, improving stability. Q13 provides it with static work current.

Response time was compared between uA741 [9] and OPA348 [10]. The only difference between two circuits is the selection of operational amplifiers. By consulting Texas Instrument's technical manual, the reason for latency reduction can be found.

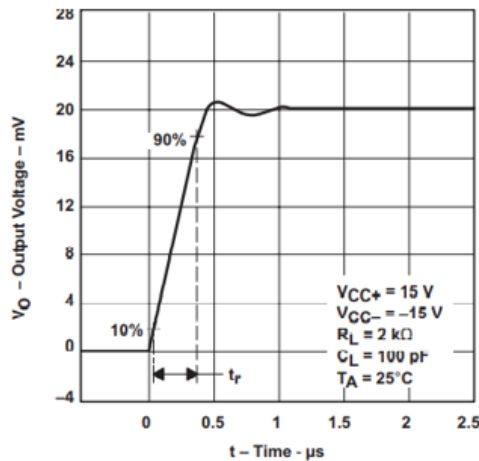

Fig 6. Output voltage vs elapsed time of uA741.

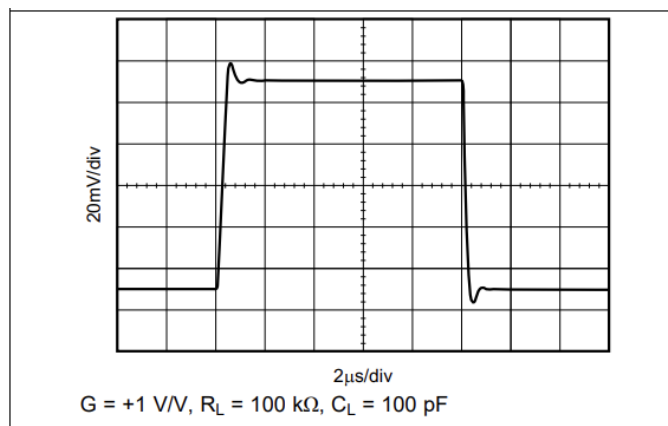

Fig 7. Small-signal step response of uA741.

Comparing Fig.6 and Fig.7, it is obvious that the OPA348 has a much faster response.

The most common low-pass filters are Butterworth, Chebyshev and Bessel. Butterworth filters have a property of the smoothest frequency response, however the smooth curve dictates that the degradation from the pass band to the filter band is slow and not obvious, which is not ideal, thus in the real application, sometimes we need multi-stages Butterworth to achieve ideal output sound noise ratio. The Chebyshev has fastest degradation speed, but there are spikes near the degradation thus ripple waves can be seen in the output, requiring smoothing circuits. The Bessel is more focused on the phase shift, which means the phase shift is linear to the frequency, can output a less distorted wave. In most applications, we still use Butterworth because of its smoothness, by using a multistage Butterworth, we can get an ideal output.

## 5. Conclusion

The authors use a resistor-capacitor circuit to build a low-pass filter-Butterworth filter-because he is a flat maximum frequency response curve. The circuit RC is tuned with the low-pass filter because its cutoff frequency is limited and the resistor's volume is smaller in this case. By using an operational amplifier, the output voltage is isolated to the input load. The authors construct a negative feedback  $p$ , to solve the wave shear caused by the operational amplifier. In terms of output the authors obtained by conducting a delay reduction study to improve response time.

## References

- [1] Ahn D, Park J S, Kim C S, et al. A design of the low-pass filter using the novel microstrip defected ground structure. *IEEE Transactions on Microwave Theory & Techniques*, 2001, 49(1):86-93.
- [2] Kim T, Seo C. A novel photonic bandgap structure for low-pass filter of wide stopband. *IEEE Microwave and Guided Wave Letters*, 2000, 10(1):13-15.
- [3] Abdel-Rahman A B, Verma A K, Boutejdar A, et al. Control of bandstop response of Hi-Lo microstrip low-pass filter using slot in ground plane. *IEEE Transactions on Microwave Theory & Techniques*, 2004, 52(3):1008-1013.
- [4] Solis-Bustos, Sergio, Silva-Martinez, A 60-dB Dynamic-Range CMOS Sixth-Order 2.4-Hz Low-Pass Filter for Medical Applications. *IEEE Transactions on Circuits & Systems Part II Analog & Digital Signal Processing*, 2000.
- [5] Chen J, Weng Z B, Jiao Y C , et al. Lowpass Filter Design of Hilbert Curve Ring Defected Ground Structure. 70, (2007), 2007, 70:269-280.
- [6] Guanyuan Qiu, *Circuits*, 2006, ISBN 978-7-04-019671-9:69-71.
- [7] Walt Jung, *Op Amp Applications Handbook*, 2004, ISBN 0-7506-7844-5:5-23.
- [8] Huaguang Kang, *Basics of Electronic Technology (Analogue Part)*, 2005, ISBN 978-7-04-017789-3:281-284.
- [9] Texas Instruments Inc. ,ua741 general purpose amplifier, 2018, <https://www.ti.com.cn/product/cn/UA741:9>.
- [10] Texas Instruments Inc. ,OPA348 Operational Amplifiers, 2016, <https://www.ti.com.cn/document-viewer/cn/OPA348:11>.