

Analysis of bit error rate of pulse position modulation in free-space optical communication

Youran Wang *

University of Electronic Science and Technology of China, China, Sichuan Province 611731

* Corresponding Author Email: 2020050908004@std.uestc.edu.cn

Abstract. Pulse Position Modulation (PPM) modulation is a widely used modulation method in free-space optical (FSO) communication, which has many medium forms. This work introduces and summarises the three main PPM modulation methods, L-ary pulse position modulation (L-PPM), L-ary differential pulse position modulation (L-DPPM), and L-ary multiple pulse position modulation (L-MPPM), and summarises their respective characteristics and suitable usage scenarios. At the same time, this study analyzes several cases of combining coding methods with PPM modulation methods and finds that the right coding method can make PPM modulation methods more valuable. In addition, receiver diversity and/or aperture averaging can both improve the connection error performance.

Keywords: Pulse Position Modulation, free-space optical communication.

1. Introduction

Technological and scientific advances have led to laser technology has gradually matured, the quality of the laser beam has improved and the laser beam now has more power. beams are also being used in more and more areas. Due to the high brightness, high frequency, good monochromaticity, and directionality of the laser, the laser beam is used as a medium for information dissemination, which is often referred to by us as FSO communication[1]. The properties of the laser make FSO communication directional, confidential, and broadband, which makes FSO communication widely used and overcomes the limitations of fiber optic communication[2].

However, atmospheric optical communication also has its limitations. Owing to the impacts of laser beams on the earth's atmosphere reflection and dispersion, and the turbulent nature of the atmosphere, the propagation of lasers in the atmosphere can be strongly interfered with, affecting the propagation of information, which is the biggest challenge for FSO communication today Therefore, finding suitable methods to reduce the impact of the atmosphere on system performance has been widely investigated. One important approach is to mitigate the effects of atmospheric turbulence by using suitable modulation methods[3].

The most commonly used intensity modulation in FSO communication systems is On-Off Keying (OOK) and Digital PPM. Studies have shown that traditional OOK modulation, although simple and intuitive, has a lower power utilization compared to PPM modulation. For the same average emitted optical power, PPM signals have higher peak optical power, i.e. better signal-to-noise ratio and stronger interference immunity[4]. There are many different forms of PPM modulation, such as DPPM[5], combinatorial PPM [6], MPPM[7], overlapping PPM[8]. At the same time, new PPMs have emerged that combine the above PPMs to meet different needs. Overlapping MPPM (OMPPM), a combination of OPPM and MPPM, was first proposed by the authors of [9]. With this composition, one channel is represented by a range of different pulse locations. The differential overlapping PPM (DOPPM) has been demonstrated in [10].

This work summarises the characteristics of L-PPM, L-DPPM, and L-MPPM. The advantages of the three modulation methods and their performance in different scenarios are summarised by comparing the characteristics of the three modulation methods and the appropriate scenarios for their use. Also, the effect of different coding methods on different PPM modulations. This study finds that when the coding method is chosen appropriately, energy efficiency may be increased while BER can be decreased, so finding the right coding method to work with PPM modulation is also a way to address the effects of atmospheric turbulence. The following paper is divided into three parts, the first

part is an introduction to the three modulation methods, the second part is a specific case study and a comparison and analysis between the three modulation methods, and the last part is a summary.

2. Theoretical knowledge

2.1. The basic theory of L-PPM

As the basis for all pulse modulation methods, single pulse modulation is the simplest pulse modulation method. Unit pulse modulation is modulated in groups, each group corresponding to a symbol and each symbol corresponding to a certain number of time slot bits. Let the code element to be modulated contain a total of n bits of binary information, denoted as $L = (l_1, l_2, \dots, l_n)$. Each code element contains time slots, but only one-time slot has a light pulse at its position, the other time slots have no light pulses, so a binary n -bit data set is mapped as a single pulse at a time slot on a period consisting of 2^n time slots. Each light pulse's time slot position might thereafter stand in for a separate piece of data. The mapping code relationship for single-pulse PPM modulation may be stated as follow, where l denotes the time slot position [11] $s = 2^0 l_1 + 2^1 l_2 + \dots + 2^{n-1} l_n$

Each code element can carry n bits of information. The quantity of information carried by each other code element is directly impacted by the time slot of a code element. With a 4-PPM modulation.

For a PPM with a time slot of length L_0 , the amount of information (bits) transmitted is

$$n = \log_2 L_0 \tag{1}$$

Thus the average bit rate per time slot is $\log_2 L_0 / L_0$.

The signal diagram for 4-PPM modulation is shown in Fig.1 and it can be seen that each symbol it has the same length.

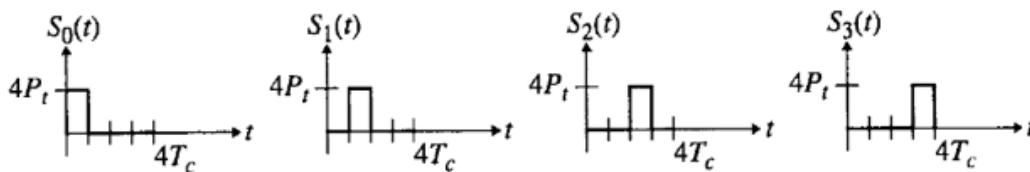

Fig 1. The signal diagram for 4-PPM modulation

Table 1. a code for PPM modulation

Source bits	Corresponding 4-PPM chips (nominal mapping)
00	1000
01	0100
10	0010
11	0001

Tab.1 is an illustration of a PPM modulation code, which can be seen to have the same time slot for each symbol.

2.2. The basic theory of L-DPPM

DPPM is a modified version of PPM. Both share the same basic idea of using pulse position information to correspond to the bit signal. However, DPPM has a higher bandwidth utilization compared to PPM. To maximize bandwidth utilization, the light pulse-free time slots after each set of time slots are omitted to maximize the bandwidth utilization [11].

The signal diagram for 4-PPM modulation is shown in Fig.2 and it can be seen that each symbol it has a different length.

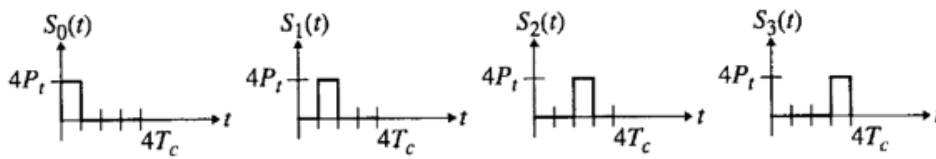

Fig 2. The signal diagram for 4-DPPM modulation

Table 2. a code for DPPM modulation

Source bits	Corresponding 4-PPM chips (nominal mapping)	Corresponding 4-DPPM chips (nominal mapping)
00	1000	1
01	0100	01
10	0010	001
11	0001	0001

Tab.2 is an illustration of a PPM modulation code, which can be seen to have the same time slot for each symbol.

2.3. The basic theory of L-MPPM

An alternative and improved modulation to PPM is MPPM, which corresponds to the same time slot length for each code element, as PPM. The difference is that for PPM there is only one light pulse in a set of time slots, but for MPPM there are multiple light pulses. Specifically, if m of the L time slots of the MPPM have light pulses, then all combinations are[12]

$$C_L^m = \frac{L!}{m!(L-m)!} \geq 2^n \tag{2}$$

From this, this study can see that MPPM can greatly improve the transmission efficiency of the channel. Fig.3 shows one model of MPPM, from which it can be seen that each code element corresponds to 16-time slots, but only two of them have optical pulses.

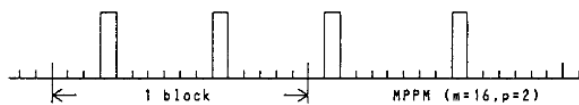

Fig 3. The signal diagram for DPPM modulation when L = 16, m = 2

2.4. The basic theory of bit error rate (BER)

During FSO communication, the source signal is affected by noise and atmospheric turbulence as it travels through the channel, which can cause errors in the received signal. The quantity of bit errors in a data stream refers to how many bits in the received channel have been changed as a result of noise, interference, loss, or bit synchronization issues. The BER is derived by splitting the number of bits sent over time by the number of bits that were incorrectly transmitted. BER, which measures performance without utilizing even a single bit, is typically given as a percentage. BER measures the correctness of data transmission over a certain period and may be thought of as a rough estimate of

the chance of error. It is more accurate for long periods and large error bits. The basic theory of atmospheric turbulence models.

Since atmospheric turbulence is the main cause of errors in FSO communications, a reasonable and effective model of atmospheric turbulence is necessary. Atmospheric turbulence models can be divided in terms of intensity into, weak turbulence, medium to strong turbulence, and strong turbulence. While evaluating the influence of the atmosphere on the communication system, it is equally vital to examine the function of weather.

3. Cases of application of PPM modulations

In the previous article, this study introduced the basic principles of the three PPM modulation methods, but in a complete optical communication system, PPM modulation is used in different scenarios together with the coding and detection methods. Since different modulation methods have different characteristics and there are different coding and detection methods for the same modulation method, numerous studies have been done on the variety of applications for different modulation systems. In this chapter, this study will analyze the application of different PPM modulations in different coding methods and scenarios[13]–[15].

3.1. BER of PPM and DPPM in the Fading channel in the case of BCH coding

In the study by Sonali et al. L-PPM and L-DPPM’s BER in the Fading channel in the case of BCH coding was studied[15]. Fig. 4 is a model diagram of the system. Using L-PPM and DPPM methods, direct detection (DD) and intensity modulation linkages are utilized. Between the source and the detector, there is a fading channel that follows a gamma-gamma(G-G) distribution. BCH codes are used to reduce fading's negative effects. The message bits are sent to the BCH encoder, which switches the bit ordering before communication, and then to the interleaved. Before being handled by the BCH decoder at the receiver side, the bits are deinterleaved. As part of the FSO-coded communication Transmission system's signal processing, the channel coder appropriately encrypts the data and obtains the initial information from the channel decoding. The interleaved and non-interleaved blocks are represented by dashed lines and are not required.

One of the most well-liked models of atmospheric turbulence is the G-G distribution, which could be employed to characterize the fluctuations in irradiance of turbulent noise in the atmosphere that occur from big and small turbulent eddies. The G-G distribution, which is the product of the multiplication, enables the best modeling of the weak, medium, and high turbulence regimes.

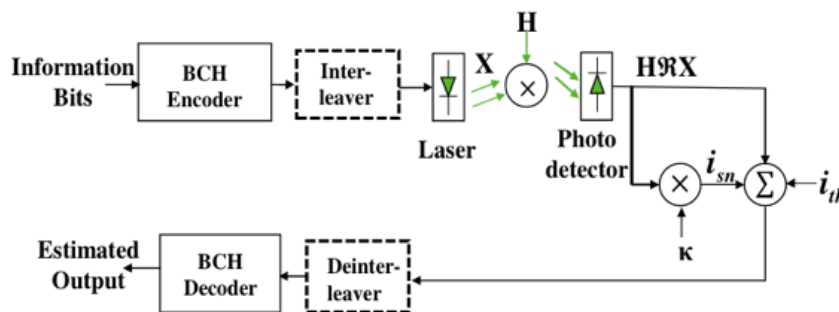

Fig 4. BCH-coded FSO communication network block diagram.

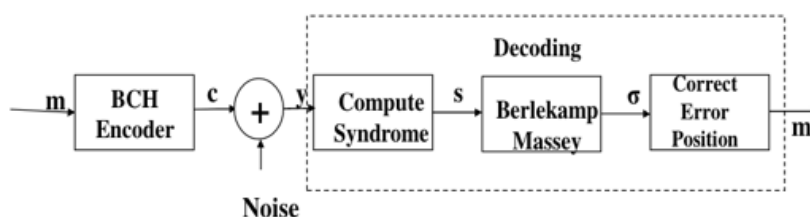

Fig 5. Block diagram of BCH decoder.

Fig. 5 is a Block diagram of the BCH decoder. It is the source of the message sequence to be sent according to a set k -bit group divided into message groups, and then each message group will be individually changed into n ($n > k$) binary digital groups, known as code words. BCH codes are a significant family of error-correcting codes. The entire set of the M code words so obtained will be known as the group code with code length n and several messages M , noted as n, M if there are M message groups (clearly $M \geq 2$).

The findings of the aforementioned study are depicted in Fig. 6, which demonstrates that the ppm scheme virtually completely ignores the application of the BCH code in the same turbulent environment. If the backup plan is unsuccessful, having a backup plan is a smart idea. No coding advantage is possible for the DPPM scheme because the variable symbol length of the BCH codes prevents them from being able to solve the error propagation issue on their own. Interleavers are also not used to enhance performance.

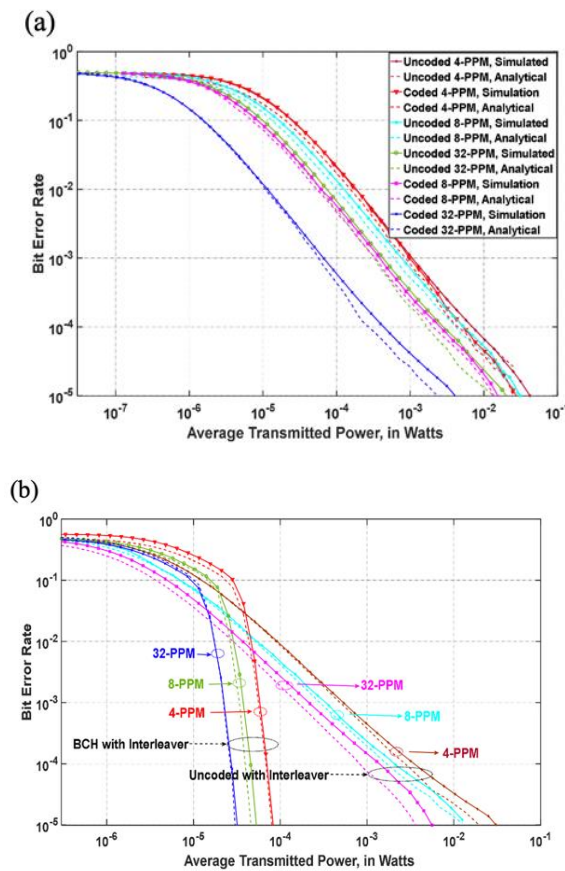

Fig 6. The relationship between Average Transmitted Power and BER; (a) Analytical and simulation results without interleaved; (b) Analytical and simulation results with interleaved.

3.2. The BER of L-PPM and L-MPPM in the photonic communication system

In the study by Masahiko Takahasi et al., the capacities of L-PPM and L-MPPM were compared in the photon counting channel [13], while the effect of the RS coding method on the two modulation methods was also investigated. As a very unique system with extremely minimal noise, the photonic communication system can be assumed to be noiseless in this study.

For valid polynomials produced from corrected oversampled data, Reed-Solomon codes are forward error-corrected channel codes. These polynomials are first redundantly evaluated throughout the coding process at several places before being transmitted or stored. The polynomials are overdetermined as a result of the oversampling beyond the required values. Even though many of the received polynomial's points are distorted by noise interference, it can restore the original polynomial after the receiver has correctly received enough points.

Uncoded MPPM greatly increased transmission rates and energy efficiency in noise-free photonic communications, according to this study. Moreover, Reed-Solomon codes were used for MPPM to increase transmission efficiency. Within a reasonable range of error probabilities, RS-encoded MPPM was able to reach an energy efficiency that was more than twice as high as RS-encoded PPM. The link between the block error rates of the two modulation techniques is depicted in Fig.7. Although having a greater utilization efficiency, MPPM has a higher overall error rate than PPM.

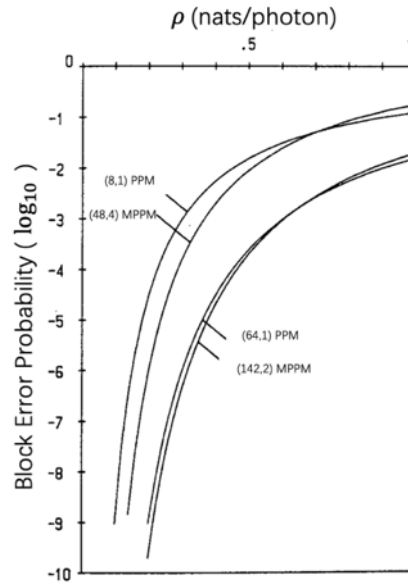

Fig 7. Block error probability of MPPM.

3.3. BER of PPM and DPPM in free-space downlink

In free-space downlink conditions with air turbulence, the BERs of PPM and DPPM are compared in the study by Anjitha Viswanath et al[14]. Moreover, the impact of various detection methods on both coding systems is examined. The study makes suggestions for the use of coding algorithms in FSO communications while considering different turbulence scenarios and weather patterns. The analysis includes an FSO downlink, which employs one transmitter and a multitude of receivers to connect the GEO satellite to an Earth station. Because of its convenience and simplicity of execution, an intensity-modulated transmitted signal with a DD approach is used at the receivers. The network under examination is a single input multiple outputs (SIMO) system comprised of one satellite-borne transmitter and several ground-based receivers (illustrated in Fig. 8). By adding background noise into the information stream, the optical channel, on the other hand, drastically decreases receiver performance and may even cause link failures. The biggest source of background noise is the sun. An optical bandpass filter (OBPF) put in front of the reception optic can lessen the impact of the noise level by lowering background radiation on the photodetector.

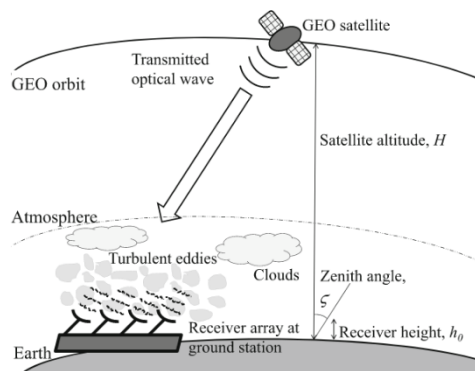

Fig 8. Schematic representation of a satellite to ground station Free space optical downlink

The overall channel state pdf of the satellite-to-earth FSO downlink is computed using a log-normal pdf for minor turbulence and a G-G pdf for moderate to massive turbulence.

The BER of the M-DPPM and M-PM systems is examined using this pdf. Also, the effectiveness of link BER enhancement using methods for reception variety and apertures average is examined. Under clear, turbulent, mild, light, and foggy circumstances, the variation in BER of the average received power is examined. When there is a lot of fog and cloud cover, FSO connectivity may break. Moreover, receiver diversity and/or aperture averaging can both enhance connection error performance. Increases in receiver diameter and the quantity of DD receivers both improve error performance.

Table 3. average received power (dbm) required for ber

IM scheme	Weather conditions	Required average received power (dBm) for a BER of 10^{-6}			
		Point receiver		Finite aperture receiver	
		$D = 1$ cm $R = 1$ no.	$D = 16$ cm $R = 1$ no.	$D = 8$ cm $R = 4$ nos.	$D = 4$ cm $R = 16$ nos.
OOK	Turbulence + Moderate fog	-8.35	-24.60	-25.38	-26.02
	Turbulence + Light fog	-10.26	-26.34	-27.12	-27.76
	Turbulence + Thin fog	-11.55	-27.55	-28.32	-28.97
	Turbulence + Clear air	-12.04	-28.01	-28.79	-29.43
64-DPPM	Turbulence + Moderate fog	-16.08	-33.02	-33.80	-34.45
	Turbulence + Light fog	-18.22	-34.77	-35.55	-36.19
	Turbulence + Thin fog	-19.63	-35.98	-36.76	-37.40
	Turbulence + Clear air	-20.16	-36.44	-37.22	-37.86
64-PPM	Turbulence + Moderate fog	-17.09	-34.48	-35.27	-35.91
	Turbulence + Light fog	-19.37	-36.24	-37.01	-37.65
	Turbulence + Thin fog	-20.85	-37.45	-38.23	-38.87
	Turbulence + Clear air	-21.41	-37.91	-38.69	-39.33

3.4. Comparison and summary of different PPM modulation methods

As this study knows from the previous section, different modulation methods exhibit different performances under different coding and signal environments. In the following, this study will summarize and analyze the application of the different PPM modulation methods.

Firstly, as a recently emerged PPM modulation method, PPM has the advantage of being simple and stable, showing strong stability in atmospheric turbulence, but its use of bandwidth is inefficient.

As a special form of PPM, DPPM has the advantage of increasing the efficiency of bandwidth utilization. However, the difference in the length of the time slot groups corresponding to the core elements of DPPM makes it more error-prone as an error at one point in DPPM can lead to errors not only in the transmission of that code element but also in the transmission of subsequent code elements. MPPM, a special form of PPM, is more complex, but has a higher capacity, is more efficient, and has a lower error rate than DPPM.

Tab.4 below summarizes the advantages and disadvantages of the different PPM modulation methods and their possible use scenarios. In particular, PPM is more suitable for long-range scenarios with high channel interference due to its stability, while MPPM is more suitable for short-range scenarios with low channel interference thanks to it, while DPPM is likely to be used for short-range communications where channel capacity is not very demanding due to its ease of implementation.

Table 4. Comparison of the three types of PPM

	Complexity	BER	Suitable coding methods	Applicable scenarios
PPM	Easy	Lowest	BCH code	Long distance communication
DPPM	Moderate	Highest	-	Easy-to-implement short-range communication
MPPM	Difficult	Moderate	RS code	Highly efficient short-range communication

In addition, when utilizing modulation methods, it is also important to consider the combination with coding methods, as an excellent combination can allow the advantages of different modulation methods to be enhanced and the disadvantages to be compensated for. At the same time, the use of several devices and methods can make PPM modulation methods more useful in optical communication systems. For example, receiver diversity and/or aperture averaging can both improve connection error performance.

4. Conclusion

In this work, this study first introduced the modulation methods and characteristics of each of PPM, DPPM, and MPPM, and then combined them with three specific examples for comparison and analysis. In the end, this study found that PPM, DPPM, and MPPM all have their suitable usage scenarios due to their respective characteristics. Firstly, in terms of complexity, PPM is the easiest to implement, while MPPM is the most difficult to implement. Of the three modulation methods, PPM is the most robust against turbulence and has the lowest BER, making it the most suitable for long-distance communications. DPPM and MPPM are more energy efficient and therefore suitable for high-efficiency communications.

At the same time, the use of a combination of coding methods and PPM modulation methods can have a substantial influence on effectiveness. When the right coding method is adopted, PPM modulation will give better performance. For example, the use of RS coding can increase the energy efficiency of MPPM by a factor of two, while the use of BCH coding can reduce the BER of PPM. However, BCH coding has almost no effect on DPPM.

In addition, other devices in the system can have an impact on PPM modulation. For example, in FSO downlink communications, receiver diversity and/or aperture averaging can both improve PPM and DPPM performance. And when both interleaved and BCH coding is used, the ability of PPM to resist turbulence can be improved.

References

- [1] J. Hecht, "A short history of laser development," *Appl. Opt.*, vol. 49, no. 25, p. F99, Sep. 2010, doi: 10.1364/AO.49.000F99.
- [2] M. A. Khalighi and M. Uysal, "Survey on Free Space Optical Communication: A Communication Theory Perspective," *IEEE Commun. Surv. Tutor.*, vol. 16, no. 4, pp. 2231–2258, 2014, doi: 10.1109/COMST.2014.2329501.
- [3] H. Kaushal, V. K. Jain, and S. Kar, *Free Space Optical Communication*. New Delhi: Springer India, 2017. doi: 10.1007/978-81-322-3691-7.
- [4] G. A. Mahdiraji and E. Zahedi, "Comparison of Selected Digital Modulation Schemes (OOK, PPM and DPIM) for Wireless Optical Communications," in *2006 4th Student Conference on Research and Development*, Shah Alam, Malaysia, Jun. 2006, pp. 5–10. doi: 10.1109/SCORED.2006.4339297.
- [5] D. Zwillinger, "Differential PPM has a higher throughput than PPM for the band-limited and average-power-limited optical channel," *IEEE Trans. Inf. Theory*, vol. 34, no. 5, pp. 1269–1273, Sep. 1988, doi: 10.1109/18.21255.

- [6] J. M. Budinger, M. J. Vanderaar, P. K. Wagner, and S. B. Bibyk, "Combinatorial pulse position modulation for power-efficient free-space laser communications," presented at the OE/LASE'93: Optics, Electro-Optics, & Laser Applications in Science& Engineering, Los Angeles, CA, Aug. 1993, p. 214. doi: 10.1117/12.149237.
- [7] D. A. Fares, "Heterodyne detection of multipulse signaling in optical communication channels," *Microw. Opt. Technol. Lett.*, vol. 9, no. 4, pp. 201–204, Jul. 1995, doi: 10.1002/mop.4650090411.
- [8] C. N. Georghiadis, "Modulation and coding for throughput-efficient optical systems," *IEEE Trans. Inf. Theory*, vol. 40, no. 5, pp. 1313–1326, Sep. 1994, doi: 10.1109/18.333850.
- [9] T. Ohtsuki, I. Sasase, and S. Mori, "Performance analysis of overlapping multi-pulse pulse position modulation (OMPPM) in noisy photon counting channel," in *Proceedings of 1994 IEEE International Symposium on Information Theory*, Trondheim, Norway, 1994, p. 80. doi: 10.1109/ISIT.1994.394890.
- [10] T. Ohtsuki, I. Sasase, and S. Mori, "Differential overlapping pulse position modulation in optical direct-detection channel," in *Proceedings of ICC/SUPERCOMM'94 - 1994 International Conference on Communications*, New Orleans, LA, USA, 1994, pp. 680–684. doi: 10.1109/ICC.1994.368797.
- [11] Da-Shan Shiu and J. M. Kahn, "Differential pulse-position modulation for power-efficient optical communication," *IEEE Trans. Commun.*, vol. 47, no. 8, pp. 1201–1210, Aug. 1999, doi: 10.1109/26.780456.
- [12] D. A. Fares, "Heterodyne detection of multipulse signaling in optical communication channels," *Microw. Opt. Technol. Lett.*, vol. 9, no. 4, pp. 201–204, Jul. 1995, doi: 10.1002/mop.4650090411.
- [13] M. Takahasi, H. Yashima, I. Sasase, and S. Mori, "Capacity and effects of Reed-Solomon codes on multi-pulse PPM in optical communications," in *IEEE International Conference on Communications, Including Supercomm Technical Sessions*, Atlanta, GA, USA, 1990, pp. 1663–1667 vol.4. doi: 10.1109/ICC.1990.117345.
- [14] A. Viswanath, V. K. Jain, and S. Kar, "Aperture averaging and receiver diversity for FSO downlink in presence of atmospheric turbulence and weather conditions for OOK, M-PPM and M-DPPM schemes," *Opt. Quantum Electron.*, vol. 48, no. 9, p. 435, Sep. 2016, doi: 10.1007/s11082-016-0706-8.
- [15] Sonali, N. Gupta, A. Dixit, and V. K. Jain, "BER analysis of BCH codes in slow fading channel with L-ppm and DPPM scheme," 2018 IEEE International Conference on Advanced Networks and Telecommunications Systems (ANTS), 2018.