

FPGA-based PPM Modulation System Design

Jiarun Yang *

Southwest Jiaotong University, Chengdu, China

* Corresponding Author Email: yang.jiarun@my.swjtu.edu.cn

Abstract. As a widely used modulation technique in the field of communication, PPM modulation techniques have the advantages of high interference immunity, simple coding and high-power utilization, and are often applied in practical scenarios. PPM modulation techniques can be divided into three categories. single pulse position modulation, differential pulse position modulation and multi pulse position modulation. In different application scenarios, different kinds of pulse position modulation methods should be selected for modulation. In this paper, the frame structures of these three types of pulse position modulation are discussed using the Verilog language based on FPGA, the corresponding mapping relationships for each type of pulse position modulation are given, and the design and performance of these three types of pulse position modulation demodulation systems are compared.

Keywords: Pulse Position Modulation (PPM), Field Programmable Gate Array (FPGA), Differential Pulse Position Modulation (DPPM), Multi Pulse Position Modulation (MPPM)

1. Introduction

In recent years, PPM modulation techniques have been widely used in many communication fields such as optical, mobile, molecular and IoT communications. 1978, J.R. PIERCE first proposed and applied PPM modulation to space communications [1]. 1982, G PRATI et al. extended PPM coding to block pulse coding containing multiple PPM frames and developed a maximum likelihood decoding operation for scattered particle noise-limited and thermal noise-limited optical receiver models developed a maximum likelihood decoding operation [2]. In 1985, O'Reilly et al. identified and studied a class of finite-state alternating alphabetic line codes called mBL-K, in the context of digital pulse position modulation (PPM) [3]. In 1987, R Gagliardi et al. investigated the problem of finding a non-periodic PPM acquisition sequence with minimum possible autocorrelation for all offset positions and found a sequence with the maximum possible frame size of 15 [4]. In 1992, Robert et al. examined the potential of digital pulse position modulation (PPM) as the preferred modulation format for ideal photon counting channels and optical inter-plate links in coherent fibre optic communication channels. They provided a comprehensive performance and optimization analysis comparing scattering noise limited coherent PCM [5]. In 1997, Lee, D.C.M et al. analyzed the performance of grid-coded pulse position modulation (PPM) over indoor wireless infrared channels and gave Monte Carlo simulation results for 8-PPM at high constraint length, rate 2/3, and 16-PPM codes at rate 3/4 [6]. As it enters the 21st century, PPM modulation and demodulation-related applications are becoming more sophisticated, and the results are numerous.

In the last five years, several scholars have innovatively used PPM for applications in communications. in 2018, BC Akdeniz et al. modified the conventional PPM modulation due to its robustness to ISI. They proposed a new modulation scheme in molecular communications using a single type of molecule and a corresponding simple receiver structure [7]. In the same year, Zhang Fan et al. used the full diversity set and high coding gain of the space-time grid code to obtain higher optical power utilization in combination with PPM modulation while effectively overcoming the effect of atmospheric turbulence on optical communication systems [8]. In 2020, M Biagi et al. proposed a PPM-based space-time packet coding, a coding system capable of providing higher spectral efficiency at the cost of higher symbol error rate [9]. In the same year, Kanchan Sharma et al. used a hybrid pulse position modulation technique of PPM-BPSK-SIM using wavelength and time diversity to study free-space optical communication systems and derived average BER and closure expressions by using lognormal and γ - γ probability density functions as channel fading statistics

under weak, moderate and strong turbulence [10]. In 2021, D Zou et al. proposed correlated-domain uncertain pulse position modulation (CDIPPM) to enable a unified signal system for simultaneous high-precision positioning and high-speed data transmission in satellite navigation and communication integration (SNCI) [11]. In 2022, Binyu Li et al. adjusted the PPM's modulation parameters by analyzing the experimental site's meteorological statistics and selected the appropriate modulation order and initial pulse width to improve the data transmission rate of the deep space optical communication (DSOC) system [12]. In the same year, Wang Fengying et al. combined chaotic spread spectrum with pulse position modulation (PPM) technology to study the effect of the foggy sky on the BER of the Chaotic Pulse Position Modulation (CPPM) LED optical communication system [13]. PPM modulation has gone from the initial exploration to the depth of today, from single PPM modulation to PPM with a mixture of multiple modulation methods. In this paper, three PPM modulation systems are discussed and analyzed in detail, based on the way the FPGA works.

This paper first introduces the historical background of PPM modulation and the latest progress, summarises the main PPM modulations worldwide and classifies them into three categories according to the modulation methods and their mapping relationships. single pulse position modulation, differential pulse position modulation and multi pulse position modulation. After the three modulations' basic principles and mapping relationships, this paper introduces the modulation using Verilog language based on the FPGA working method. Simulation verification using Quartus, Modelsim, and a detailed explanation of the modulation and demodulation structure, flow analysis and comparison of performance, parameters and operating scenarios of the three PPM modulation systems are presented.

As PPM modulation techniques have matured, PPM has been used to improve communication performance by combining it with other coding methods, such as LDPC codes [14]. In addition, PPM has evolved from its initial application in single-input single-output (SISO) communication systems to its current application in multiple-input multiple-output (MIMO) communication systems [15].

2. Principle of PPM

2.1. Structure of PPM

The advantages of PPM modulation, a pulse modulation technique developed for decades, are its higher power utilization, simpler coding and better immunity to interference. There are many design ideas for PPM modulation systems, and this paper will explain the principles of system modulation of PPM based on FPGA technology. Field Programmable Gate Array (FPGA) emerged in the 1980s. Due to their internal integration characteristics, distributed algorithmic structures can be easily implemented to process high-speed transmission signals. As a result, field programmable gate array technology (FPGA) is becoming more and more widely used in the field of communications. The design of PPMs based on FPGAs can combine both advantages and demonstrate the performance of PPM modulation systems more clearly.

PPM as a pulse modulation method, its basic structure can include protection time slot and multiple information time slots [16]. PPM includes LPPM, DPPM, MPPM, LPPM is single pulse position modulation, DPPM is differential pulse position modulation, MPPM is multi-pulse position modulation, this paper will discuss the LPPM, DPPM and MPPM modulation methods will be discussed separately in this paper [16]. For DPPM, it is a differential modulation based on LPPM, and in this paper a differential pulse position modulation with a variable number of time slots is used. For MPPM, the number of pulses in a frame is not 1, so it is multi-pulse position modulation [18]. For the sake of convenience, the protected time slots in the PPM frame structure are not considered for the time being. This 4-PPM structure is shown below, with mapping relationships 00->1000, 01->0100, 10->0010, 11->0001, and pulses occurring in time slot 1, time slot 2, time slot 3, and time slot 4, respectively, as shown in Fig.1 [19].

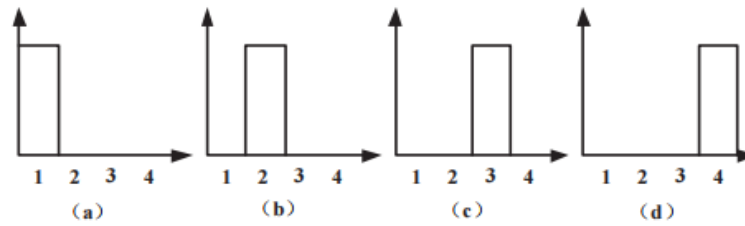

Fig 1. 4-PPM modulation structure [19]

Similarly, for the 16-PPM frame structure, there are corresponding mapping relations 0000->1000000000000000, 0001->0100000000000000 The pulses appear on the left-hand side, and the value k is the decimal value of the four binary digits. For DPPM, (DPPM is 4-DPPM in this paper), DPPM is an improved modulation based on PPM, and its mapping relationship with PPM is shown in Table 1. The coding scheme of MPPM varies with M and k , which is more complicated and will be discussed and analyzed in the following Tab.1.

Table 1. 4-Ppm And 4-Dppm Mapping Relationships [20]

Letter Source Bits	4-PPM coded signal	4-DPPM coded signal
00	1000	1
01	0100	01
10	0010	001
11	0001	0001

2.2. Modulation Principle of PPM

As PPM is a time slot-based pulse phase modulation, the choice of the operating clock is particularly important, which is inseparable from the application of frequency dividers. As a basic circuit in digital logic circuits, the frequency divider obtains the required frequency by dividing a given frequency [21]. Since the number of bit intervals in the PPM M is not 1, counting is required, which makes the use of counters indispensable. Counters are also an important module in digital logic circuits. Depending on the value of M , the number of bits in the counter varies. A comparator is also indispensable, by means of which the position of the pulse appears can be obtained. By processing the modulated signal, the narrow pulse shaper can shorten the pulse time width and increase the data transmission rate [22]. Usually the modulation of the PPM consists of the four modules mentioned above, namely the divider, the counter, the comparator and the narrow pulse generator.

According to the previous section, 4-PPM and 16-PPM have their corresponding mapping relations, which are then related to the modulation system of PPM. Taking the 4-PPM modulation system as an example, its principle is shown in Fig.2.

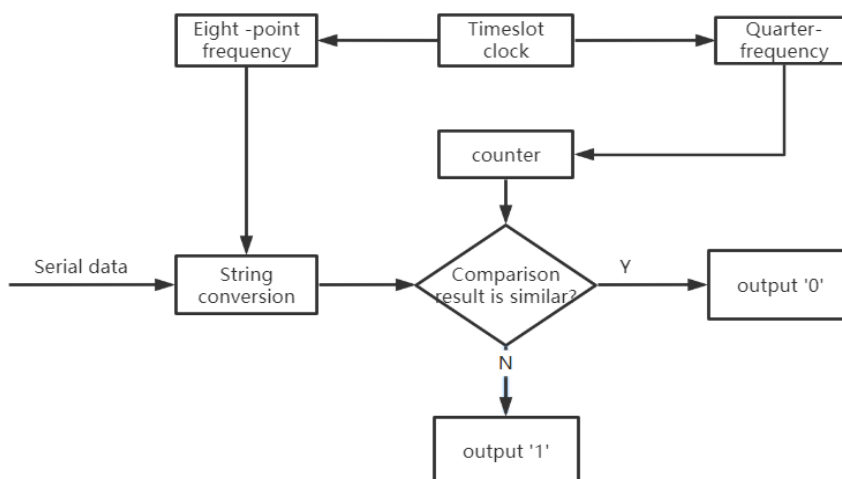

Fig 2. 4-PPM modulation schematic [23]

This 4-PPM system time slot clock is transmitted in two ways after a quadrature and an octave operation to provide the operating clocks for the serial and parallel modules and the counter modules, respectively. The serial data is converted to serial-parallel in the serial-parallel module, i.e., the binary encoding of the input bit stream is completed [24]. The comparator compares the output of the counter with the serial-parallel converted output, i.e., the parallel data. If the number of decimal bits corresponding to a set of binary data is equal to that of the counter, a high-level pulse signal is output at the corresponding information time slot position; otherwise, a low-level signal is output. At this point, the high- and low-level output determination has been completed and two more modules are required to complete the full modulation process. the narrow pulse generator module and the shaping output module, respectively [16]. For the 16-PPM, similarly to the 4-PPM described above, a series-parallel conversion and frequency division is required, with each two bits being output in parallel and compared with the counter output, i.e. the time slot statistics, to complete the low and high-level judgment. The main structure is composed of a frequency divider, a series-parallel converter, a counter and a comparator [25]. The special feature of this DPPM modulation method is that the data obtained after the series-parallel conversion is stored in RAM and compared with the data stored in ram to calculate the pulse position and finally the DPPM pulse is output [20]. The above is the general modulation flow of 4-PPM modulation and DPPM. These three PPM-related modulation systems are discussed in depth below based on the abovementioned principles.

3. Design of Three PPM Modulation Systems

3.1. 4-PPM Modulation

The 4 in 4-PPM here means that there is only one pulse in four-time slots and the modulator should transmit $\log_2 4$ bit data i.e., 2 bits of data in one frame of time. The protected time slots are not counted in the frame structure for convenience. This means that there are only 4 transmission time slots in a frame. The pulses in different positions also correspond to different data, which is the basic principle of pulse position modulation. This is the basic principle of pulse position modulation. At this point, it is particularly important to determine the position of the time slot where the pulses are generated. A counter can carry out this process to count and thus output pulses at different time slot positions [23]. The process is based on the time slot clock period, which is divided into frequencies. Then the timing process is equated to a counting process, where the count is performed every time the rising edge of the clock is reached. Eventually, when the count value is compared with the binary input serial and converted data, the count value is the position of the pulse in the time slot when the two are equal. Because of the 4-PPM modulation, the upper limit of the count is set to 4. Whenever the count reaches 4, it is cleared and starts again for the next cycle. So, this requires a quadrature clock, and when the fourth rising edge of the clock is reached, a new round of counting is started. Furthermore, since 4-PPM modulation transmits 2 bits of data in one frame time. In order to maintain consistency with the counter clock reference, the transmitted binary bit stream needs to be serially converted and the system clock octets as the clock for the serial conversion. After adjusting the clock, the 2-bit binary data is compared with the counter value utilizing a comparator, which outputs a 1 in the corresponding bit if equal or a 0 if unequal. Thus, the pulse position modulation is basically complete, and a narrow pulse generator then completes the 4-PPM modulation.

The FPGA implementation for 4-PPM is based on the hard-wired logic characteristics of FPGAs, and the Verilog coding of the individual functional modules is used to implement [16]. The top-level design of PPM modulation is to stitch all the modules of the modulation part together to finally implement the modulation function [23], as shown in Fig.3. the input data of the PPM modulation system is InDat (0x55, 0x79, 0xd8, 0xd8, 0x55, 0x79).

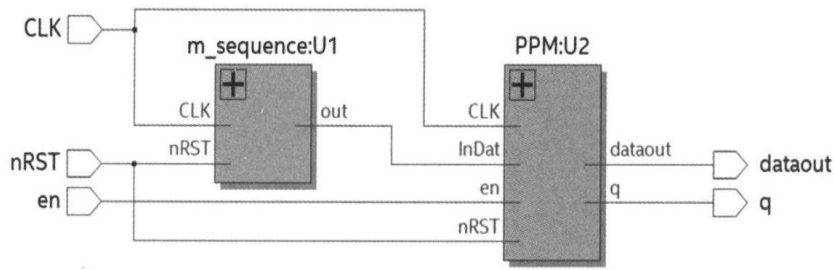

Fig 3. 4-PPM modulation RTL diagram [23]

To implement a 4-PPM demodulation system, frame synchronization is first performed by inserting a frame header and a frame tail on both sides of a frame as the start and end bits. Only when the frame header is detected does the process of determining the position occupied by the pulse in this frame begin, and then demodulation is performed. Demodulation is the inverse modulation process and its Verilog flowchart is shown in Fig.4.

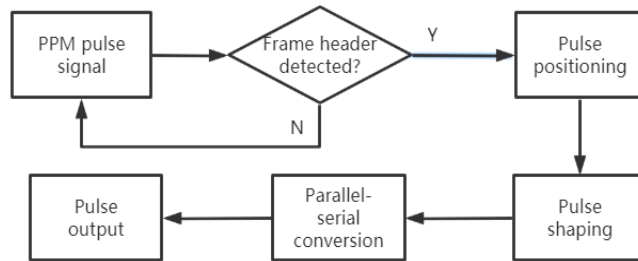

Fig 4. 4-PPM demodulation flow chart [23]

For the FPGA implementation of the 4-PPM demodulation system, the test file is first added to the project and the test file reads the data input of the demodulation system. After modeling in modelsim, the results obtained from the demodulation system are shown in Fig.5. It can be seen that the data obtained from demodulation are 0x55, 0x79, 0xd8, 0xd8, 0x55, 0x79, which are consistent with the input data. The whole modulation and demodulation system can be implemented properly, and the 4-PPM system is verified.

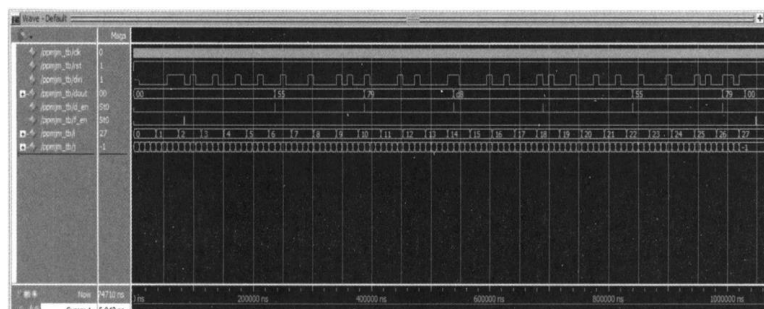

Fig 5. Plot of 4-PPM modulation simulation results [23]

3.2. DPPM Modulation

DPPM is a modulation method based on and improved from PPM modulation. The DPPM modulation described in this paper has variable time slots. The minimum number of time slots is 1 and the maximum is 4. The mapping relationship has already been described in the previous section, so it will not be repeated. For DPPM modulation, similar to the 4-PPM described previously, the same frequency divider, counter, serial and parallel conversion and RAM internal memory are required, as shown in Fig.6. The RAM memory module has two address signals. a write address signal and a read address signal. As an important module in the modem system, the read/write process is mainly as follows. Firstly, the read/write address is reset to 0 and the read enables signal is cleared to zero. Only write operations can be performed to the RAM staging, thus avoiding reading out some

previously stored error data. This avoids reading out some previously stored error data and transmitting error messages.

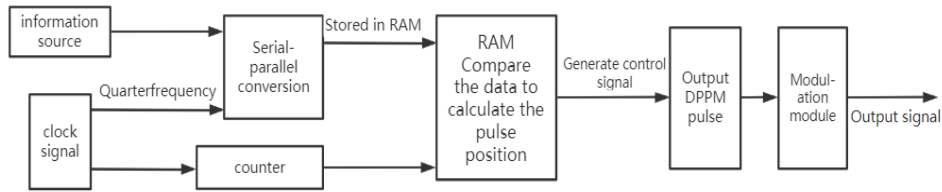

Fig 6. DPPM modulation hardware block diagram [20]

The demodulation block diagram of DPPM is shown in Fig.7. The demodulation idea is similar to that of 4-PPM, which also requires storing the photoelectrically converted signal in RAM. In order to control the clock synchronization, the frame synchronization signal needs to be resolved and the position of the pulses determined together with the generated control signal, and then parallel-serial conversion is performed to finally obtain the demodulated output signal. Looking at the modulated code, each segment of the transmit pulse is immediately followed by a low segment. The low level duration ends whenever the write stage RAM reaches half full. The end of the low level duration is followed by a segment of information, which varies according to the pulse position. In this paper, the low-level duration is equated to the frame synchronization header inserted into each transmit signal, thus omitting the design step of the frame synchronization header and making the demodulation process relatively simple.

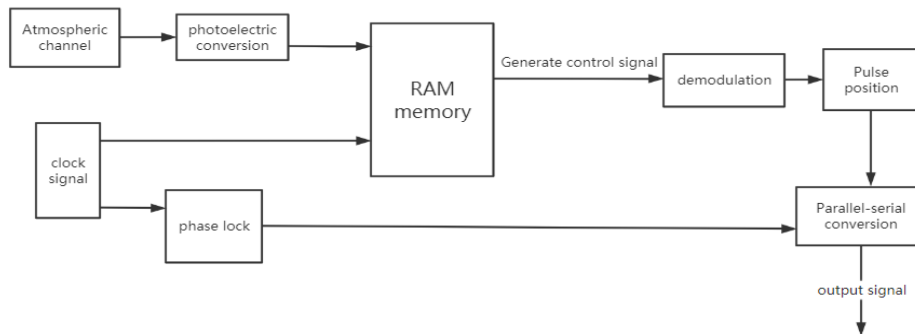

Fig 7. DPPM demodulation hardware block diagram [20]

3.3. MPPM Modulation

Multi-pulse position modulation (MPPM), which is based on the PPM concept, may generate multiple pulses in one frame time, which is the most significant difference between PPM and DPPM. The standard form of MPPM is (M, K) MPPM. M stands for the number of transmission time slots in one frame time and k stands for the number of pulses in one frame time [26]. Since pulsed lasers have a minimum repetition period, a protection period is added after each pulse. In addition, a frame synchronization header is added at the beginning of each information frame in order to synchronize the clock between the encoder and the decoder. The frame structure is shown in Fig.7.

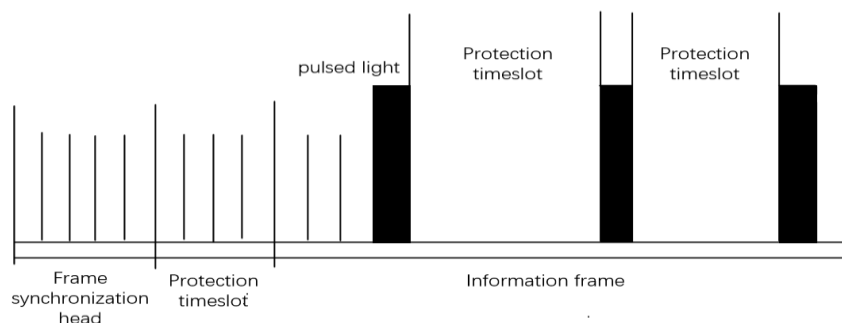

Fig 8. (6,3) MPPM symbol structure with protected time slots [26]

For the demodulation of MPPM, which is also the decoding process, it first needs to detect the frame synchronization header to determine the start of a frame, and then compare it with the relationship in Table 3 to correspond the 32bit (6,3) MPPM symbol back to the 4bit binary data, thus completing the decoding. Its specific modulation and demodulation process for FPGA is based on the 4-PPM modulation and demodulation system. It specifically requires a divider module, coding module, decoding module, parallel-serial conversion module, etc. It is similar to the PPM and DPPM introduced in the previous section, so it will not be repeated here.

3.4. Contrast

Table 4. Comparison Of The Parameters Of The Three Ppm Modulation Methods

Comparative parameters	L-PPM	L-DPPM	(M, k) MPPM
Number of code group bits (all without considering frame synchronization headers, protection time slots)	Fixed L bit (1 bit '1', L-1 bit '0')	variable number of digits (a string of variable digits '0' plus a '1')	The number of digits is $\lfloor \log_2 C_M^k \rfloor$
Whether synchronized clocks are required [27]	A code group synchronization clock is required to determine the start and end of a code group	No code-group synchronization clock required as its code-group is not fixed	A code group synchronization clock is required to determine the start and end of a code group
Application Scenarios	Low power mode/low bit rate mode	High noise immunity or ISI mode / high power	High data rate/band with efficient/non-uniform data rate mode
Presence of symbolic redundancy	Non-existent	Non-existent	exists. For example. (4,2) MPPM can provide a total of 6 symbols, but only 4 of them are selected for coded modulation.

In conclusion, as in Tab.4 the three PPM modulation methods, L-PPM and MPPM both have a fixed number of bits and also require synchronous clocks if the parameters are determined, while DPPM has an irregular number of bits and therefore does not require a code-group synchronous clock. symbol redundancy exists for MPPM, while the other two have no redundancy. Different PPM modulation methods are chosen for different application scenarios.

4. Conclusion

This paper presents a detailed introduction and comparison of the three pulse position modulation principles and analyses and verifies the three pulse position modulation systems based on FPGA technology. Although the three PPM modulations are based on similar principles, they differ in the specific coding mapping, the structure of the unit frame, the modulation and demodulation system module composition, application scenarios and characteristics. Therefore, in practical communication

application scenarios, the specific PPM method should be selected based on the modulation method's performance and the actual system requirements. Due to the feature that PPM only requires modulation of the pulse position, the PPM modulation system is built with low complexity and can transmit information with low power and high efficiency, so PPM is widely used in indoor computer Infrared communication PPM modulation also has a broad application prospect, gradually broadening from traditional optical communication and mobile communication to long-distance communication such as deep sea communication and satellite communication. In the future, PPM modulation technology deserves more research and exploration.

References

- [1] J.Pierce“Optical channels. Practical limits with photon counting,” *IEEE Transactions on Communications*, vol. 26, no. 12, pp. 1819–1821, 1978.
- [2] G. Prati and R. Gagliardi, “Block encoding and decoding for the optical PPM channel (CORRESP.),” *IEEE Transactions on Information Theory*, vol. 28, no. 1, pp. 100–105, 1982.
- [3] J. J. O'Reilly and Wang Yichao, “Line code design for Digital Pulse-position modulation,” *IEE Proceedings F Communications, Radar and Signal Processing*, vol. 132, no. 6, p. 441, 1985.
- [4] R. Gagliardi, J. Robbins, and H. Taylor, “Acquisition sequences in PPM Communications (Corresp.),” *IEEE Transactions on Information Theory*, vol. 33, no. 5, pp. 738–744, 1987.
- [5] R. A. Cryan, R. T. Unwin, A. J. Massarella, M. J. Sibley, and I. Garrett, “A comparison of coherent digital PPM with PCM,” *European Transactions on Telecommunications*, vol. 3, no. 4, pp. 331–340, 1992.
- [6] D. C. M. Lee, J. M. Kahn, and M. D. Audeh, “Trellis-coded pulse-position modulation for Indoor Wireless Infrared Communications,” *IEEE Transactions on Communications*, vol. 45, no. 9, pp. 1080–1087, 1997.
- [7] B. C. Akdeniz, A. E. Pusane, and T. Tugcu, “Position-based modulation in Molecular Communications,” *Nano Communication Networks*, vol. 16, pp. 60–68, 2018.
- [8] F.Zhang, B.Xiao, J.Zhou, B.Li, P.Yuan. Performance analysis of optical space-time grid codes under different modulation methods[J]. *Communication Technology*, 2018, 051(001):37-40.
- [9] M. Biagi, N. B. Hassan, K. Werfli, T.-C. Bui, and Z. Ghassemlooy, “Analysis and demonstration of quasi trace orthogonal space time block coding for Visible Light Communications,” *IEEE Access*, vol. 8, pp. 77164–77170, 2020.
- [10] K. Sharma and S. K. Grewal, “Performance assessment of hybrid PPM–BPSK–sim based FSO communication system using time and wavelength diversity under variant atmospheric turbulence,” *Optical and Quantum Electronics*, vol. 52, no. 10, 2020.
- [11] D. Zou and S. Ma, “Satellite Navigation and communication integration based on correlation domain indefinite pulse position modulation signal,” *Wireless Communications and Mobile Computing*, vol. 2021, pp. 1–11, 2021.
- [12] B. Li, B. Li, X. Zhang, C. Wang, L. Zhang, and S. Tong, “Influence of cloud characteristics on PPM optical communication rate,” *IEEE Photonics Journal*, vol. 14, no. 1, pp. 1–7, 2022.
- [13] F.Wang, L.Qin, X.Hu, et al. Effect of foggy weather on the BER of LED optical communication system with chaotic PPM[J]. *Computer Simulation*, 2022(001):039.
- [14] Z. Dou, X. Sha, Y. Wang, and D. Tian, “LDPC-coded optical PPM communication system over the atmosphere turbulence channels,” *The 2010 IEEE International Conference on Information and Automation*, 2010.
- [15] X. Ke and K. Dong, “Modulation, demodulation, and coding,” *Optical Wireless Communication*, pp. 81–147, 2022.
- [16] J.Ma Design and implementation of FPGA-based PPM system[J]. *Electronic Products World*, 2010(10):3.
- [17] T.Li, W.Yuan, M.Yi, and H.Zhou, “Time jitter effects on bit error probability in Multi-pulse position modulation satellite optical communication,” *Acta Optica Sinica*, vol. 30, no. 1, pp. 26–30, 2010.
- [18] G.Cha, Research on modulation and demodulation techniques of multi-pulse position modulation[D]. Chongqing University of Posts and Telecommunications.

- [19] C. Yonga, Z. Yifanb, L. Yi, W. Xiao, and H. Jinrui, "Design of universal PPM modulation module for laser communication based on FPGA," *2020 IEEE 2nd International Conference on Civil Aviation Safety and Information Technology (ICCASIT)*, 2020.
- [20] M.Zhu, P.Tang, X.Tang, et al. FPGA implementation of DPPM modulation and demodulation technology for laser communication[J]. *Electronic Design Engineering*, 2011, 19(15):3.
- [21] H.Wang and H.Li, Design of FPGA-based equal duty cycle arbitrary integer frequency divider[J]. *Modern Electronic Technology*, 2005, 28(16):2.
- [22] J. Yang, J. Wang, and Q. Chen. Design and simulation of an underwater optical communication system based on PPM modulation[J]. *Computer and Digital Engineering*, 2018, 46(7):5.
- [23] H. Hou and H. Shi, Design of FPGA-based PPM modulation and demodulation system[J]. *Electronic Technology Applications*, 2021.
- [24] J.Duan and Z.Huang, CPLD/FPGA-based digital communication system modeling and design [M]. *Electronic Industry Press*, 2004.
- [25] Y.Yang Comparative analysis of two kinds of PPM modulation based on FPGA[J]. *Journal of Chengdu Institute of Technology*, 2019, 22(2):5.
- [26] L.Qin, Y.Du, and X.Ke, et al. Implementation of MPPM compiled code system with three pulses in atmospheric laser communication[J]. *Semiconductor Electricity*, 2008, 29(3):403-406+433.
- [27] J.Wang and Z.Zhang, PPM modulation in wireless optical communication[J]. *Telecommunications Technology*, 2000, 40(5):81-84.