

Design of a Detachable Surface Garbage Cleaning Robot Suitable for Small Water Areas

Wencheng Wang^{1,2}, Quandi Wu³, Pengcheng Zhang^{1,2}, Tianci Liu¹

¹ Department of Mechanical Engineering, Hebei University of Water Resources and Electric Engineering, Cangzhou, Hebei 061000, China

² Hebei Industrial Manipulator Control and Reliability Technology Innovation Center, Cangzhou, Hebei 061000, China

³ College of Mechanical and Electrical Engineering, Hebei Normal University of Science & Technology, Qinhuangdao, Hebei 066000, China

Abstract: Surface garbage in small water bodies poses a severe threat to the safety of residents' water usage. Focusing on the characteristics of surface garbage in small water bodies, a robot capable of collecting light floating debris and animal carcasses have been designed. This paper accomplishes the design process of a detachable structure surface garbage cleaning robot suitable for collecting floating garbage in small water areas, the calculation process of the draft and travel resistance, and the selection and calculation process of the propulsion device. Furthermore, the robot has been fabricated, and it is capable of cleaning various types of waste, thereby providing a guiding document for the structural design of surface garbage cleaning equipment.

Keywords: Garbage Cleaning Robot; Garbage Collection Device; Structural Design; Small Water Bodies.

1. Introduction

In recent years, the problem of garbage pollution in China's waters has become increasingly severe. The amount of floating garbage in rivers, lakes, and reservoirs is on the rise. Over time, this garbage first pollutes the ecological environment of the water and then threatens the health of nearby residents. At present, the methods used to clean up water garbage mainly include mechanical and manual cleaning. Mechanical cleaning mostly uses surface garbage cleaning boats which, while efficient and effective for large quantities of garbage, are not capable of dealing with scattered debris, for which manual cleaning is typically used. However, manual cleaning requires a significant amount of labor and resources and carries certain safety risks. The cleaning of floating garbage in small water bodies such as scenic spot lakes and campus lakes is mainly done manually, which is inefficient, costly, and unsafe. Surface garbage cleaning boats on the market are designed for concentrated garbage in large areas, with their high cost, complex structure, and large size being unsuitable for small water bodies such as urban lakes and rivers.

Research on surface garbage cleaning devices started early in developed countries, where the technology is mature, multiple series have been developed, and it has become a major means of protecting urban water environments in these countries. The Trash Cat series of surface garbage cleaning devices developed by the U.S. company UMI are catamarans equipped with dual propellers and are mainly used to clean up surface garbage[1-3]. Italy's GLOBECO company developed the Dolphin multifunctional ecological cleaning boat, which serves functions such as oil spill clean-up, collection of large debris, collection of chemical spills, water body oxygenation treatment, and detection and firefighting[4]. The SOLID series of cleaning boats offered by Spain's Beach-Trollers company use a monohull mainly for the salvage of floating and suspended solid garbage [5-6]. China's "Qing Piao No.1" uses a catamaran, mainly for cleaning up a large amount of floating debris on the surface of the Three Gorges Reservoir area, ensuring the safe operation of power stations and the cleanliness of the reservoir surface [7].

Based on the current research at home and abroad, it has been discovered that existing water surface garbage cleaning equipment mostly focuses on large water area garbage cleaning, with high automation, but their large size and high cost make them unsuitable for garbage cleaning in small water areas such as city lakes and rivers. This paper proposes a detachable small water area automatic garbage cleaning robot to solve the above problem.

2. Design Requirements

The portable automatic surface garbage cleaning robot for small water bodies (hereinafter referred to as the robot) requires portability. It is designed to be a detachable structure that is easy to disassemble. It is required to collect floating objects (individual mass less than 5 kg, such as weeds, leaves, garbage bags, etc.) and heavy floating objects (individual mass of about 10 kg, such as floating carcasses of cats and dogs) efficiently. The robot must have a surface sailing speed of no less than 1m/s and a continuous endurance time of no less than 3 hours.

3. Determination of the Main Structure for the Surface Garbage Cleaning Robot

The main structure of the designed robot effectively consists of a light floating garbage collection device, a heavy floating garbage collection device, and a control system assembly mounted on the hull. During the design process, it is necessary to determine the structures of the hull, the light floating garbage collection device, and the heavy floating garbage collection device, based on the characteristics of small water areas and the collection characteristics of floating garbage, to finalize the main structure of the robot.

3.1. Determination of the Hull Structure

The robot designed for operation in small water areas has the collection device installed on the hull, and the installation of the collection device has a great impact on the stability of the hull during surface navigation. Currently, there are two types of small hull structures to choose from: monohull and

catamaran.

The monohull structure, as shown in Figure 1(a), is basically molded in one piece through injection molding and, after retrofitting, the floating garbage collection device is integrated onto the hull to realize the purpose of floating garbage collection. However, the monohull hull structure is complex, consumes a large amount of energy, and has a large impact on the stability of the hull operation, which cannot meet the design requirements of this paper.



(a) The monohull structure

(b) The catamaran structure

Figure 1. illustrates the hull structure

The catamaran structure connects two single-body pontoons through connectors, as shown in Figure 1(b), with a large gap between the single bodies. The water surface garbage cleaning device of the catamaran type can be installed in the middle position of the hull. During operation, floating garbage can gather within the range of the water surface garbage cleaning device through the gap between the two single-body pontoons. This device does not need to lift garbage out of the water; that is, the floating garbage collection device matched with the catamaran hull can simply

realize the function of gathering and collecting floating objects, which is structurally simple, with low energy consumption, and provides relatively stable and reliable hull motion. Through modular design, the catamaran hull can be designed to be detachable to meet portability requirements.

Based on the above analysis, the main body of the robot designed in this paper adopts a catamaran structure.

3.2. Design of the Floating Garbage Collection Device Structure

The common types of surface garbage collection devices primarily include conveyor belt type, bucket type, and rotating type collection devices.

For the catamaran structure of the robot designed in this paper, all three of the aforementioned mechanisms, whether driven by an electric motor or hydraulic power, require an independent power source, resulting in a complex structure. When cleaning surface garbage, these devices must lift the floating waste out of the water and bear its entire weight, necessitating a significant energy supply, which obviously places higher demands on the robot's endurance capability.

To address the issues of complexity and high energy consumption of existing surface garbage collection devices, the TRIZ innovation method was utilized to analyze the characteristics of the double-hulled structure of the robot body and the floating nature of surface garbage. By applying the principle of separation, the gravity bearing function and transport function of the surface garbage are separated. This approach entails modifying the structure of existing garbage lifting devices to function as garbage collection devices instead, using water buoyancy to neutralize the effect of gravity; and utilizing the propulsive force of the garbage collection device to transport the surface garbage. This significantly reduces the complexity of the structure and energy loss. The integrated robot body structure with a floating garbage collection device is illustrated in Figure 2.

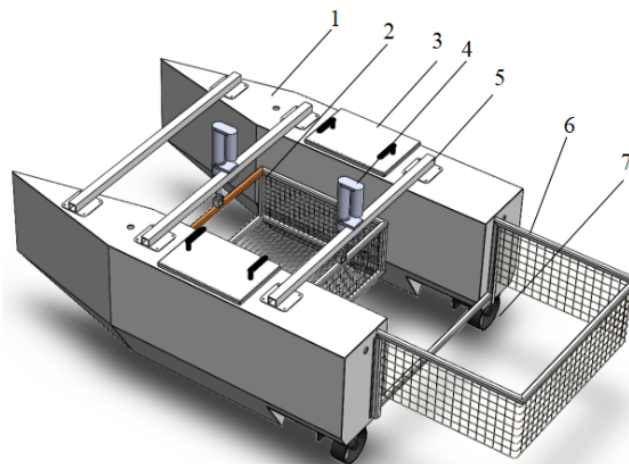

Figure 2. Schematic Diagram of the Surface Garbage Cleaning Robot Structure
 1- Hull body 2- Heavy floating garbage collection basket 3- Battery box cover
 4- Electric push rod 5- Connector 6- Light floating garbage collection basket
 7- Propeller

When the robot cleans up small, light floating debris weighing less than 0.5 kg (such as branches, leaves, grass, garbage bags, etc.), the collection basket for heavy floating objects is raised above the water surface by electric push rods. The light floating objects enter the basket located at the rear of the boat through the gap between the hulls. This basket for

light floating objects only restricts and pushes the light floating objects, enabling continued garbage collection.

When cleaning up heavy floating objects weighing around 10 kg with larger volumes (such as carcasses of small animals like cats and dogs), the collection basket for heavy floating objects is lowered below the water surface by electric push

rods. The heavy floating objects float into the basket through the gap between the hulls and are confined within the basket, preventing them from floating away. The robot then drags the heavy floating objects back to the shore, where workers lift them out of the water.

3.3. Robot Main Body Portability Design

To meet the portability requirements of the surface garbage cleaning robot, its main body is divided into four modules, as

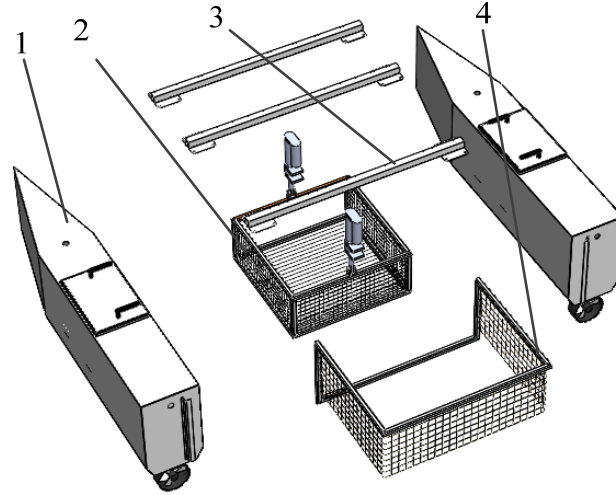

Figure 3. Robot Main Body Disassembled Explosion View
1-Hull Single Module 2-Heavy Floating Garbage Collection Module
3-Connecting Parts 4-Light Floating Garbage Collection Module

From Figure 3, it can be seen that the two hull single modules are connected by three connecting parts using bolts, butterfly bolts are used for ease of disassembly; heavy floating garbage collection devices use cotter pins to fix the two electric push rods to the connecting parts, and the light floating garbage collection devices use the aluminum alloy profile of the collection basket to fit into the slide groove at the end of the hull single module, fixing it to the rear of the hull.

4. Propulsion Device Selection

The surface garbage cleaning robot designed adopts a catamaran structure and uses two propellers as the propulsion devices to achieve the robot's forward, reverse, and turning functions. The design requirement is that the speed of the robot under the propellers' thrust should not be less than 1m/s.

To obtain the propulsive force needed by the propellers to meet the design requirements, it is necessary to first determine unknown parameters such as the mass of the hull, resistance during travel, and acceleration.

4.1. Robot Mass

Using the Solidworks 3D software, a model of the main body of the robot was created as shown in Figure 2. The main materials for the hull, connecting parts, collection baskets for heavy and light floating garbage are all made of aluminum alloy 6061. Using the mass properties tool in Solidworks, the mass of each component can be measured, as listed in Table 1. The total mass of the robot's main body (hull, connecting parts, collection baskets for heavy and light floating garbage, propeller, push rods, and battery covers) is 34.3 kg. In terms of energy, it is equipped with two 12V/60AH lithium batteries, which weigh approximately 12 kg. The camera, microcontroller, cables, and other accessories weigh

shown in Figure 3: the hull single module, heavy floating garbage collection module, light floating garbage collection module, and connecting parts.

The hull single module includes: a single float, one lithium battery, a battery cover, and one propeller; the heavy floating garbage collection module includes: a collection basket for heavy floating objects and two electric push rods; the light floating garbage collection module includes a collection basket for light floating garbage.

approximately 2.5 kg, making the total weight of the designed robot about 48.8 kg. This meets the project design requirement of a total mass not exceeding 150 kg.

4.2. Calculation of Displacement and Maximum Draft

According to Archimedes' principle, an object immersed in a fluid experiences an upward buoyant force F_b equal to the weight of the fluid displaced G_v , by the object.

The formula is expressed as follows:

$$F_b = G_v \quad (1)$$

Where:

$$F_b = \rho_w \cdot g \cdot V_d \quad (2)$$

Substituting equation (2) into equation (1), it can be obtained:

$$V_d = \frac{F_b}{\rho_w g} = \frac{mg}{\rho_w g} = \frac{48.8 \times 9.8}{1 \times 10^3 \times 9.8} = 0.0485 \text{m}^3$$

When the robot's body floats on water, the underwater part of the body is illustrated in Figure 4, which includes three sections: the bottom pyramid at the head, the bottom prism, and the rectangular prism on top of the prism. The sum of the volumes of these three sections equals the displacement volume, which can be calculated as:

$$V_d = 2(V_1 + V_2 + V_3) \\ = 2 \times \left[\frac{1}{3} \times \frac{1}{2} a H_1 L_1 + \frac{1}{2} a H_1 L_2 - \frac{1}{2} \frac{H_2}{H_1} a H_2 L_3 + a(L_1 + L_2)(H - H_1) \right] \quad (3)$$

By inputting the design dimensions: $a=230$ mm, $L_1=500$ mm, $L_2=900$ mm, $L_3=300$ mm, $H_1=200$ mm, $H_2=150$ mm into equation (3), we find $H=211$ mm. The designed robot body height is 530 mm, meeting the design requirements.

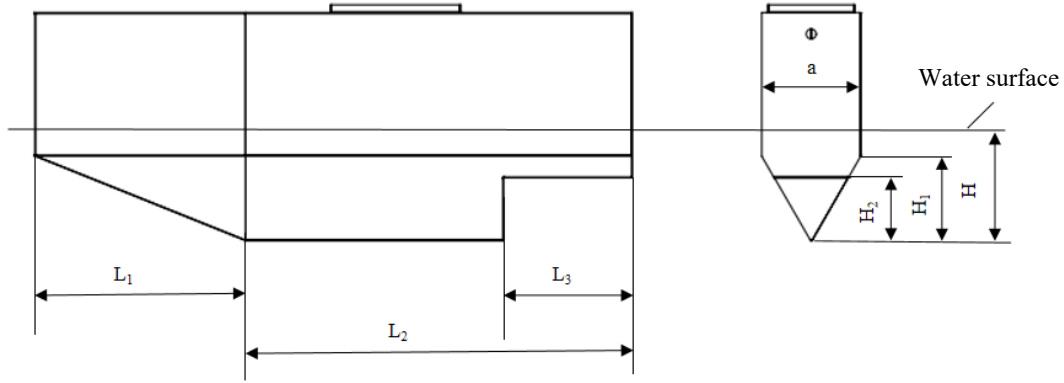

Figure 4. Diagram of the underwater section of the robot

4.3. Calculation of the Robot's Resistance

In reality, the robot's body is a catamaran. During movement, the resistance mainly includes: fluid resistance and air resistance. Fluid resistance mainly consists of: still water resistance and wave-making resistance. Still water resistance is further divided into bare-hull resistance and appendage resistance. Bare-hull resistance includes: wave-making resistance and frictional resistance.

Wave-making resistance is the additional resistance a ship encounters sailing in wind and waves compared to still water. Since the designed water surface garbage cleaning robot operates in relatively calm waters, wave-making resistance is not considered. Additionally, aside from the propellers, there are no other appendages on the body, so appendage resistance is also not considered.

According to Bernoulli's equation, as water flows past the hull during forward movement, the change in flow speed along the length of the ship causes changes in water level, creating vibrations and waves. The resistance caused by the change in pressure distribution due to wave creation is known as wave-making resistance. The nature of wave-making resistance is different from that of viscous resistance and pressure-difference resistance. Wave-making resistance is not related to the viscosity of the fluid but depends on the shape of the ship and its speed. Considering practical circumstances, since the designed cleaning ship has a small body and slow running speed, wave-making resistance is not considered.

Therefore, the main resistances for the designed water surface garbage cleaning robot are: frictional resistance and air resistance.

1. Calculation of Frictional Resistance

The cause of frictional resistance: Due to the viscosity of the fluid, water particles moving along the surface of the hull create a force that hinders the motion of the ship.

(a) Calculation of the ship's block coefficient C_B

$$C_B = \frac{\Delta}{L \cdot B \cdot T} = \frac{0.0485}{1.4 \times 0.46 \times 0.211} \approx 0.36 \quad (4)$$

Where: Δ is the ship's displacement volume in cubic meters;
 L is the length of the waterline at that displacement volume in meters;

B is the breadth of the ship in meters;

T is the draft of the ship at that displacement volume in meters.

(b) Calculation of the Wetted Surface Area S

$$\begin{aligned} S &= L[2T + 1.37(C_B - 0.274)B] \\ &= 1.4 \times [2 \times 0.211 + 1.37 \times (0.36 - 0.274) \times 0.46] \\ &= 0.667 \text{ m}^2 \end{aligned} \quad (5)$$

(c) Calculation of the Reynolds Number Re

Choosing a standard temperature $t=15^\circ\text{C}$, the kinematic viscosity of water at this temperature is $\nu=1.18831 \times 10^{-6} \text{ m}^2/\text{s}$, with the ship's speed relative to the water flow $v=1.5 \text{ m/s}$.

$$Re = \frac{vL}{\nu} = \frac{1.5 \times 1.4}{1.1883 \times 10^{-6}} \approx 1.767 \times 10^6 \quad (6)$$

(d) Frictional Resistance Coefficient C_f

$$C_f = \frac{0.075}{(\lg Re - 2)^2} = \frac{0.075}{(\lg 1.767 - 2)^2} = 0.0244 \quad (7)$$

(e) Standard Surface Roughness Compensation Coefficient ΔC_f

$$\Delta C_f = 0.0004$$

(f) Calculation of the Ship's Frictional Resistance R_f

$$\begin{aligned} R_f &= (C_f + \Delta C_f) \frac{1}{2} \rho v^2 S \\ &= (0.0244 + 0.0004) \times \frac{1}{2} \times 1000 \times (1.5)^2 \times 0.667 \\ &= 18.61 \text{ N} \end{aligned} \quad (8)$$

2. Calculation of Air Resistance

The part of the robot above water will experience air resistance. Air resistance is a reactive force formed by the air against the advancing ship, calculated as follows:

$$F_w = \frac{1}{2} A C_w v^2 \quad (9)$$

Where: v is the relative speed of the body against the air in m/s , assuming the working environment has wind speeds of Beaufort scale 5 or below, taking wind speed as 10 m/s . According to design requirements, the body's travel speed should not be less than 1 m/s , so the robot's relative speed against the air is 11 m/s ;

A is the cross-sectional area of the ship's part above water in m^2 , measured as: $A \approx 0.21 \text{ m}^2$.

C_w is the wind resistance coefficient, generally between 0.3 (good) and 0.6 (poor), with a value of 0.6 chosen for this design.

By substituting the values into equation (9), it can be obtained:

$$F_w = \frac{1}{2} \times 0.21 \times 0.6 \times 11^2 = 7.623 \text{ N}$$

In summary, the total resistance encountered by the water

surface garbage cleaning robot during its operation is:

$$F_R = R_f + F_w = 26.23 \text{ N}$$

4.4. Calculation and Selection of Parameters for the Robot's Propeller

Considering the artificial lakes in cities have still water with a flow speed of 0m/s and water channels typically do not exceed 0.5m/s, the design requirement is for the robot to have a sailing speed of no less than 1m/s. It is known that when the robot sails against the water flow, its relative speed against the water flow should not be less than 1.5m/s.

1. Calculation of Motion during Acceleration

Assuming the robot's acceleration $a=0.5 \text{ m/s}^2$, the total weight of the robot $m=48.8 \text{ kg}$, and the total resistance during movement $F_R=26.23\text{N}$

Traction Force F : $F=ma+F_R=50.63 \text{ N}$

Power required during acceleration: $P=Fv=75.95 \text{ W}$

Calculation of Motion during Steady Running

Power: $P=F_R v$, $P=39.35\text{W}$

To ensure the robot operates normally, the power should be 5~6 times higher than the acceleration power. Since the propulsion is provided by two propellers working simultaneously, the power needed for the propeller selection should be greater than 220 W. When the ship is moving, the propulsive force provided by the propellers should be greater than the acceleration thrust, so the propeller thrust selected should be greater than 26N.

Considering all factors, the Frostless Shaftless Underwater Propulsor is chosen as the propulsion device, as shown in Figure 5. This propulsor has a built-in motor with a power of 500W, providing 35N of thrust at a working voltage of 12V. The battery requires a voltage of 12V and a continuous discharge current of no less than 15A.



Figure 5. Frostless Shaftless Underwater Propulsor

5. Battery Selection

The energy consumption of the water surface garbage cleaning robot designed is mainly from the two propellers, which require 12V voltage and a continuous discharge current of no less than 15A. Additionally, the push rods require an input voltage of 12V, with a current of 2A; the processor for video processing requires an input voltage of 12V, with an input current of 2A; the remote control wireless transmission device requires an input voltage of 12V, with an input current of 0.5A. The design requires the robot to have a continuous endurance time of no less than 3 hours. When selecting two 12V/60AH lithium batteries, the endurance time is approximately 3.3 hours, meeting the design requirements.

After the structural design of the water surface garbage automatic cleaning robot is completed, it is the responsibility of the manufacturer to process and produce it. The completed water surface garbage automatic cleaning robot entity structure is shown in Figure 6.

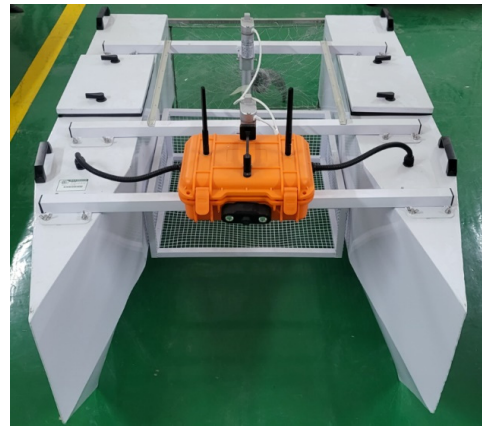

Figure 6. Automatic Garbage Cleaning Robot Entity

6. Conclusion

This paper mainly introduces the design process of a detachable structure surface garbage cleaning robot suitable for collecting floating garbage in small water areas, the calculation process of the draft and travel resistance, and the selection and calculation process of the propulsion device. Furthermore, the robot has been fabricated, and it is capable of cleaning various types of waste, including light floating debris and floating carcasses.

Acknowledgments

Funded by Science Research Project of Hebei Education Department (ZD2021329).

References

- [1] Desjoyaux pierre louis, Hoan tuan dung, Saccucci jean paul. Swimming pool basin water filtering device, has floating assembly connected to remote control device that is presented in form of vacuum cleaning robot and ensuring displacement of assembly at surface of water in concomitant manner[P]: FR2890992, 2007-03-23.
- [2] O, Hyeong Sun, Kwon, Jung Han, Lee, Chan Haeng, Kim, Sang Jun. Underwater robot for cleaning hull surface using water depth information [P]: KR20150022540, 2015-03-04.
- [3] Jin-gang, Jiang, Yong-de, Zhang, Shu, Zhang. Implementation of glass-curtain-wall cleaning robot driven by double flexible rope [J]. The Industrial Robot, 2014, 41(5): 187-192.
- [4] Ahmet Uner, Faruk Yilmaz. Efficiency of Laundry Polymers Containing Liquid Detergents for Hard Surface Cleaning[J]. Journal of Surfactants and Detergents, 2015, 18(2): 57-63.
- [5] Ahmet Uner, Faruk Yilmaz. Efficiency of Laundry Polymers Containing Liquid Detergents for Hard Surface Cleaning[J]. Journal of Surfactants and Detergents, 2015, 18(2): 97-103.
- [6] Subhrajit Bhattacharya, Soonkyum Kim, Hordur Heidarsson, Gaurav S. Sukhatme, Vijay Kumar. A topological approach to using cables to separate and manipulate sets of objects[J]. The International Journal of Robotics Research, 2015, 34(6): 144-148.
- [7] Bhattacharya Subhrajit, Kim Soonkyum, Heidarsson Hordur, Sukhatme Gaurav S., Kumar Vijay. A topological approach to using cables to separate and manipulate sets of objects[J]. The International Journal of Robotics Research, 2015, 34(6): 90-95.