

# The Application and Development Trend of New Chinese Style in Interior Design

Lianya Liu, Zhou Zhang, Mou Lv

Wuhan Textile University, Wuhan Hubei, 430073, China

**Abstract:** Objective It opens up a new way for the sustainable development of new Chinese style in interior design. Method By analyzing and comparing the origin, characteristics and development trend of the new Chinese style, this paper elaborates the historical position and development direction of the new Chinese style in interior design. Results Through the combination and innovation of modern fashion elements, the Chinese elements and styles in interior design are reborn. Conclusion It can provide reference for designers of new Chinese style home decoration.

**Keywords:** New Chinese Style; Interior Design; Trend of Development.

## 1. The Development and Origin of New Chinese Style

With the rapid development of China's economy and people's increasingly strong desire for a better material life, the home environment has become the most crucial and important emotional home in people's lives. In the 1920s, interior design was dominated by American, European, Romanesque and other design styles. At the same time, Chinese designers also began to reflect on local design. With the application of Chinese elements, it played a key role in promoting the national style. Among various interior designs, the new Chinese style has emerged as a powerful force, becoming the most popular and promising decoration style in interior design. It not only inherits the traditional Chinese culture and classical atmosphere, but also appropriately combines the development requirements and directions of modern interior design in accordance with local conditions, giving birth to a new Chinese style with Chinese elements and symbols.

### 1.1. The Historical Background of the Rise of New Chinese Style

The history of furniture design in China is long. Among them, the furniture of the Ming Dynasty (1368-1644) is a model of Chinese-style furniture. In today's new Chinese-style furniture or decoration styles, the shadow of Ming Dynasty furniture can be reflected everywhere. Due to the relatively developed handicrafts in the Ming Dynasty, furniture design was more applied to furniture materials and craftsmanship. For instance, rosewood was the main material, and mortise and tenon structures were used for support in craftsmanship (Figure 1). Since the Republic of China (1912-1949), with the transformation of the cultural movement, furniture design has undergone a complete subversion. Western furniture design was copied directly, but it was still Chinese artisans who completed the design. Therefore, although the furniture was European in style, it still retained some traditional Chinese elements to a greater or lesser extent. In contemporary times (1949-), furniture design has gradually shifted from meeting People's Daily life needs to spiritual needs along with the development of China's economy. Traditional Chinese elements have been valued and applied by people again. The emergence of new Chinese style can be

regarded as a transformation of traditional Chinese style. Its appearance and rise mark the revival and development of traditional Chinese cultural trends.



Figure 1. shows the official hat chair, a representative of Ming and Qing furniture

### 1.2. The Development and Evolution of New Chinese Style

With the improvement and enhancement of people's material living conditions, they have higher pursuits and yearnings for the home environment. Meanwhile, traditional Chinese culture and national imprints have led to the return of the new Chinese style in furniture design and interior design. This return is not a step-by-step restoration to traditional Chinese elements and styles. Instead, it is a new Chinese style with Chinese elements and implications that emerges based on people's functional and emotional needs and in combination with the rationality of Western design. It has undergone greater changes and developments in terms of materials and processes compared to before. It is no longer a single material or structure, but is designed and applied according to different environments, demands and functions, etc. For instance, symmetrical techniques are retained in terms of space and layout. The scope involved in materials and craftsmanship is broader (such as glass, stone, new types of fibers and light metals, etc.). Decorative elements are applied in products and functions, and more humanized multi-functional products are designed in combination with ergonomics. In terms of decorative color matching, colors with national characteristics are chosen, such as black, white and gray. It is further embellished with vibrant color schemes

such as gold and silver. The traditional Chinese style is continued in decorative accessories and ornaments, such as calligraphy and paintings, carpets, antiques, blue and white porcelain, etc.

### 1.3. The Differences between New Chinese Style and Chinese Style

Firstly, the new Chinese style has made significant innovations in material selection and technology, combining traditional craftsmanship with modern techniques. Besides its own practical functions, it also has aesthetic functions. Secondly, in terms of style, it is not simply creating new things by worshipping foreign things and discarding all traditional cultures. Instead, it takes the essence and discards the dross, fully demonstrating the inheritance of culture. Extract traditional and modern elements and apply them to the new Chinese style, making it not only meet the aesthetic requirements of contemporary people but also possess the cultural heritage of the Chinese nation. Finally, in terms of the temporal function, it is necessary to focus on the present and look to the world, meet the aesthetic standards of the general public, and make the new Chinese style known to the world.

The new Chinese style is an inheritance and development of the Chinese style, and an innovation on its basis. It not only has the traditional charm but also meets the needs of modern people. It conforms to the current trend and extends the traditional classical art to modern interior design.

## 2. Development Characteristics of New Chinese Style

New Chinese style has developed on the basis of inheriting traditional culture. It not only retains the style of traditional Chinese style but also innovates its fashion and trend in design, demonstrating a perfect integration of the classical artistic atmosphere of China and modern art design. Its characteristics are specifically manifested as:

### 2.1. Cultural Inheritance and Promotion



Figure 2. New Chinese-style calligraphy and paintings, antiques and ornaments

The emergence of new Chinese style is not only a revival and development of traditional Chinese design, but also a way to promote and convey the five-thousand-year-old Chinese history and culture. For instance, antique wooden furniture, traditional Chinese calligraphy and painting works, blue and white porcelain ornaments, antique pendants, etc. (Figure 2). All these collectively embody the profound historical and

cultural heritage of China and the traditional classical style and artistic conception of China. They not only contain the modern people's original yearning for life and spirit, but also reflect their longing for life's mood and spiritual pursuit. Moreover, they are the inheritance and promotion of the thousand-year-old cultural connotation and traditions of China.

### 2.2. Reasonable Layout of Space

New Chinese style inherits and carries forward the spatial layout of traditional Chinese style in interior design. On this basis, it pays more attention to the sense of layering in space. Besides reasonable allocation and layout in space design, it also actively uses decorative materials such as screens and partitions to express it. At the same time, in practical application, new Chinese style also takes into account the different functions of space. Through design techniques, a unified multi-element artistic expression and aesthetic are presented, creating a clearly layered spatial layout.

Compared with traditional Chinese style, new Chinese style often uses screens or window lattices, Chinese wooden doors, and craft partitions when visual obstruction is needed. It mainly features simple shapes and incorporates Chinese elements, thereby making the space more layered and three-dimensional. It is also paired with new Chinese furniture to highlight the artistic sense and the traditional cultural atmosphere of the entire space.

### 2.3. The Integrity of Lines

The Overall Grasp of Lines in Interior design by the new Chinese style is also quite standardized. It combines the rigor of traditional Chinese style with the grandeur of modern simplicity. Traditional patterns, symbols, characters, etc. complement the furniture perfectly under the outlining of lines. The materials and styles of the lines are more diverse than those of traditional Chinese lines, and they are also organically integrated with decorative techniques, allowing them to be fully utilized in the spatial layout. The lines are often mainly sharp and simple straight lines, combined with modern minimalist style furniture, to reflect the fast-paced life attitude of modern people.

### 2.4. Color Matching

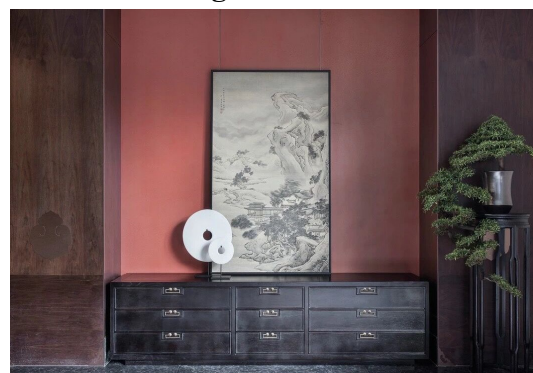

Figure 3. Black cabinet, Chinese red wall and original wood (rich texture and grain)

The color matching of new Chinese style in interior design has undergone a revolutionary change compared to traditional Chinese style. This is not due to its own development demands, but because with the development of The Times and the change of concepts, people's preferences, tolerance and attempts at colors have had a new impact. It is no longer the

single color system of traditional Chinese style in the past, but mainly black, white and gray. Red, yellow and blue, as auxiliary colors, not only meet people's emotional needs and personality shaping, but also open up a brand-new perspective on color matching in interior design.

### 2.5. Practical Functionality

New Chinese style not only integrates diversity in style but also closely combines ergonomics (Figure 4). When designing, more emphasis is placed on lines and structures, which enhances the practical functions of furniture. This is also the reason why many people choose the new Chinese style. In contrast to traditional Chinese furniture, although it has obvious cultural elements in its design, it fails to make good use of ergonomics, thus failing to play its due role and function.

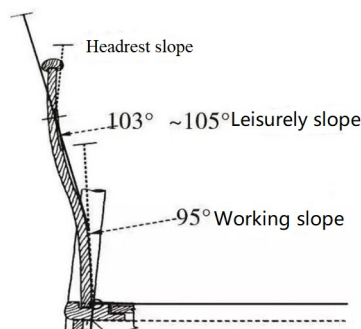
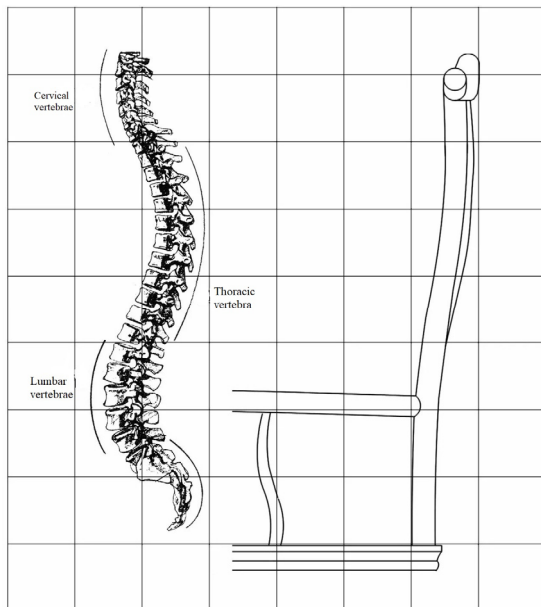

Figure 4. Ergonomics (the tube cap chair mentioned earlier)

## 3. Application Approaches of New Chinese Style in Interior Design

As one of the most popular styles in interior design nowadays, the expression and application of new Chinese style can be described as rich and colorful, vivid and lifelike. Here, it mainly refers to the soft furnishing part of new Chinese style in interior design, because interior soft furnishing has become the benchmark of interior design in decoration. It not only enables people to obtain a direct sense of perception, but also deeply represents the meaning of soft furnishing.

### 3.1. New Chinese-style Furniture Design

Furniture design can immediately reflect the style of interior design. Therefore, the furniture design of the new Chinese style not only retains the classical temperament of traditional Chinese furniture but also integrates postmodern design techniques. On the basis of inheritance and development, it reconstructs a kind of furniture design with Chinese national characteristic symbols. The emergence of this design has brought revolutionary changes and impacts to the entire Chinese interior design, making it more casual and flexible in interior design. For instance, in the design of new Chinese-style furniture, not only are the lines smooth, the shapes exquisite and the functions practical, but also the dullness and stiffness of traditional Chinese furniture are avoided. The common approach in new Chinese-style design is to combine ancient materials with modern soft furnishings, making full use of both ancient and modern materials to create new shapes. These novel designs bring people a strong visual impact and a refreshing feeling. [1]

### 3.2. New Chinese-style Fabric Design

Fabric has always been an indispensable and important element in home decoration from ancient times to the present. This is not only because of the diversity of fabric materials and the variability of colors, but more importantly, it can be combined with other materials to create design effects suitable for different styles. Therefore, fabric design also plays a crucial role in the new Chinese style. For instance, in the new Chinese style, curtains, sofas, tablecloths, wall fabrics, throw pillows, etc. (see Figure 5) all adopt fabric designs. Different from other design styles, the new Chinese style not only emphasizes the mixing and matching of fabric materials and colors, but also pays attention to the overall unity of the interior design style, that is, the unity of the interior design style, color and fabric materials and colors. In the selection of fabric materials, The new Chinese style mainly features traditional cultural patterns and embroidery on cotton, linen and yarn, and integrates metallic elements from the postmodern design style. When it comes to the color selection of fabrics, the new Chinese style mostly uses black, white and grey as the main colors, and integrates them with the visual effect of contrasting colors. This can not only attract people's attention, but also maximize the rationality of the application of new Chinese-style fabrics.

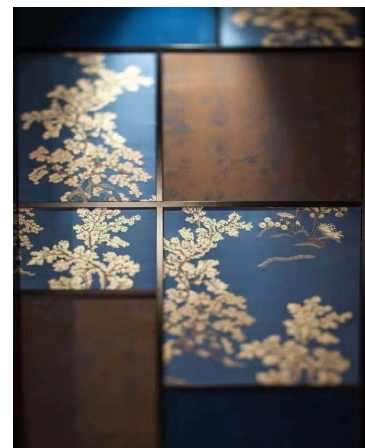

Figure 5. New Chinese-style fabric design (embroidery)

### 3.3. New Chinese-style Lighting Design

The application of lighting design in the new Chinese style

mainly focuses on antique-style lamps. Of course, when designing and choosing lamps, the furniture design and fabric design of the new Chinese style are also referred to. Compared with traditional Chinese-style lamps, new Chinese-style lamps can choose not only antique-style lamps but also fashionable designs that keep up with The Times. In terms of the design of lamps, new Chinese-style lamps can be classified into single type, combined type and mixed type. Single type lamps are mostly used for table lamps, wall lamps, ceiling lamps and floor lamps. Combined type lamps are used for living room lamps, bedroom lamps, corridor lamps, etc. Mixed type lamps are mostly used in commercial new Chinese-style stores, storefronts and studios. In terms of the materials of the lamps, there are leather and fabric ones, metal frame ones, crystal chandeliers and hybrid material lamps, etc. Lamps of different materials can be applied to different spatial layouts. Of course, contemporary new Chinese-style lamps, apart from their own lighting function, mainly serve to echo or decorate the furniture and space.

### 3.4. Design of new Chinese-style Decorative Items



Figure 6. New Chinese-style decorations

Although the role and function of decorative items in interior design are not extremely crucial, they play an important role in embellishment and enhancement in new Chinese-style design. Because the main form of expression of the new Chinese style is to metaphorically represent or represent traditional Chinese culture, and the decorative items and arrangements of the new Chinese style precisely achieve this. New Chinese-style decorative items, as decorative items, have their own considerations. For instance, during the display process, there is a distinction between primary and secondary elements, and the color, material, and volume of the displayed items need to be reasonably arranged and utilized [2] (see Figure 6). The purpose of doing this is that it avoids the disorder in space and highlights the sense of layering in the space more. The design of new Chinese-style decorative items needs to take into account the overall design style. Flat decorations mainly include framing and hanging pieces, calligraphy works and art paintings, etc. Three-dimensional decorative items include blue and white porcelain, window decorations and lanterns, etc. [3]. In addition, there are also antique items, flowers and plants, stone vessels and other decorative items. The number of them in new Chinese-style design does not need to be too large, but

each has its own use. It can significantly enhance the Chinese texture of interior design. Different styles of decorative items, while highlighting the uniqueness of the new Chinese design style, need to create a harmonious and unified spatial atmosphere even more.

### 3.5. New Chinese-style Greening Design

In ancient China, people often composed poems and painted in their courtyards. From small bonsai to large gardens, they have always revealed people's love for nature and the ancient concept of harmony between man and nature. New Chinese-style greening often uses bonsai, potted plants, and flower arrangements to enhance the indoor atmosphere. Common materials such as plants, flowing water, soil, and rockeries are used to create small scenes in the POTS, like a miniature of nature. It plays a crucial role in the formation of the indoor atmosphere. When designing, it fully considers the living habits of modern people and adopts the new Chinese-style design method to fill the indoor space with the breath of nature. In traditional Chinese culture, plum blossoms, orchids, bamboo and chrysanthemums are regarded as the four gentlemen of flowers, which express the refined interests and noble virtues of ancient scholars. Their application in interior design is also becoming increasingly diverse. Extracting elements based on their different characteristics and applying them to the new Chinese style can soften the space.

## 4. Application Directions of New Chinese Style in Interior Design

### 4.1. The Application of New Chinese Style in Dining Spaces

Chinese culinary culture is unique in the world. With a history of five thousand years, China has diverse culinary cultures, and naturally, there are also differences in interior design. Many of the new Chinese-style dining Spaces that showcase historical culture continue the style of the Tang Dynasty, while some also reflect the local folk customs. The new Chinese-style dining space can also convey a festive atmosphere. In China, banquets and feasts are traditional forms of social interaction. From sacrificial activities to today's national diplomacy, wedding and birthday banquets, and gatherings of relatives and friends, dining Spaces are indispensable. Some restaurants also have a strong rural theme, mainly characterized by simplicity and nature, making diners feel as if they were in nature. Modern people's dietary concepts have shifted from merely satisfying hunger to enjoying refinement, which is a manifestation of people enjoying life after work.

### 4.2. The Application of New Chinese style in Hotel Design

The design of new Chinese-style hotels is mainly reflected in the complementarity between the lobby design and the space, the depth of the corridor design, the comfort level of the guest room design and the atmosphere of the restaurant design. The color selection of new Chinese-style hotels should be in line with the overall atmosphere of the hotel. In terms of color usage, large areas of decorative colors should not be used, otherwise it will give people a sense of oppression. Color blocks are mostly used. Enhance the impact of colors in the layout, contrast colors with the space, and strengthen the expressiveness of colors.

### 4.3. The application of New Chinese Style in the Exhibition Space

The application of new Chinese style in the exhibition space is mainly manifested in the spatial layout, decorative colors and the use of traditional symbols. Spatial layout is widely applied in traditional Chinese architectural culture, mainly manifested in the centralized and symmetrical layout of traditional tubular buildings. Chinese traditional culture emphasizes "ritual system", "order", etc. Therefore, spatial layout should integrate functions and sequences into it. The design in terms of decoration and color should be simple and elegant, with local accents of color to create an artistic conception and showcase the refined atmosphere of the new Chinese style. Traditional symbols also express the artistic conception of architectural space design and are indispensable in exhibition Spaces. They often reflect the architectural concepts, intentions and ideas.

## 5. The Development Trend of New Chinese Style in Interior Design

With the continuous development of the new Chinese style in interior design, designers are paying more attention to the application and development of the new Chinese style, especially how to showcase Chinese traditional culture in the furniture design, fabric design, lighting design, decorative decoration design and greening design of the new Chinese style. This is worthy of further thinking and exploration by designers. Because the new Chinese style is not merely a replication of traditional culture as people usually understand it. Instead, it perfectly integrates and matches the essence of modern decoration and traditional culture to meet the aesthetic standards of modern people and add a brand-new cultural charm to interior design. For instance, designers use the materials and patterns of the new Chinese style to represent them with modern design language. Through the methods of refinement, simplification and recombination, they carry out innovation and creation, enabling the new Chinese design style to express the spirit and aspiration of users for classical culture.

The new Chinese style can be regarded as a "dark horse" in interior design. Its emergence has overturned the entire interior design market and stood out as a refreshing stream in the mixed decoration design styles. This is not only attributed to the inheritance and continuation of China's five-thousand-

year-old history and culture, but also to the innovation and development of Chinese interior design. In the development of interior design, the emergence of the new Chinese style is not accidental but rather an expression of traditional Chinese culture throughout the entire historical process. In short, the new Chinese style uses modern design language to represent China's native culture, which precisely aligns with people's sense of identity, their attachment to traditional culture, and modern design.

In addition, the new Chinese style also reflects the value pursuit of traditional culture and the need for diversified cultures. By integrating traditional culture into modern interior design, it enables more young people to directly experience the essence and connotation of Chinese traditional culture. Meanwhile, promoting the new Chinese style is an effective way to inherit and continue traditional Chinese culture [4]. Different types of new Chinese-style design works contain different traditional cultures and reflect the significant importance of traditional culture in people's life and practical activities.

The new Chinese style has a thousand-year-old cultural and historical accumulation. The development of this style will eventually be combined with modern concepts, possessing strong adaptability and integration to The Times. In the future, it is bound to occupy a broad audience and development platform. Its future development trend not only attracts the attention of many local designers but is also bound to show a brilliant style in the history of world design [5].

## References

- [1] Zhao Xiaoli Analysis of Interior Soft Decoration Design and Application of New Chinese Style [J]. *Art Research*, 2018 (01): 208-209.
- [2] Ma Steel. Characteristics and Development Trends of New Chinese Style [J]. *China Building Materials Technology*, 2015 (12): 100-101.
- [3] Zheng Yuming. The Application of New Chinese Style in Modern Hotel Design [J]. *Architectural Economy*, 2021, 42 (04): 137-138.
- [4] Liu Yibin. Interior Design of New Chinese Style [J]. *Architectural Structure*, 2020,50(23):150.
- [5] Jiang Yan. New Chinese style style of interior design [J]. *Journal of Shanghai textile science and technology*, 2018, 46-48 (10): 88. DOI: 10.16549/j.carol carroll nki. Issn 1001-2044. 2018. 10.046.