

# Based on STM32 SCM Intelligent Greenhouse

Minhua Ju

Suzhou Vocational Institute of Industrial Technology, Suzhou 215104, China

---

**Abstract:** With the continuous growth of the global population and the continuous development of agricultural production, there are many problems in the traditional agricultural production mode, such as resource waste, low production efficiency, environmental pollution, and the urgent need for innovative solutions to meet the growing food demand and sustainable development goals. This paper introduces an intelligent greenhouse system based on STM 32 single-chip microcomputer, using advanced technology and automation functions, in improving the efficiency, quality and sustainability of agricultural production. The hardware composition of the intelligent greenhouse system includes STM 32 MCU, various sensor actuators, ESP8266 module and user interface module.

**Keywords:** STM32; ESP8266 WIFI module; Smart cloud platform.

---

## 1. Introduction

With the continuous growth of the global population and the continuous development of agricultural production, how to improve the quality and quantity of crop production has become an important challenge.

Traditional agricultural production methods have many problems, such as resource waste, low production efficiency, environmental pollution, and innovative solutions to meet the growing food demand and sustainable development goals. In this context, the intelligent greenhouse system based on STM 32 MCU emerged at the historic moment, bringing revolutionary.

### 1.1. System design ideas

With the continuous development of the society and people's increasingly high requirements for the quality and efficiency of agricultural production, intelligent agricultural technology arises at the historic moment. The intelligent greenhouse system based on STM 32 SCM is a potential solution that can improve the quality and quantity of crop production and realize intelligent monitoring and control. The following is an analysis of the system architecture, hardware composition, sensor selection, and control strategy.

#### 1.1.1. System architecture

Design an intelligent greenhouse system requires considering multiple aspects of functions and components, so the design of the system architecture is a crucial step. Our smart greenhouse system adopts a hierarchical architecture, including the following levels:

**Sensor layer:** This layer includes a variety of sensors that are used to monitor environmental parameters in the greenhouse, such as temperature, humidity, light, soil humidity, etc. Sensor data is the basis of the system for real-time monitoring and control.

**Control layer:** The control layer includes STM 32 controller, which is responsible for processing the sensor data, executing the control algorithm and communicating with the actuator. The STM 32 MCU is the core controller of the system, responsible for decision-making and execution.

**Execution layer:** the executive layer includes actuators, such as lights, water pumps, fans, etc., which are used to perform the corresponding operations according to the

instructions of the control layer. These actuators adjust the greenhouse environment through the control of STM 32 microcontroller.

**Communication layer:** The communication layer is used to communicate with external cloud services or user interfaces. We chose the ESP8266 module as the wireless communication module to connect with the smart cloud for remote monitoring and control.

**User interface layer:** The user interface layer includes human-machine interface, which can be PC terminal, mobile terminal application or Web interface, used for users to remotely monitor the state of greenhouse, control equipment and view data.

#### 1.1.2. Hardware composition

In terms of the hardware composition of the system, we selected a series of key hardware components to realize various monitoring and control functions:

**STM 32 SU:** As the main controller of the system, STM 32 SU is responsible for collecting sensor data, running control algorithm, controlling actuator, and processing communication tasks.

**Sensor:** the system uses various kinds of sensors, such as DHT 11, FC-28 soil moisture detection module, 0.96-inch OLED display, buzzer, photoresistor, etc., to obtain the data of various environmental parameters in the greenhouse.

**Actuator:** The actuator includes LED lights, water pumps, fans, etc., which is used to adjust the environmental conditions in the greenhouse, such as lighting, irrigation and ventilation.

**ESP8266 module:** The ESP8266 module is responsible for communicating with the intelligent cloud, realizing the remote monitoring and control functions, and connecting to the LAN and the Internet at the same time.

#### 1.1.3. Control strategy

The control strategy of the system is the core part of the system design. We will adopt a feedback control strategy based on sensor data to automatically adjust the status of the actuator according to different environmental parameters. For example, when the temperature is too high, the system can start fans for cooling; when the soil moisture is too low, the system can start water pumps for irrigation. In addition, we will also implement the remote control function, allowing users to remotely monitor and control the greenhouse

environment through the cloud service or the user interface, to adapt to different needs.

## 1.2. Hardware Block Diagram

Based on the STM 32 CM design, the hardware part uses photosensitive resistance, DHT 11 soil humidity sensor, ESP8266, OLED display module, fan and LED lights and other hardware. Here are some of the main hardware features: DHT 11: used for measuring temperature and humidity, suitable for environmental monitoring. FC-28 soil moisture detection module: used to measure soil moisture and realize intelligent irrigation control. 0.96-inch OLED display: used to display real-time data and system status information. Buzzer: used to issue alarms and reminders. Photoresistor: used to monitor the light conditions, to achieve lighting control and plant growth management. ESP8266: used to establish a connection with the intelligent cloud platform, so as to realize data communication.

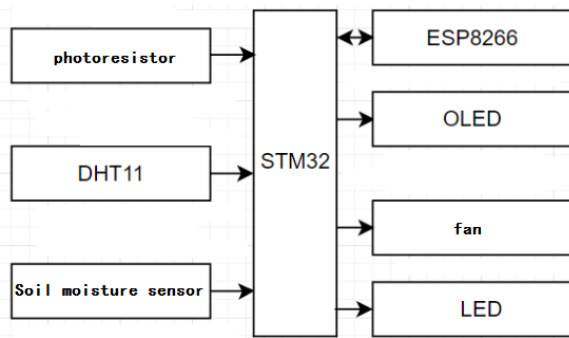

Figure 1. Hardware block diagram

## 2. Hardware circuit design

### 2.1. STM32 MCU

This design uses STM32F103C8T6 single chip computer as the core of the system. STM32F103C8T6 Is a microcontroller based on ARM Cortex-M3 kernel, widely used in a variety of embedded systems, including intelligent greenhouse control system. Temperature and humidity detection circuit.

### 2.2. The OLED display circuit

The display part of this design system uses the OLED display module to realize the data display. The OLED display screen is a small, high-resolution display device that is widely used in embedded systems. The OLED display screen is the key output equipment of the smart greenhouse system, which is used to display the environmental data, system status and user interface.

### 2.3. Soil moisture detection circuit

The FC-28 soil moisture detection module is a sensor module for measuring soil moisture, which is widely used in intelligent greenhouse systems. The smart greenhouse design also used the sensor to detect the soil moisture in the greenhouse.

### 2.4. Keynote circuit

This system uses independent keys to realize human-computer interaction. The button has two pins, the button is a physical structure, and the internal shrapnel button passes when it is pressed. This design uses three keys, as shown in Figure Figure 2.

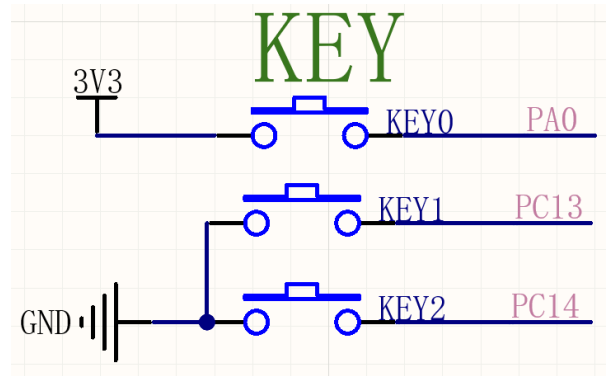

Figure 2. Key circuit diagram

There are three trigger modes: single click, double click, and long press.

### 2.5. Buzzer circuit design

A buzzer is a common sound generator used to generate a sound or alarm in an embedded system. The buzzer is used in the intelligent greenhouse system to alert, alert or indicate the system status.

wireless communication line

As one of the key components of the intelligent greenhouse system, the ESP8266 module is responsible for realizing the connection and communication with the smart cloud. Smart Cloud is a company that provides cloud services for the Internet of Things. Through its cloud platform, we can realize the remote monitoring, data storage and remote control of the intelligent greenhouse system.

### 2.6. Light detection circuit

A resistor, also known as a resistor or resistor, is a sensor that can change the resistance value according to the change of light intensity. In the smart greenhouse system, the sensor is used to monitor light conditions and help achieve functions such as light control, plant growth regulation and energy management.

### 2.7. Schematic of the system

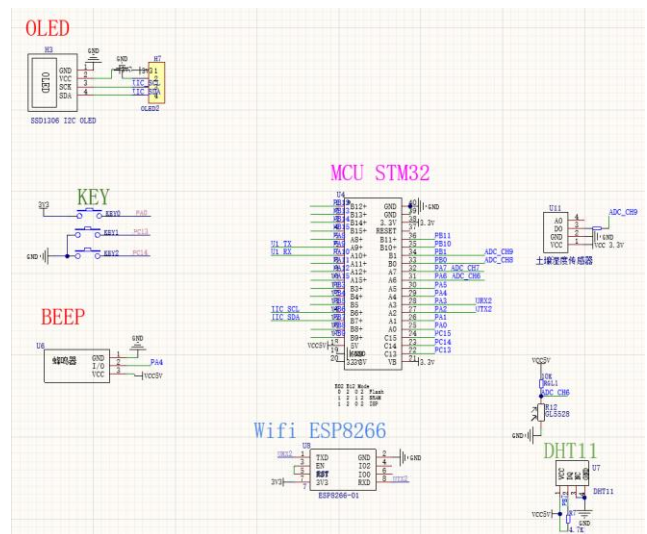

Figure 3. System schematic

## 3. Software design

### 3.1. Master program design

The main program of the intelligent greenhouse system is

the core of the whole system, which is responsible for the core functions such as data acquisition, executor control, communication and user interaction. The design of the main program is based on an event-driven architecture with multithreading and interrupt processing to achieve high efficiency and real-time performance of the system. 1. Data acquisition thread: The thread regularly reads the data from the sensor module, including temperature, humidity, soil humidity, light, etc., and stores the data in memory for subsequent processing. 2. Control algorithm thread: The control algorithm thread is responsible for generating control instructions, according to the sensor data and preset control strategies, such as controlling the light brightness and water pump operation time, etc. 3. Actuator control thread: The actuator control thread receives instructions from the control algorithm thread, and is responsible for controlling the operation of the actuator, opening or closing the equipment, and adjusting the parameters. 4. Communication thread: The communication thread is responsible for communicating with the ESP8266 module, uploading the sensor data to the cloud, receiving the control instructions from the cloud, and communicating with the user interface module. 5. User interface thread: User interface thread is responsible for processing the interaction of the user interface, receiving user instructions, displaying real-time data, and transmitting user operations to other threads.

### 3.2. Wit cloud platform configuration

In this design, the smart cloud will be used as the cloud platform of the system to realize the remote monitoring and control of the environmental data in the greenhouse. By connecting the device to the cloud platform, you can get rid of the distance limit. As long as the device is kept connected to the network, you can remotely view the data in the greenhouse and control the actuator. To connect the device to the smart cloud, you need to complete the corresponding configuration. The following is a flow chart of the device's access to the smart cloud.

## 4. Hardware debug

### 4.1. Display debugging

After the smart greenhouse is connected to the power supply, the system will automatically run, first connecting to the WIFI and displaying the current data of the system through OLED. The display screen shows the buzzer state, system mode, light intensity data and threshold switch state, temperature and humidity data and light intensity state respectively.

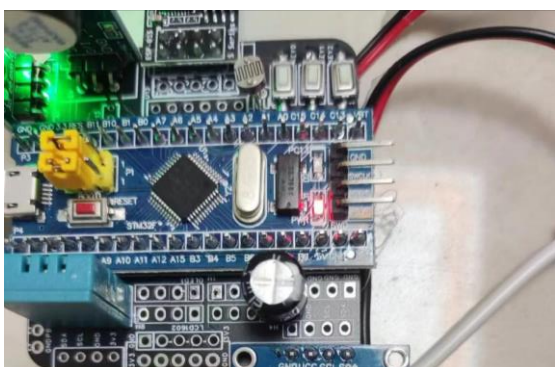

Figure 4. Shows the functional debugging

### 4.2. Cloud platform debugging

When the system runs for the first time, it needs to input the WIFI password in the Smart cloud APP to pair it, and then it can be run directly. After the system is powered up, the operation interface of the system can be entered through the APP. In the interface, you can control the operation of the system such as lights, pumps, fans and threshold data, and also see the current environmental data of the system.

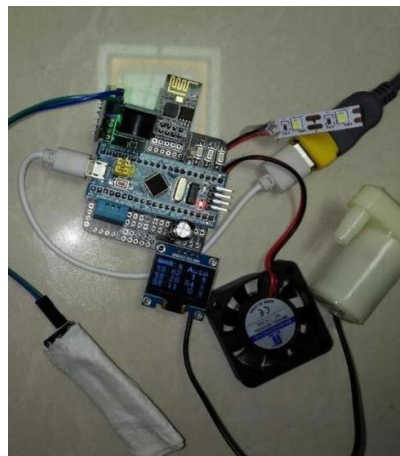

Figure 5. APP data transmission and debugging

## 5. Research conclusion

In this paper, the existing problems of traditional agricultural production methods, including resource waste, unstable production quality, labor shortage, environmental pollution and food security challenges, are introduced. These problems restrict the sustainability and development prospects of traditional agriculture, and new solutions are urgently needed to improve the efficiency and quality of agricultural production. This paper also introduces the hardware composition of the intelligent greenhouse system, including STM 32 MCU, various sensors, actuators, ESP8266 module, and user interface module. These hardware components form the basis of the system for critical tasks such as data acquisition, environmental control, remote communication, and user interaction. Through experiments and tests, the performance and effect of the intelligent greenhouse system are verified. The experimental results show that the system can monitor environmental parameters in real time, realize intelligent control, improve production efficiency, reduce resource waste, reduce labor demand, and enhance food security.

## References

- [1] Jian W U, Hou W, Zheng B. A Temperature Control System Based on STM32F103[J]. Computer Knowledge & Technology, 2022.
- [2] Yang Y. Intelligent transmission system based on TC35i[J]. Electronic Test, 2021.
- [3] Liu Hailan. On the Problems and Countermeasures of Curriculum Design in Higher Education [J], Journal of Lingling University, 2020, (10).
- [4] Zhang Yaoxue. Proceedings of the National Experience Exchange Conference on the Integration of Industry, Education, and Research in Higher Vocational and Technical Education (C), Higher Education Press, 2023.